

Port of Kennewick
Benton County, Washington

East 3rd Storage Building Select Demolition

Contract Documents and Specifications

August 30, 2024



PORT OF KENNEWICK
350 Clover Island Drive, Suite 200
Kennewick, Washington 99336
(509) 586-1186

TABLE OF CONTENTS

VOLUME I

PROCUREMENT AND CONTRACTING REQUIREMENTS

001130	Invitation for Bids
002113	Instruction to Bidders
003101	Permit Application
003103	Cultural Resource Protection
004110	Bid Form
004113	Sub-Contractor List
004115	Anti-Discrimination Certificate
004117	Non-Collusion and Debarment Affidavit
004119	Wage Laws Compliance Affidavit
005000	Public Works Contract
007000	Public Works Contract General Conditions

VOLUME II

CKJT PLAN SET (8-Sheets)

SECTION 001130 - INVITATION FOR BIDS

The Port of Kennewick (Owner) will receive sealed bids for the East 3rd Storage Building Select Demolition until **2:00 p.m. (PDT) Tuesday, October 1, 2024** in the Port of Kennewick Commission Chambers, 350 Clover Island Drive, Suite 200, Kennewick, Washington. Bids received after the stated time will not be accepted. Bid proposals must be in a sealed envelope, which shall be clearly marked “East 3rd Storage Building Select Demolition” and show the name and address of the bidder (Bidder). The bids will be publicly opened by Port of Kennewick staff and read aloud at 2:00 p.m. Interested parties are invited to attend. Official bid results shall be made public within 72 hours of bid opening. Contract will be awarded to the lowest responsive bidder. The Owner reserves the right to reject any or all bids or to waive informalities in the bidding. No bids shall be withdrawn for a period of 30 days subsequent to opening of bids without the written consent of the Owner. The Owner shall award the work to the lowest, responsive Bidder whom the Owner believes best serves its interest. The Port may not award the work to any Bidder, if the Port believes that best serves its interest.

The project will repair a fire damaged building by removing the damaged areas and leaving areas to remain for storage use. Of the existing 12,000sqft Warehouse building and 1,223sqft office area, 7,200sqft of the warehouse and all of the office are to be removed. The south wall of the remaining 4,800sqft building to remain will be treated with exterior weatherproof improvements and the remaining slab area will be fenced with gates and exterior security lighting will be added.

A Pre-Bid Conference, for all General Contractor prospective bidders, will be held **Tuesday, September 17th, 2024, 10:00 a.m.** at 1328 E. 3rd Avenue Kennewick, Washington. This conference is non-mandatory but recommended for both prime bidders and sub-contractors.

Preliminary estimated construction: \$180,000 excluding sales tax

Contract documents may be examined at the following locations after 10:00 a.m., Tuesday September 3, 2024:

Tri City Construction Council
20 East Kennewick Avenue
Kennewick, WA 99336
(509) 582-7424

Contract documents will be available for review and download on or after **Sunday, September 1, 2024**, at the following link: www.portofkennewick.org/contracting/#bid.

Each bid shall be accompanied by a certified check, cashier's check, bank draft, or money order payable to the Port of Kennewick or a bid bond with a corporate surety licensed to do business in the State of Washington, in an amount not less than five (5%) percent of the amount of the base bid, including sales tax. Should the successful Bidder fail to enter into such contract and furnish satisfactory performance bond or quality assurance submittals within the time stated in the contract documents, the bid proposal deposit shall be forfeited to the Port of Kennewick. Each Bidder shall be required to submit signed and notarized i) Non-Collusion and Debarment Affidavit, ii) Anti-Discrimination Certificate, iii) Wage Laws Compliance Affidavit, iv) List of Subcontractors and v) Letter of Qualifications.

Larry Peterson, Director Planning & Development
Port of Kennewick

END OF SECTION 001130

SECTION 002113 - INSTRUCTIONS TO BIDDERS

ARTICLE 1 – DEFINED TERMS	3
ARTICLE 2 – COPIES OF BIDDING DOCUMENTS	3
ARTICLE 3 – EXAMINATION OF BIDDING DOCUMENTS, CONTRACT DOCUMENTS AND REGULATIONS	3
ARTICLE 4 – PRE-BID CONFERENCE	3
ARTICLE 5 – PROJECT SITE AND OTHER AREAS	4
ARTICLE 6 – INTERPRETATIONS AND ADDENDA	4
ARTICLE 7 – BID GUARANTEE	5
ARTICLE 8 – CONTRACT TIMES	5
ARTICLE 9 – LIQUIDATED DAMAGES	5
ARTICLE 10 – SUBSTITUTE AND “OR-EQUAL” ITEMS	5
ARTICLE 11 – SUBCONTRACTORS, SUPPLIERS AND OTHERS	6
ARTICLE 12 – PREPARATION OF BID – BID FORM	6
ARTICLE 13 – BID PRICE	7
ARTICLE 14 – TAXES	7
ARTICLE 15 – BIDDER’S NAME AND SIGNATURE	7
ARTICLE 16 – SUBMISSIONS OF BID	8
ARTICLE 17 – MODIFICATION OF BID	8
ARTICLE 18 – OPENING OF BIDS	8
ARTICLE 19 – BID VALIDITY	8
ARTICLE 20 – EVALUATION OF BIDS – EVALUATION STANDARD	8
ARTICLE 21 – VERIFICATION OF BID PRICES	9
ARTICLE 22 – CLAIM OF ERROR	9
ARTICLE 23 – RESPONSIVE BIDS	9
ARTICLE 24 – BIDDER QUALIFICATIONS	9
ARTICLE 25 – SUPPLEMENTAL BIDDER RESPONSIBILITY CRITERIA	10
ARTICLE 26 – COLLUSION	11
ARTICLE 27 – RETURN OF BID GUARANTY	12
ARTICLE 28 – SINGLE BID RECEIVED	12
ARTICLE 29 – RIGHTS OF THE OWNER	12
ARTICLE 30 – AWARD OF CONTRACT – NOTICE OF AWARD	12
ARTICLE 31 – PERFORMANCE AND PAYMENT BONDS	12

Port of Kennewick East 3 rd Storage Building Select Demolition	August 2024
ARTICLE 32 – EXTENSION OF TIME	13
ARTICLE 33 – FAILURE TO EXECUTE CONTRACT	13
ARTICLE 34 – CANCELLATION OF AWARD	13
ARTICLE 35 – WAGE RATE DETERMINATION	13
ARTICLE 36 – RETAINAGE	14

PART 1 ARTICLE 1 – DEFINED TERMS

- 1.1 Terms used in these Instructions to s, which are defined in the Standard General Conditions of the Construction Contract, have the meanings assigned to them in the General Conditions. The term "successful Bidder" means the lowest, qualified, responsible Bidder to whom Owner (on the basis of Owner's evaluation as hereinafter provided) makes an award. The Architect/Engineer of record, shall be hereinafter termed the A/E.

PART 2 ARTICLE 2 - COPIES OF BIDDING DOCUMENTS

- 2.1 Complete sets of the Bidding Documents available for view and download on or after Sunday, September 1, 2024, at: www.portofkennewick.org/contracting/#bid
- 2.2 Complete sets of Bidding Documents shall be used in preparing Bids; neither the Owner nor the A/E assume any responsibility for errors or misinterpretations resulting from the use of incomplete sets of Bidding Documents.
- 2.3 The Owner and the A/E, in making copies of Bidding Documents available on the above terms, do so only for the purpose of obtaining Bids on the Work and do not confer a license or grant for any other use.

PART 3 ARTICLE 3 - EXAMINATION OF BIDDING DOCUMENTS, CONTRACT DOCUMENTS AND REGULATIONS

- 3.1 The Bidder shall examine the Contract Documents and any other data made available to the Bidder relating to the Work, and shall comply with all instructions and provisions. The Bidder shall promptly notify the Owner of ambiguities, inconsistencies, or errors, if any, which it may discover upon examination of the Contract Documents and any other data made available to the Bidder relating to the Work. The submission of a Bid shall constitute an acknowledgement upon which the Owner may rely that the Bidder has thoroughly examined and is familiar with the Contract Documents and has reviewed all applicable federal, state and local statutes, regulations, ordinances and environmental documents relating to the work and all permits which have been applied for and/or issued pertaining to the Work. The failure or neglect of a Bidder to examine any of the Contract Documents, statutes, regulations, ordinances, environmental documents or permits shall not relieve the Bidder from any obligations with respect to the Contract Documents or the Work.
- 3.2 The Bidder shall verify that all documents provided by the Owner, and upon which the Bidder is basing its Bid, are full and complete with no missing pages, sheets or unintentional blank spaces. Submittal of a Bid indicates the Bidder has verified it has obtained all Owner-supplied Contract Documents. No claim for additional work due to missing Bid information will be considered.
- 3.3 If the Bidder elects to review or download Contract Documents electronically from websites it is the Bidder's responsibility to ensure that all documents are complete and that all addenda have been reviewed prior to submission of Bid.

PART 4 ARTICLE 4 - PRE-BID CONFERENCE

- 4.1 A Pre-Bid conference, if held, will be as stated in the advertisement or Invitation To Bid.

Representatives of Owner and/or A/E will be present to discuss the Project. Owner will transmit to all prospective Bidders of record such Addenda as A/E considers necessary in response to questions arising at the conference. Oral statements may not be relied upon and will not be binding or legally effective.

PART 5 ARTICLE 5 – PROJECT SITE AND OTHER AREAS

- 5.1 The Project Site is identified in the Bidding Documents. Easements for permanent structures or permanent changes in existing facilities are to be obtained and paid for by Owner unless otherwise provided in the Bidding Documents. All additional lands and access thereto required for temporary construction facilities, construction equipment, or storage of materials and equipment to be incorporated in the Work are to be obtained and paid for by Contractor.
- 5.2 Project excavation at site involves an additional level of observation and monitoring for the potential discovery of cultural resources. The Owner has a direct contract with the Confederated Tribes of the Umatilla Indian Reservation (CTUIR) for observation services. **Contractor MUST coordinate with Owner and CTUIR representative(s) prior to any site excavation during the term of Project.**
- 5.3 Bidder shall inspect and compare the work site and Contract Documents to evaluate the location of the Work, the actual physical conditions of the site, and surface and subsurface conditions ordinarily encountered and generally recognized as inherent in the Work. Bidder shall obtain written permission from the Owner prior to entering the work site or conducting physical testing of the work site, except for attendance during a scheduled prebid examination.
- 5.4 If the Bidder finds facts or conditions which appear to conflict with the Contract Documents or with any other data made available to the Bidder relating to the Work, the Bidder shall promptly notify the Owner in writing.

PART 6 ARTICLE 6 - INTERPRETATIONS AND ADDENDA

- 6.1 Requests for interpretation or reports of ambiguities shall be made in writing and delivered to the Owner at least seven (7) calendar days before the Bid submittal deadline. Clarifications, interpretations, or supplemental instructions which change the scope of work and or schedule described in the contract documents, will be issued only in the form of written addenda. All addenda shall become part of the Contract Documents and any subsequently awarded Contract.
- 6.2 Copies of addenda will be mailed, delivered, faxed, or electronically transmitted to all plan holders of record at the respective address furnished for such purposes.
- 6.3 Each Bidder shall acknowledge the receipt of all addenda issued on its Bid. If such acknowledgement is not made, the Owner reserves the right to show constructive notice through delivery records or the Bidder's use of information contained in the addenda.
- 6.4 Bidders shall not rely upon any oral statements or conversations, whether at the pre-bid conference or otherwise, that they may have with Owner employees, agents or representatives regarding the Contract Documents. No oral clarification or interpretations

will be made to any Bidder as to the meaning of the Contract Documents.

PART 7 ARTICLE 7 - BID GUARANTEE

- 7.1 The Bid shall be accompanied by a Bid Guarantee in an amount at least 5% of the total contract sum.
- 7.2 The Bid Guarantee shall be in one of the following forms and made payable to the Owner: a Bid bond, either the form provided, or a form acceptable to the Owner which contains provisions substantially similar to those provided, duly completed by a guarantee company authorized to do business in the state of Washington; a U.S. postal money order; or a certified check or cashier's check drawn upon a banking institution. The surety signing the bid bond must appear on the U.S. treasury department's most current list (circular 570 as amended), and the surety's name must appear in the current authorized insurance company list in the state of Washington published by the office of the insurance commissioner. Attorneys-in-fact who sign Bid bonds must file with each bond a certified and effectively dated copy of their power of attorney
- 7.3 The Bid Guarantee of the successful Bidder will be retained until such Bidder has executed the Contract Agreement and furnished the required Contract Security, whereupon it will be returned; if the successful Bidder fails to execute and deliver the Agreement and furnish the required Contract Security within six (6) days of the Notice of Award, the Owner may annul the Notice of Award and the Bid Guarantee of that Bidder will be forfeited. The Bid Guarantee of any Bidders whom the Owner believes to have a reasonable chance of receiving the award may be retained by the Owner until the earlier of the seventh (7th) day after the "effective date of the Contract Agreement" (term is defined in the General Conditions) or the thirty first (31st) day after the Bid opening. Bid Guarantee of other Bidders will be returned within seven (7) days of the Bid opening.

PART 8 ARTICLE 8 - CONTRACT TIMES

- 8.1 The number of days within which, or the date by which the Work is to be completed, is set forth in the Contract Agreement.

PART 9 ARTICLE 9 - LIQUIDATED DAMAGES

- 9.1 Provisions for liquidated damages, if any, are set forth in the Contract Documents.

PART 10 ARTICLE 10 - SUBSTITUTE AND "OR-EQUAL" ITEMS

- 10.1 Products, equipment, materials or methods described in the Contract Documents are to establish a standard of quality, function, appearance and dimension. A proposed substitution shall have equal attributes in all respects.
- 10.2 During the bidding period written requests by prime Bidders for substitutions may be considered if received by the Owner at least fourteen (14) days prior to the Bid submittal deadline. The Owner may, in its sole discretion, defer the consideration of a proposed substitution until after Contract award.

- 10.3 Each substitution request shall, in accordance with the applicable provisions of paragraph 4.8 of the General Conditions, describe the proposed substitution in its entirety including the name of the material or equipment, drawings, catalog cuts, performance or test data and all other information required for an evaluation. The submittal shall also include a statement noting all changes required in adjoining, dependent or other interrelated work necessitated by the incorporation of the proposed substitution. The Bidder shall bear the burden of proof to show that the proposed substitution meets or exceeds the required function and is equal or superior to the specification.
- 10.4 The Owner may require that samples be submitted or demonstration made prior to approval. The Owner's decision of approval or disapproval of a proposed substitution shall be final.
- 10.5 Approval of substitutions will be made by addenda.

PART 11 ARTICLE 11 - SUBCONTRACTORS, SUPPLIERS AND OTHERS

- 11.1 The Owner encourages and supports the use of M/WBE subcontractors and suppliers on all Work.
- 11.2 In accordance with RCW 39.30.060, when the Work is estimated to cost \$1,000,000 or more, the Bidder shall list on the Bid form the name of each subcontractor to whom the Bidder proposes to directly subcontract heating, ventilation and air conditioning, plumbing as described in chapter 18.106 RCW, and electrical as described in chapter 19.28 RCW, or name itself for the work. The Bidder shall not list more than one subcontractor for each category of work identified unless subcontractors vary with Bid alternates, in which case the Bidder must indicate which subcontractor will be used for which alternate. Failure of the Bidder to list on the Bid form the names of such subcontractors or to name itself to perform such work, or the naming of two or more subcontractors to perform the same work shall render the Bidder's Bid nonresponsive and, therefore, void. The requirement of this section to name the Bidder's proposed heating, ventilation and air conditioning, plumbing, and electrical subcontractors applies only to proposed heating, ventilation and air conditioning, plumbing, and electrical subcontractors who will contract directly with the general contractor submitting the Bid to the public entity. For purposes of this paragraph, a subcontractor is defined as one who contracts directly with the Contractor to furnish materials and labor, or labor only for the performance of the Work.
- 11.3 After Bid opening the Owner may require the apparent low Bidder to identify any proposed subcontractors and major suppliers together with a statement of experience with references for each. Such information shall be submitted within 24 hours of request.

PART 12 ARTICLE 12 – PREPARATION OF BID – BID FORM

- 12.1 The Bid Form is attached hereto.
- 12.2 Bid forms must be completed in ink or typed. The Bid price of each item on the form must be stated in words and numerals; in case of a conflict, words will take precedence. Discrepancies between the indicated sum of any column of figures and the correct sum, thereof, will be resolved in favor of the correct sum.

PART 13 ARTICLE 13 – BID PRICE

- 13.1 All prices on the Bid form shall be in U.S. dollars.
- 13.2 For lump sum Bids the total Contract Sum shall be submitted.
- 13.3 For unit price Bids a price shall be submitted for each item of the Work, an extension thereof, and, if requested, the total Contract Sum.
- 13.4 The price on the Bid form for that element of Work shall include everything necessary for the prosecution and completion of the Work in accordance with the Contract Documents including, but not limited to, furnishing all required materials, equipment, tools, transportation of Owner furnished materials, plant and other facilities and all management, superintendence, labor and services, and field design, except as may be otherwise provided in the Contract Documents.
- 13.5 Estimated quantities, if any, set forth on the Bid form are estimates only, being given only as a basis for the comparison of Bids, and the Owner does not warrant, expressly or by implication, that the actual amount of work will correspond to the estimated quantities. The Owner reserves the right to increase or decrease the amount of any class or portion of the Work and to make changes in the Work as the Owner may deem necessary or appropriate. The basis of payment for unit price Bid items for which estimated quantities were set forth on the Bid form shall be the actual number of unit items provided or performed under this Contract. In the event of a 20% quantity increase or decrease, the unit price may be adjusted as provided in the General Conditions.

PART 14 ARTICLE 14 TAXES

- 14.1 The Work to be performed under this Contract constitutes a "retail sale" as such term is defined in RCW 82.04.050. The prices on the Bid form shall not include state or local retail sales taxes. The Owner will pay state and local retail sales tax on each progress payment and final payment to the Contractor for transmittal by the Contractor to the Washington State Department of Revenue or to the applicable local government. The Contractor will pay retail sales tax on all consumables used during the performance of the work and on all items which are not incorporated into the final work, which tax shall be included in the prices on the Bid form.
- 14.2 No increase will be made in the amount to be paid by the Owner under this Contract because of any misunderstanding by or lack of knowledge of the Contractor as to liability for, or the amount of, any taxes for which the Contractor is liable or responsible by law or under this Contract.
- 14.3 Sales tax shall be shown as a separate item on the Bid form. In any case where it is not included as a separate item, the Owner will add the sales tax to the total of the Bid prices shown.

PART 15 ARTICLE 15 BIDDER'S NAME AND SIGNATURE

- 15.1 The Bid form shall include the legal name and contractor registration number of the Bidder and shall indicate whether Bidder is a sole proprietor, a partnership, a corporation, joint venture, or other legal entity. The Bid form shall be signed by a person legally authorized to bind the Bidder to a contract and shall indicate the Bidder's address. A Bid

form signed by an agent shall have a current power of attorney attached certifying agent's authority to bind the Bidder. Upon request of the Owner the Bidder shall provide corporate or partnership documentation evidencing the Bidder's legal status and showing the authority of the person signing the Bid form to execute contracts on behalf of the Bidder.

- 15.2 The Bid form shall not become a part of the Contract Documents except by inclusion into the Agreement.

PART 16 SUBMISSIONS OF BID

- 16.1 Bids shall be submitted at the time and place indicated in the Invitation to Bid and shall be included in an opaque sealed envelope, marked with the Project title and name and address of the Bidder and accompanied by the Bid Security and other required documents. If the Bid is sent through the mail or other delivery system, the sealed envelope shall be enclosed in a separate envelope with the notation "BID ENCLOSED" on the face thereof.
- 16.2 The List of Subcontractors, Non-Collusive Affidavit, Bid Guarantee, the Certification of Compliance with Wage Payment Statutes and Certification Regarding Lobbying shall be completed, signed, and submitted with the Bid.
- 16.3 No Bid shall be considered which has not been properly submitted online before the Bid submittal deadline specified in the advertisement for Bids. Bidder shall assume full responsibility for any and all potential issues that may arise when submitting its Bid electronically. The Owner encourages all Bidders to complete its Bid submission 2 hours prior to the deadline.
- 16.4 Oral, telephonic, telefaxed, electronic, or telegraphic Bids are invalid and will not receive consideration.

PART 17 ARTICLE 17 - MODIFICATION OF BID

- 17.1 Bids may be modified or withdrawn by an appropriate document duly executed (in the manner that a Bid must be executed) and delivered to the place where Bids are to be submitted at any time prior to the opening of Bids.

PART 18 ARTICLE 18 - OPENING OF BIDS

- 18.1 Unless stated otherwise in the Advertisement for Bids, all Bids which have been properly identified and received will be publicly opened and the prices read aloud. No evaluation of the Bids will be made at that time except for the announcement of the apparent low Bidder.

PART 19 ARTICLE 19 – BID VALIDITY

- 19.1 All Bids submitted shall be valid and binding on the Bidder for a period of sixty (60) days following the Bid submittal deadline and for any extension of time granted by the Bidder.

PART 20 ARTICLE 20 - EVALUATION OF BIDS -EVALUATION STANDARD

- 20.1 Bids will be evaluated by the Owner to determine which Bid is the lowest, responsive Bid by a responsible Bidder. The Owner, at its sole discretion, will base the evaluation on the

Base Bid or on the Base Bid plus selected Additive Bid(s).

PART 21 ARTICLE 21 – VERIFICATION OF BID PRICES

21.1 Prices set forth in the Bid will be reviewed by the Owner for mathematical accuracy. The Owner reserves the right to correct mathematical errors or complete mathematical calculations that are obvious on the face of the Bid. In the event of a discrepancy between a unit price and the extended amount for a Bid item, the unit price will control. The prices, corrected for mathematical errors, shall be used as the amount of the Bid items for evaluation and award purposes.

PART 22 ARTICLE 22 CLAIM OF ERROR

22.1 A Bidder claiming error in its Bid must submit supporting evidence including cost breakdown sheets within 24 hours of Bid opening and provide any other supporting documentation requested by the Owner. In the event the Bidder demonstrates an error in the Bid to the Owner's satisfaction, the Owner may allow the Bidder to withdraw its Bid.

PART 23 ARTICLE 23 RESPONSIVE BIDS

23.1 The Owner, in its sole discretion, reserves the right to determine Bid irregularities which render a Bid non-responsive, and to waive informalities and immaterial irregularities in the Bid. A Bid shall be considered irregular and may be rejected by the Owner as non-responsive for reasons including, but not limited to:

23.2 If the Bid form furnished or authorized is not used or is altered;

23.3 If the Bid form or any required supplemental documents are incomplete, contain any additions, deletions, conditions, or otherwise fail to conform to the Owner's requirements;

23.4 If the Bidder adds any provisions reserving the right to reject or accept the award, or enter into the contract;

23.5 If the Bid or Bid Guaranty is not properly executed, or shows an incorrect amount;

23.6 If the Bid fails to include a price for every Bid item;

23.7 If the Owner reasonably deems the Bid Guaranty inadequate; or

23.8 If the Owner deems any of the Bid prices to be excessively unbalanced either above or below the amount of a reasonable Bid price for the item of Work to be performed, to the potential detriment of the Owner.

PART 24 ARTICLE 24 BIDDER QUALIFICATIONS

24.1 It is the intent of the Owner to award a contract to the low responsible Bidder. Before award, the Bidder must meet the following Bidder responsibility criteria to be considered a responsible Bidder. The Bidder may be required by the Owner to submit documentation demonstrating compliance with the criteria. The Bidder must:

24.2 At the time of Bid submittal, have a current certificate of registration in compliance with chapter 18.27 RCW.

- 24.3 Have a current Washington Unified Business Identifier (UBI) Number.
- 24.4 If applicable:
- a. Have industrial insurance (workers' compensation) coverage for the Bidder's employees working in Washington, as required by Title 51 RCW;
 - b. Have a Washington Employment Security Number as required Title 50 RCW.
 - c. Have a Washington Department of Revenue state excise tax registration number, as required by Title 82 RCW.
- 24.5 Not be disqualified from bidding on any public works contract under RCW 39.06.010 or 39.12.065(3).
- 24.6 For public works projects subject to the apprenticeship utilization requirements of RCW 39.04.320, not have been found out of compliance by the Washington state apprenticeship and training council for working apprentices out of ratio, without appropriate supervision, or outside their approved work processes as outlined in their standards of apprenticeship under Chapter 49.04 RCW for the one-year period immediately preceding the first date of advertising for the project.
- 24.7 The Owner reserves the right to investigate the qualifications of any Bidder, including but not limited to, contacting any reference or any financial institution to verify that the Bidder is qualified to successfully complete the Work.
- 24.8 In order to verify that the Bidder has adequately incorporated all elements of the Work and the requirements of the Contract Documents in its Bid prices, the Bidder will make available upon request, for the Owner's review a complete itemization of its Bid, and clearly define all phases of its work.
- 24.9 Prior to award, if requested by the Owner, the Bidder and selected proposed subcontractors or suppliers shall attend a Bid evaluation conference and shall bring to the conference any documents requested by the Owner to evaluate the Bid and the Bidder's qualifications.
- 24.10 If the Owner deems any of the Bid prices to be excessively unbalanced either above or below the amount of a reasonable Bid price for the item of Work to be performed, to the potential detriment of the Owner.

PART 25 ARTICLE 25 SUPPLEMENTAL BIDDER RESPONSIBILITY CRITERIA

- 25.1 In addition to the Bidder responsibility criteria above, the Owner may adopt relevant supplemental criteria for determining Bidder responsibility applicable to a particular project which the Bidder must meet (RCW 39.04.350 (2)). Adopted criteria shall be stated in the Supplementary Conditions.
- 25.2 As evidence that the Bidder meets the Bidder responsibility criteria stated in the Supplementary Conditions, the apparent low Bidder must submit the requested documentation to the Owner within 48 hours of the Bid submittal deadline. In the interest of meeting the project's schedule, the Owner may request that the next lowest Bidder(s) also submit the documentation.
- 25.3 In the event Bidder fails to supply the supplemental information requested concerning responsibility within the time and manner specified, the Owner may base its determination

of responsibility on any available information related to the supplemental criteria or may find the Bidder not responsible. The Owner reserves the right to request such documentation from other Bidders also.

- 25.4 The Owner may conduct reference checks for the Bidder whose Bid is under consideration for award. In the event that information obtained from the reference checks:
- a. Reveals that the Bidder does not meet the Supplemental Bidder Responsibility Criteria; or
 - b. Indicates concerns about the Bidder's performance on projects identified as meeting the Supplemental Bidder Responsibility Criteria, which may include, but not be limited to the quality of construction, the Bidder's management of subcontractors, timeliness of required submittals, and safety record on the project; or
 - c. Indicates other concerns about the Bidder's ability to successfully perform the work,
- the Owner may determine that the Bidder is not a responsible Bidder. Prior to making such a determination that a Bidder is not responsible based on information received through reference checks, the Owner will discuss with the Bidder the information obtained from the references and provide the Bidder with the opportunity to offer explanations that may help inform whether the Owner declares the Bidder not responsible.
- 25.5 In conducting reference checks, the Owner may include itself as a reference if the Bidder has performed work for the Owner, even if the Bidder did not identify the Owner as a reference.
- 25.6 The Owner shall consider an overall accounting for determining Bidder responsibility. If the Owner determines the Bidder does not meet the Bidder responsibility criteria and is therefore not a responsible Bidder, the Owner shall notify the Bidder in writing with the reasons for its determination. If the Bidder disagrees with this determination, it may appeal the determination within 3 business days of receipt of the Owner's determination by presenting additional information to the Owner. The Owner will consider the additional information before issuing its final determination. If the final determination affirms that the Bidder is not responsible, the Owner will not execute a contract with any other Bidder until two 2 business days after the Bidder determined to be not responsible has received the final determination.
- 25.7 The Owner may award the contract to the next lowest Bidder who meets the Supplemental Bidder Responsibility Criteria and whose reference checks validate the ability of the Bidder to successfully perform the work. The Owner will use the same process in checking references for any Bidders other than the low Bidder.
- 25.8 Any Bidder, within five (5) business days before the Bid submittal deadline, may request that the Owner modify the Supplemental Criteria. The Owner will evaluate the request submitted by any potential Bidder and respond before the submittal deadline. If the evaluation results in a change of the criteria, the Owner will issue an addendum to the bidding documents identifying the new criteria.

PART 26 ARTICLE 26 COLLUSION

- 26.1 If the Owner determines that collusion has occurred among the Bidders, none of the Bids

of the participants in such collusion will be considered. The Owner's determination of collusion shall be conclusive.

PART 27 ARTICLE 27 RETURN OF BID GUARANTY

27.1 As soon as the Bid prices have been compared, the Owner will return the Bid Guaranty accompanying any Bids which, in the Owner's judgment, would not be considered for award. All other Bid Guaranties will be held until the Contract and bonds have been executed, after which all remaining Bid Guaranties, except those which have been forfeited, will be returned.

PART 28 ARTICLE 28 SINGLE BID RECEIVED

28.1 If the Owner receives a single responsive, responsible Bid, the Owner shall have the right, in its sole discretion, to conduct a price or cost analysis on such Bid. The Bidder shall promptly provide all cost or pricing data, documentation and explanation requested by the Owner to assist in such analysis. By conducting such analysis, the Owner shall not be obligated to accept the single Bid; the Owner reserves the right to reject such Bid or any portion thereof.

PART 29 ARTICLE 29 RIGHTS OF THE OWNER

29.1 The Owner reserves the right to accept the Bid of the lowest responsive, responsible Bidder, an "Alternative Bid" based upon plans and specifications prepared by the Bidder, to reject any or all Bids, republish the Advertisement for Bids, revise or cancel the work to be performed, or to do the work otherwise, if in the judgment of the Owner, the best interests of the Owner is served thereby.

PART 30 ARTICLE 30 – AWARD OF CONTRACT – NOTICE OF AWARD

- 30.1 The acceptance of a Bid will be evidenced by a written notice of award delivered to the Bidder whose Bid is accepted.
- 30.2 When the Owner gives a "Notice of Award" to the successful Bidder, it will be accompanied by two (2) unsigned counterparts of the Contract Agreement and all other Contract Documents. Within six (6) days thereafter, the Contractor shall sign and deliver two (2) counterparts of the Contract Agreement to the Owner with all other Contract Documents attached. Within six (6) days thereafter, the Owner will deliver one copy of all fully signed counterparts to the Contractor.
- 30.3 The Bidder shall not commence physical modification of the work site until the Owner has issued its Notice of Award, Notice To Proceed, and the Owner has received the executed agreement form and bonds and certificates of insurance meeting the requirements of the contract documents.

PART 31 ARTICLE 31 PERFORMANCE AND PAYMENT BONDS

31.1 The Bidder awarded this Contract shall furnish performance and payment bonds on forms set forth in Article 10 of the Standard General Conditions similar form acceptable to the Owner in the amount of 100% of the total Contract Sum as security for the faithful performance and completion of the Work. Such bonds shall be executed and sealed by a

duly licensed surety registered with the Washington State Insurance Commissioner, and the surety's name shall appear in the current Authorized Insurance Company List in the State of Washington published by the Office of the Insurance Commissioner. Attorneys-in-fact who sign bonds must file with each bond a certified and effectively dated copy of their Power of Attorney.

- 31.2 The scope of the performance and payment bonds shall not affect or alter the liabilities of the Contractor to the Owner under the terms of the Contract Documents.
- 31.3 The Owner may require the surety to appear and qualify itself upon the bond. If at any time the Owner determines, in its sole judgment, that the surety is insufficient, the Owner may require the Contractor to furnish additional surety in form and arrangement satisfactory to the Owner and in an amount not exceeding that originally required. Payments will not be made on the Contract until sufficient surety as required is furnished.
- 31.4 The person signing the performance bond on behalf of the Contractor shall also sign the Agreement form and bonds.

PART 32 ARTICLE 32 EXTENSION OF TIME

- 32.1 If the Agreement form is not executed or not submitted to the Owner within the time required and, in the Owner's discretion, circumstances warrant an extension of time, it may extend the time for execution of the Agreement form or for furnishing bonds and insurance certificates for a period not to exceed ten (10) additional days.

PART 33 ARTICLE 33 FAILURE TO EXECUTE CONTRACT

- 33.1 If the Bidder awarded the Contract fails to execute the Agreement form and furnish the required bonds and insurance certificates within ten (10) days from delivery of the notice to award, or declares in writing its intent not to execute the Contract, its Bid Guaranty shall be forfeited to the Owner and the Owner may issue notice of award to the second lowest responsible Bidder, and in like manner until the Agreement form and bonds are executed by a responsible Bidder to whom award is made, or further Bids are rejected. Forfeiture of the Bid Guaranty shall not limit the Owner's right to recover damages from the Bidder caused by the Bidder's failure to execute the Contract.

PART 34 ARTICLE 34 CANCELLATION OF AWARD

- 34.1 The Owner reserves the right to cancel the award of any Contract at any time before the execution of said Contract by all parties without liability to the Owner.

PART 35 ARTICLE 35 - WAGE RATE DETERMINATION.

- 35.1 This Project is subject to the provisions of the Washington State Public Works Law and related acts. The Contractor and every subcontractor on the project must pay the prevailing wage rate. The performance of any part of this contract shall be in accordance with the provisions of Chapter 39.12 RCW and to RCW 49.2 as amended. The rules and regulations of the Department of Labor and Industries and the schedule of prevailing wage rates for the locality or localities where this contract will be performed as determined by the Industrial Statistician of the Department of Labor and Industries, are by reference made a part of this contract as though fully set forth herein.

35.2 Bidders shall include in the Bid any filing fees required to comply with the applicable labor laws.

35.3 In case any dispute arises as to what are the prevailing rates of wages for work of a similar nature and such dispute cannot be adjusted by the parties of interest including labor and management representatives, the matter shall be referred for arbitration to the Director of the Department of Labor and Industries of the State and its decision therein shall be final and conclusive and binding on all parties involved in the dispute as provided for by RCW 39.12.060, as amended.

35.4 State of Washington Department of Labor Wage Rates are attached.

PART 36 ARTICLE 36 - RETAINAGE.

36.1 Provisions concerning retainage are set forth in Article 7.8 of the General Conditions.

END OF SECTION 002113

SECTION 003101 -PERMIT APPLICATION

1.1 PERMIT APPLICATION INFORMATION

- A. This Document with its referenced attachments is part of the Procurement and Contracting Requirements for Project. They provide Owner's information for Bidders' convenience and are intended to supplement rather than serve in lieu of the Bidders' own investigations. This Document and its attachments are not part of the Contract Documents.

PERMIT APPLICATION STATUS AND COST:

- B. Prior to bidding this project the Owner has applied for a City of Kennewick Building Department (BD) permit necessary for work covered under such a permit. The Owner will pay for the BD permit and the Bidder may presume the BD permit will be ready for issuance before the Notice to Proceed is issued. The Contractor must sign for the BD which then allows for direct communication between the Contractor and the City for the purposes of scheduling inspections.
- C. Any and all other permits including Washington State Labor & Industries Electrical permits shall be obtained by the contractor.

END OF SECTION 003101

SECTION 003103 - CULTURAL RESOURCE PROTECTION

1.1 CULTURAL RESOURCE PROTECTION BACKGROUND

- A. The Owner, Port of Kennewick has a Memorandum of Understanding with the Confederate Tribes of the Umatilla Indian Reservation (CTUIR) assuring that the Port's will be sensitive to the protection on any cultural resources found on Port property. **The Owner Port has built a strong relationship with the CTUIR and takes the commitment to protect these resources seriously.**

- B. The crucial concept **Disturbed and Observed**. Many sites have been previously disturbed as evidenced by the presences of utility pipes and/or conduits both active and abandoned, however observation was seldom part of prior exaction activities.

1.2 CULTURAL RESOURCE MONITORING PROCESS

- A. The Owner, Port of Kennewick contact the CTUIR who reviewed the project scope and determined the minimal volume of excavation activity did not warrant excavation observation **PROVIDE the Port and the Contractor strictly adhere to Section 007000 Article 3.22 Archaeological and Historical Preservation.**

END OF SECTION 003103

SECTION 004110 - BID FORM

BID FORM

PROJECT IDENTIFICATION: Port of Kennewick East 3rd Storage Building Select Demolition

THIS BID SUBMITTED TO: Port of Kennewick
350 Clover Island Drive, Suite 200
Kennewick, WA 99336

1. The undersigned Bidder proposes and agrees, if this Bid is accepted, to enter into an Agreement with the Owner in the form included in the Contract Documents to complete all Work as specified or indicated in the Contract Documents for the Contract Price and within the Contract Time indicated in this Bid and in accordance with the Contract Documents.
2. The Bidder accepts all of the terms and conditions of the Instructions to Bidders, including without limitation those dealing with the disposition of Bid Security. This Bid will remain open for 30 days after the day of Bid opening. The Bidder will sign the Contract Agreement and submit the Contract Security within 6 days after the date of the Owner's Notice of Award.
3. In submitting this Bid, the Bidder represents, as more fully set forth in the Contract Agreement, that:

(a) The Bidder has examined copies of all the Contract Documents and of the following addenda, if issued. Receipt of addenda is hereby acknowledged:

Date: Addenda Number:

_____	_____
_____	_____
_____	_____
_____	_____

(b) The Bidder has examined the site and locality where the Work is to be performed, the legal requirements (federal, state, and local laws, ordinances, rules and regulations) and the conditions affecting cost, progress or performance of the Work and has made such independent investigations as the Bidder deems necessary.

(c) Bidder has correlated the information known to Bidder, information and observations obtained from visits to the site, reports and drawings identified in the Contract Documents and all additional examinations, investigations, explorations, tests, studies and data with the Contract Documents.

(d) Bidder is familiar with and is satisfied as to all federal, state and local Laws and

Regulations that may affect cost, progress, performance and furnishing of the Work.

- (e) Bidder has given A/E written notice of all conflicts, errors, ambiguities or discrepancies in the Contract Documents and the written resolution thereof by A/E is acceptable to Bidder, and the Contract Documents are generally sufficient to indicate and convey understanding of all terms and conditions for performing and furnishing the Work for which this Bid is submitted.
 - (f) Where conflicts, errors, ambiguities or discrepancies have been discovered in or between Contract Documents and/or other related documents, and where said conflicts, etc., have not been resolved through the interpretations or clarifications by A/E as described in the Instructions to Bidders, because of insufficient time or otherwise, Bidder has included in the Bid the greater quantity or better quality of Work, or compliance with the more stringent requirement resulting in a greater cost.
 - (g) This Bid is genuine and not made in the interest of or on behalf of any undisclosed person, firm, or corporation and is not submitted in conformity with any agreement or rules of any group, association, organization, or corporation; the Bidder has not directly or indirectly induced or solicited any other Bidder to submit a false or sham bid; the Bidder has not solicited or induced any person, firm, or corporation to refrain from bidding; and the Bidder has not sought by collusion to obtain for himself any advantage over any other Bidder or over the Owner.
 - (h) The Bidder will complete the Work for the prices as set forth in the attached Bid Schedule.
 - (i) The Bidder agrees that the Work will be completed in accordance with the time schedule stated within Article 1.3 of the Contract Agreement. The Bidder accepts the provisions of the Contract Agreement as to liquidated damages in the event of failure to complete the work on time.
4. The following documents must be submitted in order for the Bid to be considered:
- a) Required Bid security in the form of certified check, cashier's check or surety bond in an amount not less than five (5%) percent of the amount of such bid proposal.
 - b) Non-Collusion and Debarment Affidavit
 - c) Anti-Discrimination Certificate.
 - d) Wage Law Compliance Affidavit
 - e) List of Subcontractors. (Must be provided to Owner within one hour after the published bid submittal deadline.)
 - f) Letter of Qualifications
5. Communications concerning this Bid shall be addressed to the address of the Bidder indicated below:

Phone () _____ Email _____

6. The terms used in this Bid which are defined in the General Conditions of the Construction Contract included as part of the Contract Documents have the meanings assigned to them in the General Conditions.

BID FORM COVER SHEET

PART 1 LUMP SUM (EXCLUDING SALES TAX)

\$ _____

PART 2 LUMP SUM (EXCLUDING SALES TAX), IN WORDS

The party by whom this Proposal is submitted and by whom the Contract will be entered into, in case this proposal is accepted, is a Corporation, Partnership, or Individual doing business at:

(Street)

(City) (State) (Zip Code)

The undersigned hereby certifies and represents to signing this Proposal on behalf of the bidder is authorized to do so.

Legal Name of Bidding Organization

Signature of Authorized Person

Partner of Firm or Official of Corporation

Title

Included Checklist:

- 1. Required Bid security.
- 2. List of Subcontractors.
- 3. Affidavit of Non-Collusion and Debarment.
- 4. Anti-Discrimination Certificate.
- 5. Wage Laws Compliance Affidavit.
- 6. Letter of Qualifications

END OF SECTION 004110

SECTION 004113 - SUBCONTRACTOR LIST

PROJECT IDENTIFICATION: Port of Kennewick East 3rd Storage Building Select Demolition

Within one hour after the published Bid submittal deadline, the Bidder shall provide a list of all subcontractors including the name, address, and work to be performed. In addition, the Bidder shall specify whether any subcontractor contract exceeds 10% of the Bid total. Successful awarded Bidders are obligated to use the subcontractors named on this list. Failure to name such subcontractors renders the General Contractor’s Bid non-responsive and void.

Subcontractor Name _____

Address _____

Work to be Performed _____

Subcontractor Name _____

Address _____

Work to be Performed _____

Subcontractor Name _____

Address _____

Work to be Performed _____

Subcontractor Name _____

Address _____

Work to be Performed _____

[ADDITIONAL SUBCONTRACTORS MAY BE LISTED ON A SEPARATE, ATTACHED PAGE]

END OF SECTION 004113

SECTION 004115 - ANTI-DISCRIMINATION CERTIFICATE

ANTI-DISCRIMINATION CERTIFICATE

Port of Kennewick
Port of Kennewick East 3rd Storage Building Select Demolition
Kennewick, Washington

STATE OF WASHINGTON

Benton County

The Bidder hereby certifies that no person shall be discriminated against in the bidding of the services and/or materials herein and that the Bidder shall not refuse employment to any person related to this Contract because of such person's sex, sexual orientation, age, ,race, creed, color, national origin, marital status, honorably discharged veteran or military status, or the presence of any sensory, mental or physical disability or the use of a trained dog guide or service animal by a person with a disability, or any other status protected by federal, state, or local law. Any such discrimination shall be deemed a violation of this Bid and shall render this Bid subject to forfeiture.

(Company Name)

(Contractor's Signature)

(Typed Name and Title)

SUBSCRIBED and SWORN to before me this ____ day of _____, 2024.

NOTARY PUBLIC in and for the State of
Washington, residing at _____

END SECTION 004115

SECTION 004117 - NON-COLLUSION AND DEBARMENT AFFIDAVIT

NON-COLLUSION AND DEBARMENT AFFIDAVIT

STATE OF WASHINGTON

COUNTY OF _____

I, the undersigned, an authorized representative of _____
(Firm, Association or Corporation)

being first duly sworn, certifies that the Bid above submitted is a genuine Bid and not a sham or collusive Bid or a Bid made in the interest or on behalf of any person not therein named; and it is further certified that the said Bidder has not directly or indirectly induced or solicited any Bidder on the above work or supplies to put in a sham Bid, or any other person or corporation to refrain from bidding; and that said Bidder has not in any manner sought by collusion to secure an advantage over other Bidder or Bidders.

(Company Name)

(Contractor's Signature)

(Typed Name and Title)

SUBSCRIBED and SWORN to before me this _____ day, of _____ 2024

NOTARY PUBLIC in and for the State of
Washington, residing at _____

END OF SECTION 004117

SECTION 004119 - WAGE LAWS COMPLIANCE AFFIDAVIT

WAGE LAWS COMPLIANCE AFFIDAVIT

STATE OF WASHINGTON

COUNTY OF _____

I, the undersigned, an authorized representative of _____
(Firm, Association or Corporation)

being first duly sworn, certifies that, within the three-year period immediately preceding the bid solicitation date for this Project, the Bidder is not a “willful” violator, as defined in RCW 49.48.082, of any provision of RCW chapters 49.46, 49.48, or 49.52, as determined by a final and binding citation and notice of assessment issued by the Department of Labor and Industries or through a civil judgment entered by a court of limited or general jurisdiction.

(Company Name)

(Contractor's Signature)

(Typed Name and Title)

SUBSCRIBED and SWORN to before me this _____ day of _____, 2024.

NOTARY PUBLIC in and for the State of
Washington, residing at _____

END OF SECTION 004119

SECTION 005000 – PUBLIC WORK CONTRACT

**PORT OF KENNEWICK
PUBLIC WORKS CONTRACT**

THIS PUBLIC WORKS CONTRACT (“Contract” or “Agreement”) dated _____ is effective on the date the Contract is fully executed by the Parties (“Effective Date”). The Parties to this Contract are the PORT OF KENNEWICK, a Washington municipal corporation (“Port”), and _____, a _____ (“Contractor”).

RECITALS

- A. The Port desires to retain an independent contractor to furnish all labor and materials necessary to perform work at Port of Kennewick East 3rd Storage Building Select Demolition Project; and
- B. The Contractor has the requisite skill and experience to perform such work and has submitted a bid proposal dated October 1, 2024, to complete such work (“Proposal”).

NOW, THEREFORE, the parties (“Parties”) agree to the following terms and conditions:

AGREEMENT

1. WORK PERFORMED BY CONTRACTOR

- 1.1 Scope of Work. Contractor shall perform all work and furnish all tools, materials, supplies, equipment, labor and other items incidental thereto necessary for the construction and completion of the work, more particularly described in the Contract Documents and in the attached **Exhibit A** “Scope of Work”.
- 1.2 Contract Documents. *The Contract Documents consist of Contract Documents and Specifications dated August, 2024, including Invitation for Bids, Instruction to Bidders, Permit Application, Cultural Resource Protection, Bid Form, Sub-Contractor List, Anti-Discrimination Certificate, Non-Collusion and Debarment Affidavit, Wage Laws Compliance Affidavit, Public Works Contract, Public Works Contract General Terms and Conditions, Port’s Policy and Procedures Manual, Submittal Procedures, Technical Specifications and the drawings prepared by CJKT Architects bearing the name Port of Kennewick East 3rd Storage Building Select Demolition, Notice of Award, Notice to Proceed, Payment Bond and Performance Bond all of which are incorporated by reference herein (“Work”). The Work shall be completed to the Port’s satisfaction, within the time period prescribed by the Port and pursuant to the direction of the Port Representative or his or her designee.*

A Modification is (1) a written amendment to the Contract signed by both parties, (2) a Change Order, (3) a Construction Change Directive or (4) a written order for a minor change in the Work issued by Port. Unless specifically enumerated in the Contract, the Contract Documents do not include other documents such as bidding requirements (advertisement or invitation to bid, Instructions to Bidders, sample forms, or portions of Addenda relating to bidding requirements).

- 1.3 Completion Date. *The Work shall be commenced within 7 calendar days of receipt by the Contractor of the Port's Notice to Proceed and shall be Substantially Completed 150 calendar days after the Notice to Proceed, (the "Contract Time") as may be extended in accordance with the Contract Documents. In the event the Work is not completed within the time specified, Contractor agrees to pay to the Port liquidated damages in the amount set forth in Section 1.4 of this Contract and in the Public Works Contract Terms and Conditions, incorporated fully by reference herein.*
- 1.4 Liquidated Damages. Timely performance and completion of the Work is essential to Port and the time limits stated in the Contract are of the essence. Port will incur serious and substantial damages if Substantial Completion of the Work does not occur within the Contract Time.
- Final Acceptance of the Work is essential to Port and the time limits as identified by Port are of the essence. Port will incur serious and substantial damages if Final Acceptance of the Work does not occur as Port requires.
- The Parties acknowledge that the Contractor's failure to achieve Substantial Completion or Final Acceptance within the timeframe provided by this Contract will cause the Port to incur substantial economic damages and losses of types and in amounts which are impossible to compute and ascertain with certainty, and that liquidated damages represent a fair, reasonable and appropriate estimate thereof. Accordingly, in lieu of actual damages for such delay, the Contractor agrees that liquidated damages may be assessed and recovered by the Port as against the Contractor and its surety, in the event of delayed completion. Contractor shall be liable to the Port for payment of liquidated damages in the amount of One Thousand Dollars (\$1,000) for each day that completion of the Scope of Work is delayed beyond the time specified in this Contract as adjusted for time extensions approved in writing by the Port. Such liquidated damages are intended to represent estimated actual damages and are not intended as a penalty. Contractor shall pay them to the Port without limiting the Port's right to terminate this agreement for default as provided elsewhere herein. Assessment of Liquidated Damages shall not release the Contractor from any further obligations or duties pursuant to the Contract Work.
- 1.5 Performance Standard. Contractor shall perform the Work in a manner consistent with accepted practices for highly skilled and competent contractors performing same or similar work in the same or similar locality.
- 1.6 Compliance with Laws. Contractor shall perform the Work in accordance with all applicable federal, state, City of Kennewick and Port laws, including but not limited to all City of Kennewick and Port ordinances, resolutions, standards or policies, as now existing or hereafter adopted or amended, Washington State Department of Revenue Rule 171, and obtain all necessary permits and pay all permit, inspection or other fees, at its sole cost and expense.
- 1.7 Utility Location. Contractor is responsible for locating any underground utilities affected by the Work and is deemed to be an excavator for purposes of Chapter 19.122 RCW, as amended. Contractor shall be responsible for compliance with Chapter 19.122 RCW, including utilization of the "one call" locator system before commencing any excavation activities.

- 1.8 Air Environment. Contractor shall fully cover any and all loads of loose construction materials including without limitation, sand, dirt, gravel, asphalt, excavated materials, construction debris, etc., to protect said materials from air exposure and to minimize emission of airborne particles to the ambient air environment.

2. TERM

- 2.1 This Contract shall commence on the Effective Date and continue until the Work is complete, and formally accepted by Port, and all warranties have expired.

3. REQUISITE SKILL

- 3.1 The Contractor warrants that it has the requisite skill to complete the Work, and is appropriately accredited and licensed by all applicable agencies and governmental entities, including but not limited to being registered to do business in the State of Washington. Contractor represents that it has visited the Project and is familiar with all of the plans and specifications in connection with the completion of the Work.

4. COMPENSATION

- 4.1 Total Compensation. In consideration of the Contractor performing the Work, the Port agrees to pay the Contractor an amount not to exceed _____ Dollars (\$ _____), plus applicable Washington State sales tax, based on the Proposal submitted by Contractor dated February 5, 2024 and as may be adjusted under the Contract Documents (“Total Compensation”).

- 4.2 Contractor Responsible for Taxes and Compliance with Washington State Department of Revenue Rule 171. Except as otherwise stated in the Contract Documents, the Contractor shall be solely responsible for the payment of any taxes imposed by any lawful jurisdiction as a result of the performance and payment of this Contract. The Contractor is solely responsible for compliance with Washington State Department of Revenue Rule 171.

- 4.3 Method of Payment. Payment by the Port for the Work will only be made after the Work has been completed and an invoice is submitted in a form satisfactory to the Port, and such invoice is approved by the appropriate Port Representative. Payment shall be made within thirty (30) days of receipt of Port approval. The Contractor’s acceptance of such payment for the Work shall constitute full compensation for the performance of the Work. Invoices shall be submitted via email to accountspayable@portofkennewick.org.

Contractor shall be required to complete all requirements set forth in the General Terms and Condition before the final invoice will be processed for payment.

- 4.4 Retainage. Pursuant to Chapter 60.28 RCW, five percent (5%) of the Total Compensation shall be retained by the Port to assure payment of Contractor’s state taxes as well as payment of subcontractors, suppliers and laborers. Upon execution of this Contract, Contractor shall complete, execute and deliver to the Port the Contractor’s Retainage Agreement set forth in the Contract Documents. No payments shall be made by the Port from the retained percentage fund (“Fund”) nor shall the Port release any retained percentage escrow account to any person, until the Port has

received from the Department of Revenue a certificate that all taxes, increases, and penalties due from the Contractor and all taxes due and to become due with respect to the Contract have been paid in full or that they are, in the Department's opinion, readily collectible without recourse to the State's lien on the retained percentage. Upon non-payment by the general contractor, any supplier or subcontractor may file a lien against the retainage funds, pursuant to Chapter 60.28 RCW. Subcontractors or suppliers are required to give notice of any lien within thirty (30) days of the completion of the Work and in the manner provided in RCW 39.08.030. Within sixty (60) days after completion of all Work on this Contract, the Port shall release and pay in full the money held in the Fund, unless the Port becomes aware of outstanding claims made against this Fund.

- 4.5 City of Kennewick Permit Bond. The Contractor shall be responsible for obtaining the City of Kennewick's one-year permit bond in the amount of five percent (5%) of the Project cost, or such other amount as may be determined by the City.

5. EQUAL OPPORTUNITY EMPLOYER

- 5.1 In all Contractor services and Work, programs or activities, and all Contractor hiring and employment made possible by or resulting from this Contract, there shall be no discrimination by Contractor or by Contractor's employees, agents, subcontractors or representatives against any person because of the person's sex, sexual orientation, age, race, creed, color, national origin, marital status, honorably discharged veteran or military status, or the presence of any sensory, mental or physical disability or the use of a trained dog guide or service animal by a person with a disability, or any other status protected by federal, state, or local law, unless based upon a bona fide occupational qualification in relationship to hiring and employment. This requirement shall apply, but not be limited to the following: employment, advertising, layoff or termination, rates of pay or other forms of compensation, and selection for training, including apprenticeship. Contractor shall not violate any of the terms of Chapter 49.60 RCW, Title VII of the Civil Rights Act of 1964, the Americans with Disabilities Act, Section 504 of the Rehabilitation Act of 1973 or any other applicable federal, state or local law or regulation regarding non-discrimination. Any material violation of this provision shall be grounds for termination of this Contract by the Port and, in the case of the Contractor's breach, may result in ineligibility for further Port agreements.

6. INDEPENDENT CONTRACTOR/ASSIGNMENT

- 6.1 In the performance of the Work provided under this Contract, Contractor is an independent contractor with full authority to control and direct the performance of the details of the work, however, the results of the work contemplated herein must meet the approval of the Port and shall be subject to the Port's general rights of inspection and review to secure the satisfactory completion thereof.
- 6.2 No agent, employee, officer or representative of the Contractor shall be deemed to be an employee, agent, officer, or representative of the Port for any purpose, and the employees of the Contractor are not entitled to any of the benefits or privileges the Port provides for its employees. The Contractor will be solely and entirely responsible for its acts and for the acts of its agents, employees, officers, subcontractors or representatives during the performance of this Contract.

- 6.3 The Port may, at its sole discretion, require the Contractor to remove any employee, agent or servant from employment on this Project who, in the Port's sole discretion, may be detrimental to the Port's interest.
- 6.4 The Port has awarded this Contract to the Contractor due to its unique qualifications to perform the Work. The Contractor shall not assign or subcontract its performance under this Contract or any portions of this Contract without the prior written consent of the Port, which consent must be sought at least thirty (30) days prior to the date of any proposed assignment. In the event the Port consents to any such assignment or transfer, such consent shall in no way release the Contractor from any of its obligations or liabilities under this Contract.

7. INDEMNIFICATION

- 7.1 The Contractor shall defend (in a manner reasonably acceptable to the Port and through legal counsel reasonably satisfactory to the Port), indemnify, and hold harmless the Port, its officers, officials, agents, employees, and volunteers (“Indemnitees”) from and against any and all losses, demands, claims, damages, expenses, judgments or liabilities, including costs, attorneys’ fees, taxes, fines, penalties, interest or other awards, that may be imposed on, incurred by or asserted against Indemnitees, arising out of or in any manner connected with errors, negligent acts or omissions by Contractor, its servants, agents or employees, except for injuries and damages caused by the sole negligence of the Port, its officers, employees, agents, and volunteers.
- 7.2 In the event of liability for damages arising out of bodily injuries or damages to property caused by or resulting from the concurrent negligence of the Contractor, and the Port, its officers, employees, agents or volunteers, the Contractor’s liability and obligation to defend hereunder shall only be the proportionate extent of the Contractor’s negligence.
- 7.3 It is further agreed that the indemnification provided herein constitutes the Contractor’s waiver of immunity under Industrial Insurance, Title 51 RCW, solely for the purposes of this indemnification.
- 7.4 No liability shall attach to the Port by reason of entering into this Contract except as expressly provided herein.
- 7.5 This waiver has been mutually negotiated by the parties, and the provisions of this section shall survive the expiration or termination of this Agreement.
- 7.6 Port may, in its sole discretion, (1) withhold amounts sufficient to pay the amount of any claim for injury, and/or (2) pay any claim for injury of which Port may have knowledge, regardless of the formalities of notice of such claim, arising out of the performance of this Contract.
- 7.7 Any amount withheld will be held until the Contractor secures a written release from the claimant or satisfies any judgment on such claim. In addition, the Contractor shall reimburse and otherwise be liable for claims costs incurred by Port, including, without limitation, costs for claims adjusting services, attorneys, engineering, and administration.

- 7.8 In the event Port incurs any judgment, award, and/or costs arising therefrom, including attorneys' fees, to enforce the provisions of this article, all such fees, expenses, and costs shall be recoverable from the Contractor.

8. INSURANCE

- 8.1 The Contractor shall not commence work under this Contract until the Contractor has obtained all insurance required under this paragraph and such insurance has been approved by the Port.
- 8.2 All insurance policies shall be issued by companies authorized to do business under the laws of the State of Washington and have a Best's rating of at least A-VII. All insurance, other than Workmen's Compensation, to be maintained by the Contractor shall specifically include the Port as an "Additional Insured" and shall not be reduced or canceled without Thirty (30) days written prior notice to the Port.
- 8.3 *The Contractor shall maintain during the life of the Contract, an Industry Standard Commercial General Liability Policy or equivalent, including Premises / Operations, Products / Completed Operations, Blanket Contractual Liability and Personal Injury Coverage, Physical Property Damage Insurance and Worker's Compensation Insurance to protect the Port from claims for damages for bodily injury, including wrongful death, as well as from claims of property damage which may arise from any operations under this contract whether such operations be by the Contractor or by anyone directly employed by or contracting with the Port.*
- 8.4 Specific limits required:
No less than One Million Dollars (\$1,000,000) per occurrence and Two Million Dollars (\$2,000,000) aggregate.
- 8.4 Contractor's insurance policies shall contain an endorsement naming the Port as Additional Insured and an endorsement that specifically states the Contractor's insurance, including Contractor's Commercial General Liability policy, shall be primary, and not contributory, with any other insurance maintained by the Port.
- 8.5 Commercial General Liability Insurance shall be endorsed to include a "cross liability", indicating essentially that "except with respect to the limits of insurance, and any rights or duties specifically assigned in this coverage part to the first named insured, this insurance applies as if each named insured were the only named insured, and separately to each insured against whom claims are made or suit is brought." The policy shall also be endorsed to include stop gap employer's liability coverage with minimum limits as follows: Each accident \$ 1,000,000.
- 8.6 The Contractor shall maintain, during the life of this Contract, Business Automobile Liability Insurance or equivalent in the amount of \$1,000,000 Bodily Injury and Property Damage per Accident to protect the Port from claims which may arise from this performance of this Contract, whether such operations be by the Contractor or by anyone directly or indirectly employed by the Port.
- 8.7 The Contractor shall secure its liability for industrial injury to its employees in accordance with the provisions of Title 51 of the Revised Code of Washington. The

Contractor shall submit a copy of its certificate of coverage to the Department of Labor and Industries prior to the commencement of Work.

- 8.9 Industrial Insurance Waiver. With respect to the performance of this Contract and as to claims against the Port, its officers, agents, employees and volunteers, the Contractor expressly waives its immunity under Title 51 of the Revised Code of Washington, the Industrial Insurance Act, for injuries to its employees and agrees that the obligations to indemnify, defend and hold harmless provided in this Agreement extend to any claim brought by or on behalf of any employee of the Contractor against the Port. This waiver is mutually negotiated by the parties to this Contract.

9. PERFORMANCE/PAYMENT BOND OR ADDITIONAL RETAINAGE

- 9.1 Pursuant to RCW 39.08.010, Contractor shall provide Performance Bond and Payment Bond each in an amount equal to 100% of the amount of this Contract to cover the performance of all provisions of this Contract and the payment of all laborers and suppliers. The Contract bonds shall be in a form set forth in the Contract Documents. The Contract bond shall assure that the Contractor will faithfully perform all of the provisions of the Contract as well as pay all laborers, mechanic subcontractors, materialmen and suppliers. Contractor's obligations under this Contract shall not be limited to the bond amount.

10. SAFETY

- 10.1 Contractor shall take all necessary precautions for the safety of employees on the work site and shall comply with all applicable provisions of federal, state and municipal safety and health laws and codes, including without limitation, all OSHA/WISHA requirements, Safety and Health Standards for Construction Work (Chapter 296-155 WAC), General Safety and Health Standards (Chapter 296-24 WAC), and General Occupational Health Standards (Chapter 296-62 WAC). Contractor shall erect and properly maintain, at all times, all necessary guards, barricades, signals and other safeguards at all unsafe places at or near the Work for the protection of employees and the public, safe passageways at all road crossings, crosswalks, street intersections, post danger signs warning against known or unusual hazards and do all other things necessary to prevent accident or loss of any kind. Contractor shall protect from damage all water, sewer, gas, steam or other pipes or conduits, and all hydrants and all other property that is likely to become displaced or damaged by the execution of the Work.

11. PREVAILING WAGES

- 11.1 Wages of Employees. This Contract is subject to the minimum wage requirements of Chapter 39.12 of the Revised Code of Washington, as now existing or hereafter amended or supplemented. In the payment of hourly wages and fringe benefits to be paid to any of Contractor's laborers, work persons and/or mechanics, Contractor shall not pay less than the "prevailing rate of wage" for an hour's work in the same trade or occupation in the locality within the State of Washington where such labor is performed, as determined by the Industrial Statistician of the Department of Labor and Industries of the State of Washington. Prevailing wages paid pursuant to this Agreement shall be the prevailing wage rates which are in effect on the date when the

bids, proposals, or quotes were required to be submitted to the Port. The State of Washington prevailing wage rates applicable for this public works project may be found at the following website address of the Department of Labor and Industries: <https://fortress.wa.gov/lni/wagelookup/prvWagelookup.aspx>.

- 11.2 Reporting Requirements. Contractor shall comply with all reporting requirements of the Department of Labor and Industries of the State of Washington. Upon the execution of this Contract, Contractor shall complete and file a Statement of Intent to Pay Prevailing Wages with the Department of Labor and Industries. Pursuant to RCW 39.12.040, payments will not be made to Contractor until Statement of Intent's are approved by L&I for Contractor and all Subcontractors. If requested by the Port, the Contractor shall provide certified payroll records for its employees and the employees of its subcontractors. Upon completion of the Work, Contractor shall complete and file an Affidavit of Wages Paid with the Department of Labor and Industries. Contractor shall deliver copies of both the Statement of Intent to Pay Prevailing Wages and the Affidavit of Wages Paid, certified by the Department of Labor and Industries, to the Port.

12. SUBCONTRACTOR RESPONSIBILITY

- 12.1 Contractor shall verify responsibility criteria for each first tier subcontractor, and a subcontractor of any tier that hires other subcontractors must verify responsibility criteria for each of its subcontractors. Verification shall include that each subcontractor, at the time of subcontract execution, meets the responsibility criteria listed in the Instructions to Bidders and possesses an electrical contractor license, if required by chapter 19.28 RCW, or an elevator contractor license, if required by chapter 70.87 RCW. This verification requirement must be included in every public works subcontract or every tier.

13. OWNERSHIP OF ENGAGEMENT WORK PRODUCT

- 13.1 The Port owns all rights, including without limitation, any intellectual property rights in and to everything Contractor makes, conceives, develops, discovers reduces to practice or fixes in a tangible medium of expression, alone or with others in the course of Contractor's engagement by Port including without limitation, all deliverables as well as Contractor's reports, summaries, photographs, analyses, documents, worksheets, sketches, or models, as well as any concepts, ideas, procedures, and inventions ("Engagement Work Product"). Contractor, on behalf of itself and its agents, will assign to the Port and hereby does assign to the Port all rights to all Engagement Work Product, including all copyrights, patent rights and trade secret rights, vested and contingent, including without limitation with respect to each of the foregoing renewal rights and rights to license and assign. At the Port's direction and expense, Contractor will execute all documents and take all actions necessary or convenient for the Port to document, obtain, maintain or assign its rights in and to Engagement Work Product. In the event that Contractor incorporates or uses any other intellectual property in any Engagement Work Product, Contractor grants the Port a perpetual, world-wide, royalty-free, non-exclusive license under its rights to such intellectual property to make, use, sell, distribute, modify and sublicense such intellectual property.

- 13.2 In the event of the Contractor's default, or in the event that this Contract is terminated prior to its completion, the Engagement Work Product, along with a summary of the Work performed to date of default or termination, shall become the property of the Port, and tender of the work product and summary shall be a prerequisite to final payment under this Contract. The Summary of Work provided shall be prepared at no additional cost, if the Contract is terminated through default by the Contractor. If the Contract is terminated through convenience by the Port, the Port agrees to pay Contractor for the preparation of the Summary of Work provided.

14. CONFIDENTIALITY AND PUBLIC RECORDS ACT

- 14.1 Contractor acknowledges that the Port is an agency subject to Chapter 42.56 RCW "Public Records Act." All preliminary drafts or notes prepared or gathered by the Contractor, and recommendations of the Contractor are exempt prior to the acceptance by the Port.
- 14.2 If the Contractor becomes a custodian of nonexempt public records of the Port and request for such records is received by the Port, the Contractor shall respond to the request by the Port for such records within five (5) business days by either providing the records, or by identifying in writing the additional time necessary to provide the records with a description of the reasons why additional time is needed. Such additional time shall not exceed twenty (20) working days unless extraordinary good cause is shown.

15. BOOKS AND RECORDS

- 15.1 The Contractor agrees to maintain books, records, and documents which sufficiently and properly reflect all direct and indirect costs related to the performance of this Contract and such accounting procedures and practices as may be deemed necessary by the Port to assure proper accounting of all funds paid pursuant to this Contract. These records shall be subject at all reasonable times to inspection, review or audit by the Port, its authorized representative, the State Auditor, or other governmental officials authorized by law to monitor this Contract.

16. CLEAN UP

- 16.1 At any time ordered by the Port and immediately after completion of the Work, the Contractor shall, at its own expense, clean up and remove all refuse and unused materials of any kind resulting from the Work. In the event the Contractor fails to perform the necessary clean up, the Port may, but in no event is it obligated to, perform the necessary clean up and the costs thereof shall be immediately paid by the Contractor to the Port and/or the Port may deduct its costs from any remaining payments due to the Contractor.

17. DISPUTE RESOLUTION

- 17.1 This Contract has been and shall be construed as having been made and entered into and delivered within the State of Washington and it is agreed by each party hereto that this Contract shall be governed by the laws of the State of Washington.

- 17.2 In the event of a dispute regarding the enforcement, breach, default, or interpretation of this Contract, the Port and Contractor, or their designees, shall first meet in a good faith effort to resolve such dispute. In the event the dispute cannot be resolved by agreement of the parties, said dispute shall be first submitted to formal mediation through the American Arbitration Association mediation services, unless the parties agree to utilize another mediation service. If the dispute is not resolved through the formal mediation process, the parties agree to submit the dispute to binding arbitration utilizing the American Arbitration Association's arbitration rules for Construction, Real Estate & Environmental. Venue for such mediation and arbitration shall be Kennewick, Benton County, Washington, unless otherwise agreed between the parties. The prevailing party shall be entitled to its reasonable attorney fees and costs as additional award and judgment against the other.
- 17.3 As provided in RCW 39.12.060, in the event a dispute regarding the applicable prevailing wage rate cannot be resolved by the Port and Contractor, said dispute regarding the prevailing wage rate shall be referred for arbitration to the director of the Washington Department of Labor and Industries and his or her decision therein shall be final and conclusive and binding on all parties involved in the dispute.

18. GENERAL PROVISIONS

- 18.1 This Contract and the Contract Documents contain all of the agreements of the Parties with respect to any matter covered or mentioned in this Contract and no prior agreements or understandings shall be effective for any purpose.
- 18.2 No provision of this Contract may be amended except by written agreement of the Parties. Any provision of this Contract which is declared invalid, void or illegal shall in no way affect, impair, or invalidate any other provision hereof and such other provisions shall remain in full force and effect.
- 18.3 This Contract shall be binding upon and inure to the benefit of the Parties' successors in interest, heirs and assigns.
- 18.4 Failure of the Port to declare any breach or default immediately upon occurrence thereof, or delay in taking any action in connection with, shall not waive such breach or default.
- 18.5 This Contract shall be governed by and interpreted in accordance with the laws of the State of Washington.
- 18.6 Each individual executing this Contract on behalf of the Port and Contractor represents and warrants that such individuals are duly authorized to execute this Contract.
- 18.7 Time is of the essence of this Contract and each and all of its provisions in which performance is a factor. Adherence to completion dates is essential to the Contractor's performance of this Contract.

IN WITNESS WHEREOF, the Parties have executed this Contract the _____ day of _____, 20____.

[CONTRACTOR]

PORT OF KENNEWICK

By: _____

By: _____

Tim Arntzen, CEO

Printed Name: _____

Title: _____

Date: _____

Date: _____

Contractor's License No. _____

Approved as to form:

Approved by CFO or Designee:

By: _____

By: _____

Carolyn A. Lake, Port Counsel/Date

Nick Kooiker, CFO/Date

Attachments:

- Exhibit A – Scope of Work
- General Terms & Conditions

STATE OF WASHINGTON)
) ss.
COUNTY OF BENTON)

On _____, 2024, before me, a Notary Public in and for the State of Washington, personally appeared _____, personally known to be the _____ [Title] of _____ [Corporation/LLC name], the corporation that executed the within and foregoing instrument, and acknowledged said instrument to be the free and voluntary act and deed of said corporation for the uses and purposes mentioned and on oath stated that he was authorized to execute said instrument.

IN WITNESS WHEREOF, I have hereunto set my hand and official seal the day and year first above written.

Print Name _____
NOTARY PUBLIC in and for Washington
residing at _____
My appointment expires _____

STATE OF WASHINGTON |
 | ss.
COUNTY OF BENTON |

I certify that I know or have satisfactory evidence that Tim Arntzen is the person who appeared before me, and said person acknowledged that said person signed this instrument, on oath stated that said person was authorized to execute the instrument and acknowledged it as the Chief Executive Officer of Port of Kennewick, a municipal corporation, to be the free and voluntary act of such entity for the uses and purposes mentioned in the instrument.

Dated this _____ day of _____, 2024.

(Signature of Notary)

(Legibly Print or Stamp Name of Notary)

Notary public in and for the State/Commonwealth of _____,
residing at _____
My appointment expires _____

EXHIBIT A SCOPE OF WORK

The project will repair a fire damaged building by removing the damaged areas and leaving areas to remain for storage use. Of the existing 12,000sqft Warehouse building and 1,223sqft office area, 7,200sqft of the warehouse and all of the office are to be removed.

The south wall of the remaining 4,800sqft building to remain will be treated with exterior weatherproof improvements and the remaining slab area will be fenced with gates and exterior security lighting will be added.

END OF SECTION 005000

SECTION 007000 - PUBLIC WORKS CONTRACT GENERAL TERMS AND CONDITIONS

**PUBLIC WORKS CONTRACT
GENERAL TERMS AND CONDITIONS
TABLE OF CONTENTS**

ARTICLE 1: GENERAL PROVISIONS..... 4

 1.0. DEFINITIONS4

 1.1. INTENT AND INTERPRETATION OF THE DOCUMENTS8

 1.2. ORDER OF PRECEDENCE.....9

 1.3. CLARIFICATION OF DRAWINGS AND DETAIL DRAWINGS9

ARTICLE 2: PORT..... 9

 2.0. AUTHORITY.....9

 2.1. INFORMATION SUPPLIED BY PORT11

 2.2. WORK BY PORT OR SEPARATE CONTRACTORS11

ARTICLE 3: CONTRACTOR..... 11

 3.0. CONTRACTOR REPRESENTATIONS11

 3.1. GENERAL DUTIES12

 3.2. DUTY TO INSPECT CONTRACT DOCUMENTS12

 3.3. COMMUNICATIONS13

 3.4. CONTRACTOR’S SUPERVISION AND EMPLOYEES13

 3.5. CONTRACTOR’S DUTY WHEN PORT PERFORMS WORK ON-SITE.....14

 3.6. SUBCONTRACTORS AND SUPPLIERS.....14

 3.7. SCHEDULE OF WORKING HOURS15

 3.8. RECORD DOCUMENTS15

 3.9. COST RECORDS.....16

 3.10. MAINTENANCE AND INSPECTION OF DOCUMENTS16

 3.11. MAINTENANCE AND SITE CLEANUP19

 3.12. PROTECTION OF EXISTING STRUCTURES, EQUIPMENT,
 VEGETATION, UTILITIES, AND IMPROVEMENTS.....19

 3.13. PERMITS, LAWS AND REGULATIONS20

 3.14. PATENTS AND ROYALTIES.....20

 3.15. CONTRACTOR’S CERTIFICATION21

 3.16. DEVIATION FROM CONTRACT22

 3.17. OPERATIONS, MATERIAL HANDLING, AND STORAGE AREAS22

 3.18. CONTRACTOR’S OVERALL RESPONSIBILITY FOR PROTECTION OF
 WORK, PROPERTY, AND PERSONS22

 3.19. PROTECTION OF PERSONS.....23

 3.20. SAFETY PROGRAM24

 3.21. STORAGE OF CONTRACTOR’S PROPERTY.....24

 3.22. ARCHAEOLOGICAL AND HISTORICAL PRESERVATION24

 3.23. WATER POLLUTION CONTROL REQUIREMENTS.....25

 3.24. EASEMENTS.....25

ARTICLE 4: ADMINISTRATION OF THE CONTRACT..... 25

 4.0. TIME OF ESSENCE25

 4.1. WORK PROGRESS.....25

 4.2. SCHEDULE OF VALUES.....26

4.3. PROJECT SCHEDULE.....26

4.4. SUBMITTALS28

4.5. REQUESTS FOR INFORMATION29

4.6. TESTS, INSPECTIONS, AND ACCESS TO THE WORK.....30

4.7. CORRECTION OF WORK OR DAMAGED PROPERTY31

4.8. SUBSTITUTION OF PRODUCTS & PROCESSES.....32

ARTICLE 5: CHANGES TO THE CONTRACT 33

5.0. GENERAL.....33

5.1. CONTRACTOR’S REQUEST FOR A CHANGE ORDER.....35

5.2. DIFFERING SITE CONDITIONS.....36

5.3. ACCELERATION.....37

5.4. SUSPENSION OF WORK.....38

5.5. FORCE MAJEURE39

5.6. CHANGE ORDERS.....39

5.7. PORT REQUEST FOR A CHANGE PROPOSAL40

ARTICLE 6: TIME AND PRICE ADJUSTMENTS..... 41

6.0. CHANGE IN THE CONTRACT TIME41

6.1. CHANGE IN THE CONTRACT PRICE.....42

6.2. METHOD TO CALCULATE ADJUSTMENTS TO CONTRACT PRICE44

6.3. ALLOWABLE COSTS46

ARTICLE 7: PAYMENT AND COMPLETION 49

7.0. APPLICATIONS FOR PAYMENT.....49

7.1. PAYMENTS.....50

7.2. PAYMENT WITHHELD.....50

7.3. TITLE51

7.4. SUBSTANTIAL COMPLETION PROCEDURE51

7.5. FINAL INSPECTION AND FINAL PUNCH LIST.....53

7.6. REQUIREMENTS FOR FINAL APPLICATION FOR PAYMENT.....53

7.7. COMPLETION/FINAL ACCEPTANCE54

7.8. RETAINAGE.54

7.9. WARRANTY AND GUARANTY55

7.10. PRIOR OCCUPATION.....55

ARTICLE 8: TERMINATION 55

8.0. PORT’S RIGHT TO TERMINATE CONTRACT55

8.1. PORT’S RIGHT TO STOP THE WORK FOR CAUSE58

ARTICLE 9: CLAIMS AND DISPUTE RESOLUTION..... 58

9.0. CONTRACTOR CLAIMS58

9.1. CONTRACTOR’S BURDEN OF PROOF ON CLAIM.....61

9.2. DISPUTE RESOLUTION.....62

ARTICLE 10: MISCELLANEOUS..... 62

10.0. CONTRACTOR’S PERFORMANCE AND PAYMENT BOND.....62

10.1. INDEMNIFICATION/HOLD HARMLESS.....62

10.2. COMPENSATION, WAGES, BENEFITS AND TAXES.....63

10.3. SUCCESSORS AND ASSIGNS.....63

10.4. THIRD PARTY AGREEMENTS64

10.5. NONWAIVER OF BREACH64

10.6. NOTICE TO PORT OF LABOR DISPUTES.....64
10.7. LIQUIDATED DAMAGES AGAINST CONTRACTOR64
10.8. HEADINGS65
10.9. CHOICE OF LAW65
10.10. SEVERABILITY65
10.11. NONDISCRIMINATION65
10.12. PUBLIC RECORDS.....65
10.13. CONFIDENTIALITY; PUBLICITY; SECURITY66

ARTICLE 1: GENERAL PROVISIONS**1.0. DEFINITIONS**

- A. **“Addendum”** or **“Addenda.”** Alteration or clarification of the plans or specifications provided to bidders by Port prior to bid time, which becomes part of the Contract Documents when the Contract is executed.
- B. **“Claim.”** A written demand by the Contractor seeking (1) a change to Contract Price; (2) a change of Contract Time; (3) a payment of money or damages; and/or, (4) any other relief arising out of or relating to this Contract.
- C. **“Change Order.”** A written instrument designated to be a Change Order approved in writing by the Port which alters the Contract and identifies the following: (1) a change in the Work; (2) a change in Contract Price; and/or (3) a change in Contract Time.
- D. **“Change Proposal.”** A document prepared by the Contractor at the request of Port, which proposes changes to the Work and/or changes to the Contract Price and/or Contract Time. Port or Contractor initiate all requests for Change Proposals. All such Change Proposals must be approved in writing by the Port.
- E. The **“Contract”** or **“Contract Documents.”** The entire integrated agreement between Port and the Contractor for the performance of the Work. The Contract Documents are listed in the Port of Kennewick Public Works Contract and the Certificate of Acknowledgement provided to the Contractor.
- F. **“Contract Execution.”** occurs when Port Executive Director or his designee signs the Contract, which shall only occur after the Contractor signs the Contract.
- G. **“Contract Price”** means the total amount payable by Port to the Contractor for performance of the Work in accordance with the Contract.
- H. **“Contractor’s Representative.”** The individual who has authority to obligate the Contractor and who is identified in the Public Works Contract.
- I. **“Contract Time.”** The number of days or the specific date set forth in the Contract to achieve Substantial Completion of the Work.
- J. **“Contract Work”** or **“Work.”** The labor, materials, equipment, supplies, services, other items, and requirements of the Contract necessary for the execution, completion and performance of all work within the Contract by the Contractor to the satisfaction of Port.
- K. **“Contractor.”** The individual, association, partnership, firm, company, corporation, or combination thereof, including joint ventures, contracting with Port to do the Contract Work.
- L. **“Critical Path.”** The longest, continuous sequence of interrelated activities that begins at the start of the Project (Notice to Proceed) and extends to Substantial Completion of the Project. These activities are critical because delay to an activity on this path will extend Contract Time.

- M. **“Day.”** A calendar day, unless otherwise specified.
- N. **“Differing Site Conditions.”** (1) Subsurface or latent physical conditions at the site which differ materially from those indicated in the Contract Documents (Type I), or (2) Unknown physical conditions at the Site, of an unusual nature, which differ materially from those ordinarily encountered and generally recognized as inherent in the construction activities of the character provided for in the Contract (Type II).
- O. **“Field Directive.”** A document, titled Field Directive, prepared by Port directing the Contractor to proceed promptly with specific work and shall not, in and of itself, constitute a Change Order or entitlement to an adjustment in Contract Time and/or Contract Price.
- P. **“Final Acceptance”** and/or **“Completion.”** Written acceptance of the Project by Port.
- Q. **“Force Majeure.”** An event that is unforeseeable at the time of Contract Execution and that is beyond the reasonable control of the Contractor and Port and includes:
1. Natural Disaster declared by Governor of Washington or President of the United States, including but not limited to earthquakes;
 2. Acts or omissions of any government entity acting within its governmental capacity;
 3. Fire and/or flood for which the Contractor or its Subcontractors is not responsible;
 4. Quarantine or epidemic;
 5. Strike or defensive lockout;
 6. Unusually Severe Weather Conditions; and
 7. Acts of terrorism.
- R. **“Hazardous Material.”** Any pollutant, contaminant, toxic or hazardous waste, dangerous substance, potentially dangerous substance, noxious substance, toxic substance, flammable material, explosive material, radioactive material, urea formaldehyde foam insulation, asbestos, PCBs, or any other substances the removal of which is required, or the manufacture, preparation, production, generation, use, maintenance, treatment, storage, transfer, handling, or shipment of which is restricted, prohibited, regulated, or penalized by any and all federal, state, Port, or municipal statutes or laws and regulations promulgated thereunder, now or at any time hereafter in effect, including, but not limited to, the Comprehensive Environmental Response, Compensation, and Liability Act (42 U.S. C. §§ 9601, et seq.), the Hazardous Materials Transportation Act (49 U. S. C. §§ 1801, et seq.), the Resource Conservation and Recovery Act (42 U. S. C. §§ 6901, et seq.), the Federal Water Pollution Control Act (33 U. S. C. §§ 1251, et seq.), the Clean Air Act (42 U.S.C. §§ 7401, et seq.), the Toxic Substances Control Act, as amended (15 U.S.C. §§ 2601, et seq.), the Occupational Safety and Health Act (29 U. S. C. §§ 651, et

seq., and the Model Toxics Control Act (RCW 70.105), or similar state or local statute or code), as the laws have been amended and supplemented.

- S. **“Port”** or **“Owner”** may be used interchangeably and refer to the Port of Kennewick.
- T. **“Notice.”** A written document issued by the Port’s Project Representative or Contractor’s Representative which is submitted to the other party and delivered by:
1. Depositing in the U. S. Mail (or other method of commercial express mail), which notice shall be effective on the date of receipt;
 2. Service on the Parties’ representative or at the Contractor’s home office or field office, which notice shall be effective on the date of service; or,
 3. Facsimile or email to the Parties’ representative or Contractor’s home office or field office, which notice shall be effective upon receipt.
- U. **“Notice To Proceed.”** A written directive issued by Port authorizing the Contractor to perform some or all of the Work.
- V. **“Overhead.”** Charges that may be incurred or allocated in support of the Contract but are not part of the cost of directly performing the physical Contract construction activity. Overhead includes Site or Field Overhead and Home Office Overhead.

1. **Site or Field Office Overhead**

Site or Field Overhead costs are typically those costs that are related to, but are not limited to supervision, including general foremen and their supervisors, planners, schedulers, engineers, managers, etc. and the direct payroll costs of their project-related service, clerical salaries and their direct payroll costs, the costs of all vehicles, travel, meal and lodging costs associated with those personnel, Site or Field office and utility expense, expenses associated with all regulatory compliance, Hand and Other Small Tools provided by the Contractor for the use of its forces, all expendable supplies, and all other items incidental to or integral in supporting the physical completion of the Work.

2. **Home Office Overhead**

Home office Overhead costs are typically those that include all general office expenses. Such costs include, but are not limited to those associated with officer and office salaries and related payroll taxes and benefits, costs of office occupancy and maintenance, all supporting services (such as utilities, office machines computers, and related items and support) related to the home office function, business taxes and licenses, and all such other costs necessary to operate the business entity. Home office overhead includes unabsorbed home office overhead.

3. In addition to the above, whether treated as Site or Field Overhead or as Home Office Overhead, costs of any and all bonds, insurance(s), and taxes associated with this Contract are to be considered as Overhead. All items as those identified

above are to be treated as Overhead for this purpose regardless of how the Contractor chooses to account for them in its books of account.

4. Under no circumstances shall Port pay the Contractor for direct or allocated costs or charges for officer bonus and profit sharing, project personnel bonuses, charitable contributions, income taxes, or any costs relating to illegal activity.

- W. **“Parties.”** The Contractor and Port.
- X. **“Project.”** All activity relative to this Contract including activity of the Contractor, its Subcontractors, and Port.
- Y. **“Request for Change Order.”** A document, designated as a Request for a Change Order, prepared by the Contractor requesting either (1) a change in Contract Price; (2) a change in Contract Time; (3) a change in Contract Work; (4) a payment of money or damages; and/or, (5) any other relief arising out of or relating to this Contract.
- Z. **“Request for Information.”** A request from the Contractor to Port seeking an interpretation or a clarification of some requirement of the Contract Documents.
- AA. **“Site” or “Project Site.”** The location, at which construction, equipment or services furnished by the Contractor under the Contract will be performed, completed and/or delivered.
- BB. **“Subcontractor.”** An individual, firm, partnership, or corporation having- a contract, purchase order, or agreement with the Contractor, or with any Subcontractor of any tier for the performance of any part of the Contract. When Port refers to Subcontractor(s) in this document, for purposes of this document and unless otherwise stated herein, the term Subcontractor(s) includes, at every level and/or tier, all subcontractors.
- CC. **“Supplier(s).”** Any person or firm who is not performing work or supplying labor on Site and is engaged in the business of supplying a manufactured product or resource to Port, Contractor, or Subcontractors. The term Suppliers includes materialmen, manufacturers, and fabricators.
- DD. **“Substantial Completion.”** That stage in the progress of the Work where the Port has accepted in writing the Project as substantially completed which shall include but not be limited to the following requirements, unless any such requirement is waived in writing by the Port:
1. Port has full and unrestricted use and benefit of the Project for the purpose intended;
 2. All the systems and parts of the Contract Work are functional;
 3. Utilities are connected and operate normally;
 4. Only minor incidental work or correction or repair remains to complete all Contract requirements; and,

5. At Port's option, the Contractor has provided all easement releases as provided in Paragraph 3.24.
6. The Port has received all certificates of occupancy and any other permits, approvals, licenses and other documents from any governmental authority with jurisdiction necessary for beneficial occupancy of the project.

EE. **“Unusually Severe Weather Conditions.”** Defined and calculated as follows:

Ice, snow and other weather conditions, not described above, may be considered as unusually severe at the sole discretion of Port upon written request by the Contractor. Such written request shall describe in detail the weather conditions, identify the specific impacts resulting from the weather condition, and be submitted to Port within five (5) days of the onset of the unusually severe weather condition.

Precipitation (such as rain, hail or snow), low temperature, windstorms, ice, and other conditions which could reasonably have been anticipated from the National Weather Service historical records for the general locality of the Work shall not be construed as unusually severe weather.

For the purposes of this provision, a “month” shall mean a calendar month and a “week” shall mean a calendar week of Sunday through Saturday.

1.1. INTENT AND INTERPRETATION OF THE DOCUMENTS

- A. The Contract Documents constitute the entire and integrated agreement between the Parties hereto and supersede all prior negotiations, representations, or agreements, either written or oral.
- B. The Contract Documents shall not be construed to create a contractual relationship between any Parties other than Port and the Contractor. No contract between Port and a third party shall be construed to create any duty on the part of Port or such third party to the Contractor. The Contractor is not an intended or incidental beneficiary of any promises made in Port's contract with a third party, if any.
- C. The Contract Documents are intended to be complementary. What is required by one part of the Contract shall be as binding as if required by all. Should any conflict or inconsistency be found in the Contract Documents, Port shall resolve any such conflict or inconsistency in accordance with paragraph 1.2, Order of Precedence.
- D. The words “similar,” “typical” (or their equivalents) shall mean nearly corresponding or having a likeness. Such words shall not be construed to mean that all parts of the Work referred to are identical or substantially identical, or that such elements of the Work are connected identically or substantially identically to the rest of the Work. The Contractor has the responsibility to determine all details of the Work in relation to their location and connection to other parts of the Work. The singular includes the plural and vice versa. Male includes female and vice versa.
- E. The organization of the specifications into divisions, provisions and articles and the organization of the drawings shall not control the Contractor in dividing the Work among Subcontractors or in establishing the extent of Work to be performed by any trade.

1.2. ORDER OF PRECEDENCE

- A. Any conflict or inconsistency between the terms or conditions of the Contract Document shall be resolved by the following descending order of precedence (with 1 taking precedence over 2, 3, 4, 5, 6 and 7; 2 taking precedence over 3, 4, 5, 6 and 7; and so forth):
 - 1. Change Orders;
 - 2. The signed Public Works Contract;
 - 3. The Supplemental Terms and Conditions, if any;
 - 4. The General Terms and Conditions;
 - 5. The Technical Specifications (“Specifications”), Divisions 1-49: provisions in Division 1 shall take precedence over provisions of any other Division;
 - 6. Detail drawings;
 - 7. Drawings;
 - 8. All other sections in Division 0 not specifically identified herein by Section.
- B. Notwithstanding anything to the contrary above, with respect to any conflict or inconsistency between a Drawing or Detail Drawing and a Technical Specification, the provision imposing the more expensive duty or obligation on the Contractor shall take precedence.

1.3. CLARIFICATION OF DRAWINGS AND DETAIL DRAWINGS

- A. Where on any drawing a portion of the Work is drawn out and the remainder is indicated in outline, the drawn out parts shall apply also to other similar portions of the Work. Where ornament or other detail is indicated by starting only, such detail shall be continued throughout the courses or parts in which it occurs and shall apply to all other similar parts of the Work, unless otherwise indicated.
- B. With regard to drawings the following shall apply:
 - 1. Written dimensions shall be followed; drawings may not be to scale.
 - 2. Figure dimensions on drawings shall govern over scale dimensions; and detail drawings shall govern over general drawings.

ARTICLE 2: PORT

2.0. AUTHORITY

- A. Unless the Port, in writing, indicates otherwise, the authority to (1) commit to or bind Port to any Change Orders or change in Contract Work, Contract Price and/or Contract Time; or (2) sign the Contract or Change Orders rests solely in the Port Executive Director or his designee.

- B. The Port shall identify the Port's Project Representative and the Engineer in the Contract prior to Contract execution.
 - 1. In the event the Port's Project Representative is no longer assigned to the Contract, Port shall notify the Contractor in writing of the change providing the name of the new Port's Project Representative and effective date of the change.
- C. The Port's Project Representative shall have the authority to administer the Contract. Administration of the Contract by the Port's Project Representative includes but is not limited to:
 - 1. Receiving all correspondence and information from the Contractor;
 - 2. Issuing Field Directives;
 - 3. Issuing request for Change Proposals;
 - 4. Responding to Requests For Information;
 - 5. Reviewing the schedule of values, project schedules, submittals, testing and inspection reports, substitution requests, and other documentation submitted by the Contractor;
 - 6. Negotiating Change Proposals and Change Orders;
 - 7. Recommending Change Orders for approval by the Port Executive Director or his designee;
 - 8. Issuing decisions with respect to Requests for Change Orders and Claims;
 - 9. Processing payment requests submitted by the Contractor, and recommending payment;
 - 10. Monitoring the quality of the work, rejecting noncompliant work, and recommending acceptance of the work;
 - 11. Transmitting executed Change Orders, amendments, and other Contract correspondence to the Contractor, and
 - 12. Performing all other contract administrative functions.
- D. All correspondence, questions, and/or documentation shall be submitted to the Port's Project Representative.
- E. For the purposes of contract administration, the party identified as the Engineer in the technical specifications shall be the Port's Project Representative.
- F. The Port's Project Representative may designate Technical Representatives to perform functions under the Contract, such as review and/or inspection and acceptance of supplies, services, including construction, and other functions of a technical or administrative nature.

1. The Port's Project Representative will provide a written Notice of its designation to the Contractor. The designation letter will set forth the authority of the Technical Representatives under the Contract.
2. The Port's Project Representative may add to or modify in writing these designations from time to time.
3. The Port's Project Representative cannot grant a Technical Representative greater authority than the authority of the Port's Project Representative.

2.1. INFORMATION SUPPLIED BY PORT

- A. Unless otherwise specifically provided in the Contract, surveys and site information provided by Port are intended to describe the general physical characteristics of the Site. Port does not represent that this information is complete or sufficient for the Contractor's performance of the Work.
- B. Port shall furnish to the Contractor one digital and two (2) hard copies of the Contract Documents. The Contractor shall pay Port for any additional hard copies of Contract Documents.
- C. All drawings, models, and specifications furnished by Port are solely for use on this Contract and are not to be used by the Contractor on any other work or project.

2.2. WORK BY PORT OR SEPARATE CONTRACTORS

Port reserves the right to perform work not included in the Contract or to let other contracts in connection with this Project.

ARTICLE 3: CONTRACTOR

3.0. CONTRACTOR REPRESENTATIONS

The Contractor makes the following representations to Port:

- A. Before submission of its bid, the Contractor has:
 1. Carefully reviewed the Contract Documents, and visited and examined the Site;
 2. Become familiar with the general and local conditions in which the Work is to be performed, and satisfied itself as to the nature, location, character, quality and quantity of Contract Work, the labor, materials, equipment, goods, supplies, work, services and other items to be furnished and all other requirements of the Contract Documents, as well as the surface and reasonably ascertainable subsurface conditions and other matters that may be encountered at the Site or affect performance of the Contract Work or the cost or difficulty thereof;
 3. Become familiar with and satisfied itself as to the conditions bearing upon transportation, disposal, handling, and storage of materials; and
 4. Become familiar with and satisfied itself as to the availability of labor, water, electric power, and roads; and the uncertainties of traffic, weather, river stages,

tides, or similar physical conditions at the site. Any failure of the Contractor to take the action described in this provision or elsewhere in the Contract Documents will not relieve the Contractor from responsibility for estimating properly the difficulty and cost of successfully performing the Work, or for proceeding to successfully perform the Work without additional expense to Port;

- B. The Contract Price is reasonable compensation for the Work and the Contract Time is adequate for the performance of the Work as represented by the Contract, site visit, and the general conditions (including but not limited to weather, site, soil) known or reasonably anticipated for the Site;
- C. The Contractor is financially solvent, able to pay its debts as they mature, and possesses sufficient working capital to complete the Work and perform the Contractor's obligations required by the Contract; and
- D. The Contractor is able to furnish tools, material, supplies, equipment, and labor required to complete the Work and perform the obligations required by the Contract and has sufficient experience and competence to do so.

3.1. GENERAL DUTIES

- A. The Contractor shall give sufficient supervision to the Work, using its best skill and attention. The Contractor is on notice that Port will be relying on the accuracy, competence and completeness of the Contractor's work. The Contractor shall supervise and be solely responsible for the proper performance of the Work in accordance with the Contract, including the construction means, methods, techniques, sequences, procedures, and for coordination of all portions of the Work.
- B. Unless specified elsewhere in the Contract, the Contractor shall provide and pay for all labor, materials, equipment, tools, construction machinery, utilities, transportation, and other facilities and services (including federal and state tax, industrial insurance, social security liability and all other applicable taxes) necessary for the proper execution and completion of the Work.
- C. The Contractor shall also provide sufficient staffing and supervision to process Requests for Information, Change Proposals, Submittals, Change Orders, close out documentation, and to perform all other requirements of the Contract and all Work.
- D. The Contractor shall lay out its Work from baselines and benchmarks indicated in the Contract, if any, and shall be responsible for the accuracy of all field measurements and surveys used in the lay out.

3.2. DUTY TO INSPECT CONTRACT DOCUMENTS

- A. The Contractor shall carefully study and compare all Contract Documents and check the conditions, dimensions, and instructions as stated therein. Contractor will not be required to provide professional services which constitute the practice of architecture and engineering except to the extent provided for in the technical specifications and drawings.
- B. The Contractor shall immediately notify Port in writing of any:

1. Error, inconsistency, or omission in the Contract Documents that a reasonable contractor knew or through the exercise of reasonable diligence should have discovered under the same and similar circumstances;
 2. Requirement(s) in the Contract Documents that conflict with any local, state, and federal laws, regulations and/or permits, licenses, and easement conditions that a reasonable contractor knew or through the exercise of reasonable diligence should have discovered under the same and similar circumstances.
- C. The Contractor should not proceed with the work in question until the Contractor receives written direction from the Port's Project Representative.
- D. If the Contractor proceeds with the Work in question without written direction from the Port's Project Representative, the Contractor shall be responsible for any costs or damages associated with:
1. Fines or penalties;
 2. Demolition, tear out, removal, cleanup, remediation, or fixing the work in question; and
 3. Delay, disruption, and loss of productivity.

3.3. COMMUNICATIONS

- A. The Contractor must designate, in writing, its Contractor's Representative who is responsible for administering the Contract and has the authority to bind and obligate the Contractor in the performance of the Work. The Contractor's Representative shall be identified in the Contract.
- B. Communication with the Contractor shall be through the Contractor's Representative.
- C. The Contractor shall notify the Port immediately in writing if the Contractor's Representative is changed and identify the name of the new Contractor's Representative and effective date of the change.

3.4. CONTRACTOR'S SUPERVISION AND EMPLOYEES

- A. Contractor shall provide qualified and competent people to administer the Contract and perform all the Work.
- B. During performance of the Work the Contractor shall have supervisory personnel on-site and available to administer, manage and coordinate the Work. Port shall not be responsible for the acts or omissions of the supervisory personnel or their assistants.
- C. The Contractor shall at all times enforce good order among all persons furnishing labor or materials on-site and shall only employ workers skilled in the Work assigned. If requested by the Port's Project Representative, Contractor shall provide the Port's Project Representative with copies of licenses, registrations, and certifications.

1. Port shall have the right to require the Contractor to remove personnel from the Site that do not have the appropriate qualifications and experience to meet or uphold the requirements of the Contract. Port shall also have the right to order the Contractor to replace personnel who demonstrate unprofessional behavior.
2. Failure by Port to require removal of any Contractor personnel shall not be deemed an admission that any such personnel are satisfactory, nor shall such failure relieve the Contractor from any contractual responsibility.

3.5. CONTRACTOR'S DUTY WHEN PORT PERFORMS WORK ON-SITE

- A. The Contractor shall coordinate its Work with Port and other Port contractors and, at Port's request, participate in meetings for the purpose of coordinating the Contractor's construction schedule with those of other contractors at no additional cost to Port. If the contractors cannot resolve a conflict concerning access to the Site without impacting Contract Price, Contract Time, and any milestones in the Contract Documents, the Port's Project Representative shall issue written direction to resolve the conflict.
- B. The Contractor shall not cut, excavate, alter, impair, or otherwise engage in Work activity that inhibits the work of any other contractors without the prior written consent of Port.
- C. If any part of the Contractor's Work depends, for proper execution or results, upon the prior work of Port or any other contractor, the Contractor shall, before performing the affected Work, inspect and give prompt written Notice of any apparent discrepancies or defects in the prior work that renders it unsuitable for the reception of Contractor's Work. Contractor's failure to so inspect and to give such prompt Notice shall constitute acceptance of the prior work as fit for reception of its Work, except as to defects not then reasonably discovered.

3.6. SUBCONTRACTORS AND SUPPLIERS

- A. This Contract is between Port and the Contractor.
 1. The Contractor's subcontracting shall not create a contract between Port and the Subcontractor and Suppliers. Subcontractors and Suppliers are not incidental third-party beneficiaries to the Contract. The Subcontractor and Suppliers shall have no rights against Port by reason of its subcontract with the Contractor.
 2. The Contractor will be responsible for performing all Work as required by the Contract. The Contract has not been written with the intent of, and Port shall not be a party to, defining the division of work between the Contractor and its Subcontractors and Suppliers.
 3. The Contractor shall be responsible for all Work and material furnished, and no subcontract shall in any case release the Contractor of its obligations or liability under this Contract and the Performance and Payment Bond.

B. Selection of Subcontractors and Suppliers

1. Subcontractors and Suppliers shall be properly licensed, registered or certified, as applicable, and capable to perform the assigned Work.
2. If requested by Port, the Contractor shall provide documentation that the proposed Subcontractors and Suppliers are experienced and equipped to do the Work.
3. The Contractor shall require each Subcontractor and Supplier to comply with all provisions of this Contract. At the request of Subcontractors or Suppliers, Contractor shall make available for copying all Contract Documents.

C. Responsibility for Work of Subcontractors and Suppliers

The Contractor shall be responsible for the acts and omissions of Subcontractors and Suppliers. The Contractor shall also be responsible for the suitability of any materials, components, equipment or supplies furnished by a Subcontractor and/or Supplier irrespective of whether such were designated or approved by Port.

3.7. SCHEDULE OF WORKING HOURS

- A. Port and Contractor shall determine a mutually agreeable schedule of working hours to be used by Contractor during the performance of Work under the Contract. This schedule shall comply with all Contract requirements.
- B. The Contractor shall provide 48 hours advance written Notice of any intent to work outside of the mutually agreed schedule of working hours. Any Work performed outside mutually agreed working hours shall be performed without additional expense to Port, except as otherwise provided in the Contract Documents.

3.8. RECORD DOCUMENTS

- A. The Contractor shall keep a copy of the Contract Documents on the Site.
- B. The Contractor shall keep at the Site an accurate, readable, and orderly set of drawings and specifications, updated as the job progresses to show all approved changes, options, alternates, and all actual deviations from the original Contract Documents. This set of drawings and specifications shall be the Record Documents. (“Record Documents”).
 1. The Record Documents shall be maintained in hard copy.
 2. In addition to all approved changes, options, alternates, and all actual deviations from the original Contract Documents, the Record Documents shall be marked as follows:
 - a. Record all materials used where options, alternates and/or change orders were indicated, specified and/or authorized;
 - b. Accurate measurements referenced as required by the technical specifications shall be recorded to show the exact location and changes in direction of all underground services and utilities, as well as their depth below finished grade;

- c. Update the Record Documents with information about each item of capital equipment or other fixed asset installed, including type of equipment, make, model, serial number, and acquisition cost;
 - d. Update the Record Documents identifying each item of capital equipment or other fixed asset removed from the Project, including type of equipment or fixed asset, make, model, serial number and description of location from which it was removed; and
 - e. Record all other requirements as specified in the Technical Specifications.
- C. The Record Documents shall be kept up-to-date and be available for review by Port at all times, including but not limited to at each job progress meeting. Failure to have the Record Documents up-to-date shall be sufficient reason for Port to withhold payment in accordance with paragraph 7.2, Payments Withheld, until all such information is recorded.
- D. Record Documents may be used to assist Port to verify the appropriate progress payment.

3.9. COST RECORDS

- A. The Contractor, Subcontractors, and Suppliers shall maintain Project cost records by cost codes and shall segregate and separately record at the time incurred all costs (1) directly associated with each work activity and (2) directly or indirectly resulting from any event or condition for which the Contractor seeks an adjustment in the Contract Price, Contract Time, and/or damages.
- 1. Any costs claimed to result from any such event or condition, including, but not limited to, delay and impact costs, acceleration costs, loss of productivity or efficiency, and increased or extended overhead shall be recorded at the time incurred and be fairly and reasonably allocated to each such event or condition and to other causes of such costs.
 - 2. Port shall be provided with a detailed description of all such costs and the basis of allocation. The Contractor, Subcontractors, and Suppliers shall maintain a monthly summary of all costs and shall make all underlying cost records and monthly summary of costs available for review, inspection, and copying by Port upon request.
 - 3. Any Work performed for which the Contractor intends to seek an adjustment in Contract Price and/or Contract Time shall be recorded on the same day the Work is performed and kept separate so as to distinguish it from Contract Work.

3.10. MAINTENANCE AND INSPECTION OF DOCUMENTS

- A. All Contractor's, Subcontractors', and Suppliers' documents and records relating to the Contract shall be open to inspection, audit, and/or copying by Port or its designee:
- 1. During the Contract Time; and

2. For a period of not less than six years after the date of Final Acceptance of the Contract (“Preservation Period”); or if any Claim, audit or dispute, in connection with, or related to this Contract is initiated, all documents shall be retained until such Claim, audit or dispute involving the records is resolved or completed, whichever occurs later.
- B. The Contractor shall also guarantee that all Subcontractor and Supplier documents shall be retained and open to similar inspection, audit and/or copying during the Contract Time and also the Preservation Period. The Contractor, Subcontractor, and Supplier shall use its best efforts to cooperate with the inspection, auditing, and/or copying.
 - C. Inspection, audit, and/or copying of all documents described herein, may be performed by Port or its designee at any time with not less than seven (7) days’ Notice. Provided however, if an audit or inspection is to be commenced more than sixty (60) days after the Final Acceptance date of the Contract, the Contractor will be given twenty (20) days’ Notice of the date of the audit.
 - D. The Contractor, Subcontractors, and Suppliers shall provide adequate facilities, acceptable to Port, for inspection, auditing, and/or copying during normal business hours.
 - E. If the Contractor is formally dissolved, assigns or otherwise divests itself of its legal capacity under this Contract, then it shall immediately notify Port and preserve such records, at its expense, as directed by Port.
 - F. The Contractor, Subcontractor, and Supplier, shall be subject to audit at any time with respect to this Contract. Failure to maintain and retain sufficient records to allow Port to verify all costs or damages or failure to permit Port access to the books and records shall constitute a waiver of the rights of the Contractor Subcontractor and Supplier to Claim or be compensated for any damages, additional time or money under this Contract.
 - G. At a minimum, the following documents, including the machine readable electronic versions, shall be available for inspection, audits, and/or copying:
 1. Daily time sheets and all daily reports, Supervisor’s reports, and inspection reports;
 2. Collective bargaining agreements;
 3. Insurance, welfare, and benefits records;
 4. Payroll registers;
 5. Earnings records;
 6. All tax forms, including payroll taxes;
 7. Material invoices and requisitions;
 8. Material cost distribution worksheet;

9. Equipment records (list of Contractor's, Subcontractors', and Suppliers' equipment, rates, etc.);
10. Contracts, purchase orders and agreements between the Contractor and each Subcontractor and Supplier;
11. Subcontractors' and Suppliers' payment certificates;
12. Correspondence, including email, with Subcontractors and/or Suppliers;
13. All meeting notes by and between Contractor, Subcontractors, Suppliers and/or any third parties related to the Project;
14. Canceled checks (payroll and vendors);
15. Job cost reports, including monthly totals;
16. Job payroll ledger;
17. Certified payrolls;
18. General ledger;
19. Cash disbursements journal;
20. Escrow bid documents, take off sheets, and calculations used to prepare the bid and/or quotes;
21. Take off sheets, calculations, quotes, other financial data to support change proposals, request for change order and/or claims;
22. Financial statements for all years during the Contract Time. In addition, Port may require, if it deems appropriate, additional financial statements for 3 years preceding execution of the Contract and 6 years following Final Acceptance of the Contract;
23. Depreciation records on all Contractor's, Subcontractor's, and Supplier's equipment, whether these records are maintained by the Contractor, Subcontractors, and Suppliers involved, its accountant, or others;
24. If a source other than depreciation records is used to develop costs for the Contractor's internal purposes in establishing the actual cost of owning and operating equipment, all such other source documents;
25. All documents which relate to each and every Claim together with all documents which support the amount of damages as to each Claim;
26. Worksheets or software used to prepare the Claim establishing the cost components for items of the Claim including but not limited to labor, benefits and insurance, materials, equipment, Subcontractors, Suppliers, all documents which establish time periods, individuals involved, the hours for the individuals, and the rates for the individuals;

27. Worksheets, software, and all other documents used (a) by the Contractor to prepare its bid and schedule(s) and/or (b) to prepare quotes and bids to the Contractor;
28. All schedule documents, including electronic versions, planned resource codes, or schedules and summaries;
29. All submittals; and,
30. All other documents, including email, related to the Project, Claims, or Change Orders.

3.11. MAINTENANCE AND SITE CLEANUP

- A. The Contractor shall at all times keep the Site, access points, and public rights-of-way free from accumulation of dirt, mud, waste materials or rubbish caused by the Contractor or Subcontractors. At the completion of the Contract Work, the Contractor shall remove and lawfully dispose of all its dirt, mud, waste materials, rubbish, tools, scaffolding and surplus or partly used materials from the Site and shall leave the Site broom clean unless some stricter standard is specified in the Contract.
- B. The Contractor shall obey all applicable laws and regulations relating to the storage, use, and disposal of Hazardous Materials. The Contractor shall promptly notify Port of all Contractor or Subcontractor caused spills or releases of Hazardous Materials, and pay the cost to promptly clean up all such spills or releases and any associated fines or penalties. The Contractor shall maintain documentation of the clean-up and disposal all Contractor or Subcontractor caused spills or releases of Hazardous Materials.
- C. In case of a dispute over clean up, Port may, after written Notice to the Contractor, sweep surfaces or remove the dirt, mud, waste materials, rubbish, or hazardous materials and charge all reasonable costs of such work to the Contractor. Port may charge the Contractor or deduct such costs from payments otherwise due the Contractor pending a resolution of the dispute or exercise its rights under the Performance and Payment Bond. If there are insufficient funds remaining, excluding retention, the Contractor shall pay Port for the costs associated with maintenance and site cleaning.

3.12. PROTECTION OF EXISTING STRUCTURES, EQUIPMENT, VEGETATION, UTILITIES, AND IMPROVEMENTS

- A. Contractor shall protect from damage all existing structures, curbs, gutters, sidewalks, equipment, improvements, utilities, trees, and vegetation not shown in the Contract Documents to be removed or modified at or near the Site. Contractor shall repair, at no cost to Port, any such damage resulting from failure to comply with the requirements of the Contract or failure to exercise reasonable care in performing the Work. If Contractor fails or refuses to repair the damage promptly, Port may have the necessary work performed and deduct or charge the cost to Contractor or exercise its rights under the Performance and Payment Bond. If there are insufficient funds remaining, excluding retention, the Contractor shall pay Port for the costs associated with protection and repairing the damages.

3.13. PERMITS, LAWS AND REGULATIONS

- A. Except those permits, easements, and variances specified in the Contract as having been previously obtained by Port, all permits, licenses, easements and variances necessary for the execution of the Work shall be secured and paid for by the Contractor. The Contractor shall identify, apply for, and pay for such permits and licenses at the earliest possible time so as to avoid any delay to the Contract Work arising from the permitting and/or licensing process. No actions taken by Port to aid the Contractor in securing any permit or license shall relieve the Contractor of any obligations to secure any such permit or license.
- B. The Contractor shall maintain all stamped permit sets of documents at the Site during construction, in good condition and as required by local ordinances.
- C. The Contractor shall perform all work hereunder in full compliance with local, state and federal laws, ordinances, resolutions, regulations, and all applicable Port Policies and Procedures and with permit, license, easement, and variance conditions pertaining to the conduct of the Work.
- D. Washington State Prevailing Wage Act. Contractor shall be required to comply with the Washington State Prevailing Wage Act. Contractor certifies that all laborers, workers and/or mechanics shall not be paid less than the required hourly minimum rate of wage.
- E. The Contractor shall defend, indemnify, and hold Port, its elected officials, officers, agents and employees harmless from any assessment of fines, penalties, or damages arising from violations of the same by the Contractor or Subcontractors. The Contractor shall pay and provide proof of payment for any assessments of fines, penalties or damages. The Contractor shall cooperate with all governmental entities regarding inspection of the Work and compliance with such requirements.
- F. Taxes. The Contractor is required to pay all applicable taxes. No adjustment will be made in the amount to be paid by Port under the Contract because of any change in law or regulations covering any applicable taxes, or because of any misunderstanding by the Contractor as to its liability for or the amount of any taxes.

3.14. PATENTS AND ROYALTIES

- A. The costs or fees relating to royalties or claims for any patented invention, article, process or method that may be used upon or in a manner connected with the Work under this Contract or with the use of completed Work by Port shall be paid by the Contractor. The Contractor and its sureties shall protect and hold Port, and its elected officials, officers, agents and employees, harmless against any and all demands made for such fees or claims brought or made by or on behalf of the holder of any invention or patent. Before final payment is made on the account of this Contract, the Contractor shall, if requested by Port, furnish acceptable proof of a proper release from all such fees or claims.
- B. Should the Contractor, its agent, representatives or employees, or any of them, be enjoined from furnishing or using any invention, article, material or appliances supplied or required to be supplied or used under the Contract, the Contractor shall promptly notify Port of the Contractor's intent to substitute other articles, materials

or appliances in lieu thereof which are of equal efficiency, quality, finish, suitability, and market value, and satisfactory in all respects to Port. In the event Port elects, in lieu of such substitution, to have supplied and to retain and use any such invention, article, material or appliances as may be required to be supplied by the Contract, the Contractor shall pay all royalties and secure such valid licenses as may be requisite and necessary for Port, its elected officials, officers, agents and employees, or any of them to use such invention, article, material or appliance without being disturbed or in any way interfered with by any proceeding in law or equity on account thereof. Should the Contractor neglect or refuse to make the substitution promptly or to pay such royalties and secure such licenses as may be necessary, then in that event Port shall have the right to make such substitution or Port may pay such royalties and secure such licenses and charge the Contractor, even though final payment under the Contract may have been made.

3.15. CONTRACTOR'S CERTIFICATION

A. Conflict of Interest

The Contractor certifies (and shall require each Subcontractor to certify) that it has no direct or indirect pecuniary or proprietary interest, and that it shall not acquire any such interest, which conflicts in any manner or degree with the Work, services or materials required to be performed and/or provided under this Contract and that it shall not employ any person or agent having any such interest. In the event that the Contractor or its agents, employees or representatives acquires such a conflict of interest, the Contractor shall immediately disclose such interest to Port and take action immediately to eliminate the conflict or to withdraw from this Contract, as Port may require.

B. Contingent Fees and Gratuities

The Contractor, by entering into this Contract with Port to perform or provide Work, services or materials, has thereby covenanted:

1. That no person or selling agency except bona fide employees or designated agents or representatives of the Contractor has been or will be employed or retained to solicit or secure this Contract with an agreement or understanding that a commission, percentage, brokerage, or contingent fee may be paid; and,
2. That no gratuities, in the form of entertainment, gifts or otherwise, have been or will be offered or given by the Contractor or any of its agents, employees or representatives, to any official member or employee of Port or other governmental agency with a view toward securing this Contract or securing favorable treatment with respect to the awarding or amending thereof, or the making of any determination with respect to the performance of this Contract. The Contractor certifies that it has not made any contributions to any person or entity as a condition of doing business with Port and it has disclosed to Port all attempts by any person to solicit such payments.

3.16. DEVIATION FROM CONTRACT

- A. The Contractor shall not make an alteration, variation, addition, deviation, or omission from the requirements of the Contract without the prior written consent of the Port's Project Representative.
- B. Any alteration, variation, addition, deviation, or omission by the Contractor shall not result in any extra compensation or extension of time.
- C. Port shall have the right to treat any alteration, variation, addition, deviation, or omission from the requirements of the Contract as a contract breach if prior written consent is not obtained from the Port's Project Representative.

3.17. OPERATIONS, MATERIAL HANDLING, AND STORAGE AREAS**A. Temporary Buildings and Utilities**

Temporary buildings (including storage sheds, shops, and offices) and utilities may be erected by Contractor on the Site only with the consent of Port and without expense to Port. The temporary buildings and utilities shall remain the property of Contractor and shall be removed by the Contractor at its expense upon completion of the Work.

B. Disposal/Removal of Materials

The Contractor shall be responsible for compliance with all laws governing the storage and ultimate disposal of all materials and components. The Contractor shall provide Port with a copy of all manifests and receipts evidencing proper disposal when required by Port or applicable law.

C. Protection and Care of Contractor's Materials and Equipment

The Contractor shall be responsible for the proper care and protection of its materials and equipment delivered to the Site. Materials and equipment may be stored on the Site at the Contractor's own risk and with prior written approval from Port. When the Contractor uses any portion of the Site as a shop, the Contractor shall be responsible for any repairs, patching, or cleaning arising from such use and for obtaining any necessary permits to establish such shop or temporary storage facilities.

3.18. CONTRACTOR'S OVERALL RESPONSIBILITY FOR PROTECTION OF WORK, PROPERTY, AND PERSONS

- A. The Contractor shall be responsible for conditions of the Site, including safety of all persons and property, during performance of the Work. The Contractor shall maintain the Site and perform the Work in a manner which meets all statutory and common law requirements or other specific contractual requirements for the provision of a safe place to work and which adequately protects the safety of all persons and property on or near the Site. This obligation shall apply continuously and shall not be limited to normal working hours. Port's inspection of the Work or presence at the Site does not and shall not be construed to include review of the adequacy of the Contractor's safety measures in, on or near the site of the Work.

- B. The Contractor shall be responsible for initiating, maintaining and supervising all safety precautions and programs, including adequate safety training, in connection with the Work. The Contractor shall comply with all applicable laws, ordinances, rules, regulations and lawful orders of any public authority bearing on the safety of persons or property or their protection from damage, injury or loss.
- C. The Contractor shall protect and be responsible for any damage or loss to the Work or to the materials and equipment associated with the Work until the date of Substantial Completion. The Contractor remains responsible for any damage or loss caused directly or indirectly by the acts or omissions of the Contractor, Subcontractors, Suppliers, or third parties authorized or allowed on the Site by the Contractor until Final Acceptance.
- D. The Contractor shall also be solely and completely responsible for damages arising from the Work that affect property adjacent to the Site.
- E. The Contractor shall repair or replace without cost to Port any damage or loss that may occur, except damages or loss solely caused by the negligent acts or omissions of Port.
- F. The Contractor shall erect and maintain adequate steel plates, signs, fencing, barricades, lights or security measures and persons to protect the Work until the Port's Project Representative authorizes in writing the removal of signs, fencing, barricades, lights or security measures.

3.19. PROTECTION OF PERSONS

- A. The Contractor shall take all reasonable precautions for the safety of all employees working on this Contract and all other persons who may be affected by such Work. The Contractor shall designate a responsible member of its organization at the Site whose duty shall be to manage and coordinate the safety programs and to prevent accidents of the Contractor and Subcontractors.
- B. Except as otherwise stated in the Contract, if the Contractor encounters, on the Site, material reasonably believed to be Hazardous Material that Contractor shall immediately stop work in the area affected and give Notice of the condition to Port. Work in the affected area shall not be resumed without written direction by Port.
- C. The Contractor shall maintain in a reasonable number of conspicuous and accessible places at the Site all materials necessary for giving first aid to the injured. The Contractor shall establish, publish and make known to all employees procedures for ensuring immediate removal to a hospital or a doctor's care, of persons who may have been injured on the Site. Employees shall not be permitted to work on the Site before the Contractor has: (1) provided all materials necessary for giving first aid at the Site; and (2) established and made known procedures for removal of injured persons to a hospital or doctor's care. The Contractor shall ensure that at least one of its employees on site has adequate training in first aid.
- D. In order to protect the lives and health of persons performing work under this Contract, the Contractor shall comply with the Federal Occupational Safety and Health Act of 1970 (OSHA), including all revisions, amendments and regulations issued thereunder, and the provisions of the Washington Industrial Safety Act of

1973 (WISHA), including all revisions, amendments and regulations issued thereunder by the Washington State Department of Labor and Industries. The WISHA regulations shall apply, without limitation, to all excavation, tunneling, trenching and ditching operations. In case of conflict between any such requirements, the more stringent regulation or requirement shall apply. There is no acceptable deviation from these safety requirements, regardless of practice in the construction industry. Any violation of OSHA, WISHA or other safety requirements applicable to the work may be considered a breach of this Contract.

3.20. SAFETY PROGRAM

- A. The Contractor shall prepare and provide to Port a written site specific “Safety Program” demonstrating the methods by which all applicable safety requirements of this Contract will be met. The Contractor shall ensure its Subcontractors and Suppliers have a written “Safety Program” or formally adopt the Contractor’s site specific “Safety Program.” The Contractor shall designate a Safety Officer who shall be responsible for proper implementation of the “Safety Program.” The Contractor shall submit a copy of its “Safety Program” and the Subcontractor’s “Safety Program” to Port within fourteen (14) days after the Contractor signs the Contract. Port’s review of such programs shall not be deemed to constitute approval or acceptance thereof and shall not relieve or diminish the Contractor’s sole responsibility for Site safety.
- B. The Contractor shall conduct a weekly safety meeting with all Subcontractors and others on the Site performing Work hereunder to discuss general and specific safety matters. The Contractor shall provide upon request, notice of each meeting to Port. At Port’s request the Contractor shall provide Port with a record of each meeting, including a sheet on which each attendee signed in and a list of the matters discussed.

3.21. STORAGE OF CONTRACTOR’S PROPERTY

The Contractor’s tools and equipment and materials to be incorporated into the Project may be stored on the Site but all such storage shall be subject to the requirements of the Contract. Any repairs, patching or cleaning of the Site that may be necessary to restore the Site to its previous condition due to storage of the Contractor’s materials, tools or equipment, or other aspects of the Contractor’s Work, shall be the responsibility of the Contractor.

3.22. ARCHAEOLOGICAL AND HISTORICAL PRESERVATION

The Contractor shall comply fully with the requirements set forth in Chapter 27.53 RCW entitled Archaeological Sites and Resources. The Contractor shall immediately notify the Port’s Project Representative if any artifacts, skeletal remains or other archaeological resources (as defined under RCW 27.53.040 now and as hereinafter amended) are unearthed during excavation or otherwise discovered on the site of the work. If directed by the Port’s Project Representative, the Contractor shall immediately suspend any construction activity, which, in the opinion of the Port’s Project Representative, would be in violation of Chapter 27.53 RCW. The suspension of Work shall remain in effect until permission to proceed has been obtained by the Port’s Project Representative from the State Historic Preservation Officer or private landowner, as applicable. The Contractor

shall comply fully with the cultural resource protection MOU between the Port and the Confederate Tribes of the Umatilla Indian Reservation.

3.23. WATER POLLUTION CONTROL REQUIREMENTS

The Contractor shall comply with and be liable for all penalties, damages and violations under Chapter 90.48 RCW in the performance of this work. By submitting a Bid for and entering into this Contract, the Contractor has thereby assured Port that the Contractor has knowledge of, understands, and will comply with the provisions and requirements of Chapter 90.48 RCW, including any regulations issued pursuant thereto. The Contractor shall also perform its work in compliance with water pollution control requirements as may be set forth in this Contract and as may be a part of any permit or other authorization issued or obtained for this Contract.

3.24. EASEMENTS

- A. If the Contractor makes arrangements for use of additional public and/or private property, the Contractor, prior to using such property, shall provide the Port's Project Representative with written permission of the landowner, or duly authorized agent of such landowner, for such use. Upon completion of use of such property, the Contractor shall provide the Port's Project Representative with a written release signed by such landowner or authorized agent therefore stating that the owner has no claims whatsoever against Port on account of the Contractor's use of such property. Such release shall be on the form provided by the Port.
- B. The Contractor shall save Port, its elected officials, officers, agents and employees harmless from all suits and legal proceedings of every kind and description that might result from use of or damage to rights of way and public and/or private property by the Contractor. The Contractor shall comply with all laws, rules, regulations, ordinances, resolutions or directives relating to its use of public rights or way, streets or highways; and its use of same shall not disturb the rights and property of adjacent landowners.

ARTICLE 4: ADMINISTRATION OF THE CONTRACT

4.0. TIME OF ESSENCE

All time requirements set forth in the Contract Documents are of the essence.

4.1. WORK PROGRESS

- A. The Contractor shall be required to:
 - 1. Prosecute the Work diligently with adequate forces;
 - 2. Plan, coordinate, and layout the Work in advance so as to avoid delay;
 - 3. Achieve Substantial Completion of the Work and Final Acceptance in accordance with the requirements of Contract Documents; and,

4. Complete all Contract close out requirements in accordance with all applicable Contract requirements within the time period established by Port in the Certificate of Substantial Completion.

4.2. SCHEDULE OF VALUES

- A. Unless otherwise specified, within fourteen (14) days after the date of Contract Execution, the Contractor shall submit to Port a detailed Schedule of Values that identifies the various activities of the Contract Work and their values and quantities, including the overhead and profit for each activity. The Contractor warrants that the values identified in its Schedule of Values accurately reflect the value of each work activity. The Schedule of Values shall be used as a basis for calculating all Progress Payments. Payment for Contract Work shall be made only for and in accordance with those activities identified in the Schedule of Values.
- B. The Contractor shall not be entitled to, nor shall Port be required to make, payment for any Contract Work until the Schedule of Values has been accepted in writing by Port. Such acceptance shall not be unreasonably withheld.
- C. The Port shall review and accept the Schedule of Values or provide the Contractor with a written explanation of why the Schedule of Values was not acceptable. Port shall use reasonable efforts to review the Schedule of Values within thirty (30) days of Port's receipt of the Contractor's submittal of its Schedule of Values. Port's acceptance of the Schedule of Values shall not relieve the Contractor from its sole responsibility for the accuracy of the Schedule of Values and its compliance with all Contract requirements. The Contractor shall revise the Schedule of Values as necessary to accurately reflect Change Orders.
- D. Each Application For Payment shall include a current status of the Schedule of Values. No Application For Payment will be considered until the current status of the Schedule of Values has been submitted and accepted.
- E. The activities which the Contractor identifies within its Schedule of Values, shall be specifically referenced within, and conform and be consistent with the activities set forth within the Project Schedule.

4.3. PROJECT SCHEDULE

- A. Unless otherwise specified, within fourteen (14) days after the date of Contract Execution, the Contractor shall submit to Port a Project Schedule. The Project Schedule shall show the sequence in which the Contractor proposes to perform the Work, indicate the Critical Path, identify the dates on which the Contractor proposes to start and finish the scheduled activities of the Contract Work, indicate Substantial Completion within the Contract Time, indicate a date for Final Acceptance, and meet all the requirements as maybe set forth more particularly in the Technical Specifications on Project Schedule.
- B. The Project Schedule shall be prepared in the format as specified in the Technical Specifications.
- C. Within thirty (30) days of Port's receipt of the Contractor's submittal of its Project Schedule or unless stated elsewhere in the Contract, Port shall review the Project

Schedule and provide the Contractor with written comments. Port will review the Project Schedule only to determine whether the Project Schedule meets the requirements in the Technical Specifications on Project Schedule. To the extent the Project Schedule does not meet such Technical Specifications, the Contractor shall revise the Project Schedule to make it compliant.

- D. By reviewing the Project Schedule and providing written comments, Port is not approving or adopting the Contractor's plan, schedule, means, methods, techniques, sequences, or procedures required to perform the Work. Review and comment by Port of the Project Schedule shall not relieve the Contractor from the sole responsibility for the accuracy of a Project Schedule, and its compliance with all Contract requirements, and its responsibility to meet all required Contract completion dates. Failure by Port to indicate items on the Project Schedule that do not conform with the Contract requirements shall not alter or waive the Contract requirements or relieve the Contractor from complying with all Contract requirements.
- E. The Contractor shall not be entitled to, nor shall Port be required to make payment for any Contract Work until the Project Schedule complies with all Contract requirements.
- F. The Contractor shall schedule the Contract Work so that the Contract Work is completed within the Contract Time. Float in the project Schedule shall be defined as the period of time measured by the number of days each non-critical path activity may be delayed before it and its succeeding activities become part of the Critical Path. Contractor and Owner may both utilize float to offset delays to the Project Work.
- G. The Contractor shall regularly enter the actual progress of the Work and Contract Time extensions, if any, approved by Port on the Project Schedule. Updated Project Schedules shall reflect actual progress and completion within the Contract Time and shall be provided to Port with each Application for Payment in format(s) as required by the Contract. Applications for Progress Payments will not be considered by Port and the Contractor will not be paid until the Contractor complies with these requirements. The updated Project Schedule shall be used to assist Port in verifying the appropriate payment.
- H. If, in the opinion of Port, the Contractor falls behind in its progress of the Work due to acts or omissions of the Contractor, Subcontractors, and Suppliers, the Contractor shall take all necessary steps to improve its progress and bring its progress back in-line with the accepted Project Schedule, without additional cost to Port. In this circumstance the Contractor shall, as necessary, increase the number of shifts, overtime operations, and/or days of work, both on and off the Site, and submit for acceptance any supplementary schedule or schedules as Port deems necessary to demonstrate how the accepted rate of progress will be regained. Failure of the Contractor to comply with the requirements under these provisions shall be grounds for a determination by Port that the Contractor is not prosecuting the Work with sufficient diligence to ensure completion within the time specified in the Contract. Upon making this determination, Port may pursue any right it has under the law or the Contract, including but not limited to default termination.

4.4. SUBMITTALS

- A. Submittals include shop drawings, setting and erection drawings, schedules of materials, product data, samples, certificates and other information prepared for the Work by the Contractor or a Subcontractor as set forth in the Technical Specifications (Submittals). The Contractor shall perform no portion of the Work requiring Submittals until the Submittals have been reviewed and returned by Port with one of the following annotations: (1) no exceptions taken or (2) note markings.
- B. Before furnishing the Submittals to Port, the Contractor shall: (1) review all Contractor and Subcontractor Submittals for accuracy, completeness, and compliance with the Contract; (2) coordinate all Submittals with all Contract Work by other trades and with field measurements; and (3) indicate approval on the Submittals as a representation that it has complied with its obligation to review and coordinate Submittals. Where required by law or by the Contract, Submittals shall be stamped by an appropriate licensed professional. Submittals lacking required stamps or evidence of Contractor review and approval will be returned without review by Port for resubmission. Submittals shall be sequentially numbered.
- C. When submitting information, the Contractor shall identify and state reasons for any alteration, variation, addition, deviation, or omission from the Contract. The Contractor shall not perform work that alters, varies, adds to, deviates from, or omits Work without prior specific written acceptance by Port.
- D. The Contractor shall provide Submittals with reasonable promptness and in such sequence as to facilitate the timely completion of the Contract. The Contractor shall prepare and keep current, for review by Port, a schedule of Submittals which is coordinated with the Contractor's Project Schedule and allows Port reasonable time for review.
- E. Port shall review the Contractor's Submittals and respond in writing with reasonable promptness so as not to unreasonably delay the progress of the Work. Unless otherwise agreed, and except for complex Submittals representing major portions of the Work, such as fire protection and aluminum framed glazing systems, no delay to the Contractor's Work shall be attributable to the failure by Port to respond to a Submittal until fourteen (14) Calendar days after the Submittal is received by Port, and twenty-one Calendar days after a complex Submittal is received by the Port and then only if failure by Port to respond is unreasonable and affects the Contract completion date.
- F. If the Contractor is required to resubmit a Submittal, any revisions on resubmittals shall be specifically identified in writing and the resubmitted Submittal shall be sequentially alpha denoted (for example: 22A followed by 22B, etc.) and note revisions in numerical order. The cost of the review of the initial Submittal and the first revised Submittal shall be borne by Port. The costs of all additional revised Submittals shall be charged to the Contractor. The cost of review shall include, without limitation, administrative, design, and engineering activities directly related to review of Submittals. Port may deduct these costs from any amounts due the Contractor.

- G. The Port shall review the Contractor's Submittals only for conformance with the design of the Work and compliance with the Contract. Review of the Submittals are not conducted to verify the accuracy of dimensions, quantities, or calculations, the performance of materials, systems, or equipment, or construction means, methods, techniques, sequences, or procedures, all of which remain the Contractor's responsibility. Failure by Port to take exception to a Submittal shall not relieve the Contractor from any duty, including its responsibility for errors or omissions in Submittals, its duty to make Submittals and duty to perform the Work according to the requirements of the Contract. Port's review of a Submittal shall not alter or waive the requirements of the Contract unless Port has issued prior written approval of such change or alteration of the Contract requirements.
- H. The Contractor's failure to identify any error, deviation, or omission and subsequent acceptance of the Submittal by Port shall not relieve the Contractor from complying with the Contract requirements.

4.5. REQUESTS FOR INFORMATION

- A. If the Contractor determines that some portion of the drawings, specifications or other Contract Documents require clarification or interpretation by Port because of an apparent error, inconsistency, omission, or lack of clarity in the Contract, the Contractor shall promptly submit a Request For Information ("RFI") and, unless otherwise directed, shall not proceed with the affected Work until Port has responded to the RFI. The Contractor shall plan its work in an efficient manner so as to allow for timely responses to RFIs.
- B. RFIs shall only be submitted by the Contractor on a RFI Form provided by Port or in a form acceptable to Port. The Contractor shall clearly and concisely set forth the issue for which clarification or interpretation is sought and why a response is needed by Port. In the RFI the Contractor shall set forth its own interpretation or understanding of the requirement along with reasons why it reached such an understanding.
- C. Port will review RFIs to determine whether they meet the requirements identified above in paragraph B to qualify as an RFI. If Port determines that the document is not an RFI it will be returned to the Contractor unreviewed as to content. When appropriate the Contractor may resubmit the RFI on the proper form, with all required information and in the proper manner.
- D. Port shall respond in writing with reasonable promptness to Contractor's RFI.
 - 1. At the request of the Port's Project Representative, the Contractor shall prioritize its RFIs, identify a date by which the Contractor prefers the RFI be answered, and reasons for such priority.
 - 2. If the Contractor submits a RFI on an activity less than thirty (30) days prior to the commencement of that activity, the Contractor shall not be entitled to any time extension or adjustment in Contract Price due to the time it takes Port to respond to the RFI provided that Port responds within fifteen (15) days. No delay to the Contractor's work or damages to the Contractor shall be attributable to the failure by Port to respond to the RFI until fifteen (15) days after Port's receipt of

the RFI, and then only if the failure by Port to respond is unreasonable and affects the Contract completion date.

- E. Port's response to a RFI by itself shall not be considered a change to the Contract requirements. However, Port's response may be accompanied by a Request for Change Proposal when a change is recognized. If no such indication is provided, to the extent the Contractor believes that Port's response to the RFI constitutes changed work impacting Contract Price or Contract Time, the Contractor shall submit a Contractor's Request For Change Order to Port in accordance with Articles 5, Changes to the Contract.

4.6. TESTS, INSPECTIONS, AND ACCESS TO THE WORK

- A. Contractor shall be responsible for inspection and quality assurance of all its Work and all Work performed by any Subcontractor. The Contractor shall document and maintain an adequate testing and inspection program and perform such tests and inspections as are necessary or required to ensure that the Work conforms to the requirements of the Contract. The Contractor shall maintain all documentation related to testing and inspection and make such documentation available to Port at its request. Unless otherwise provided, Contractor shall arrange for such tests, inspections, and approvals with an independent testing laboratory or entity acceptable to Port, or with the appropriate public authority. If any governmental, regulatory, or permitting authority requires any portion of the Work to be inspected, tested, or approved, the Contractor shall arrange for and cooperate with all such inspections, tests, and approvals so as not to delay completion of the Contract Work. The Contractor shall bear all related costs of tests, inspections, and approvals. The Contractor shall give Port at least three (3) days' Notice of: (1) when the work is ready to be tested and inspected and (2) when and where tests and inspections are to be made. Contractor shall maintain complete inspection records and make them available to Port upon request.
- B. The Contractor shall cooperate with Port in the performance of any tests and inspections of the Work. The Contractor has the duty to coordinate all tests and inspections in a manner, which does not negatively impact Contractor's compliance with the Contract.
- C. If any Work required to be inspected, tested, or approved is covered without such inspection, testing or approval being obtained, it must, if requested by Port, be uncovered for observation, and such uncovering shall be at Contractor's expense.
- D. Upon request by Port any Work, not otherwise required to be inspected or tested, shall be uncovered by the Contractor. If the Work is found to comply with the Contract or if any non-compliance was not caused by the Contractor, Subcontractor, or Supplier, Port will (1) pay the costs of testing and inspection; (2) pay the costs associated with the uncovering and recovering of the Work; and, (3) adjust the Contract Time to the extent the inspection and repair impacted the Project Schedule and delayed completion of the Work, otherwise the Contractor shall bear such costs as well as all costs of correction and the Contractor shall not be entitled to an adjustment in Contract Time.

- E. Port may, at any reasonable time and at its own cost, conduct inspections and tests as it deems necessary to ensure that the Work is in accordance with the Contract. Port shall promptly notify Contractor if an inspection or test reveals that the Work is not in accordance with the Contract. Port inspection and tests are for the sole benefit of Port and do not:
1. Constitute or imply acceptance;
 2. Relieve Contractor of responsibility for providing adequate quality control measures;
 3. Relieve Contractor of responsibility for risk of loss or damage to the Work, materials, or equipment;
 4. Relieve Contractor of its responsibility to comply with the requirements of the Contract; or,
 5. Impair Port's right to reject defective or nonconforming items, or to avail itself of any other remedy to which it may be entitled.
- F. Neither observations by an inspector retained by Port, the presence or absence of such inspector on the Site, nor inspections, tests, or approvals by others, shall relieve Contractor from any requirement of the Contract. Inspectors are not authorized to change any term or condition of the Contract.
- G. Contractor shall promptly furnish, without additional charge, all facilities, labor, material and equipment reasonably needed for performing such safe and convenient inspections and tests as may be required by Port. Port may charge Contractor any additional cost of inspection or testing when Work is not ready at the time specified by Contractor for inspection or testing, or when prior rejection makes reinspection or retest necessary. Port shall perform its inspections and tests in a manner that will cause no undue delay in the Work.

4.7. CORRECTION OF WORK OR DAMAGED PROPERTY

- A. If material, equipment, workmanship, or Work proposed for, or incorporated into the Work, does not meet the Contract requirements or fails to perform satisfactorily, Port shall have the right to reject such Work by giving the Contractor written Notice that such Work is either defective or non-conforming.
1. Port, at its option, shall require the Contractor, within a designated time period as set forth by Port, to either:
 - a. Promptly repair, replace or correct all Work not performed in accordance with the Contract at no cost to Port; or
 - b. Provide a suitable corrective action plan at no cost to Port.
 2. Once the corrective action plan is reviewed and returned by Port with the annotation "no exception taken" or "note markings" by Port, the Contractor shall implement the corrective action plan at its sole expense.

- a. Review and providing comments on the corrective action plan is not an acknowledgement by Port that such plan is adequate to remedy the defective or non-conforming work.
 - b. If the corrective action plan does not remedy the defective or non-conforming Work, the Contractor shall remain responsible for remedying the defective or non-conforming Work to Port's satisfaction.
3. The Contractor shall also be responsible for all repairs to or compensation for any Premises and Work damaged by the Contractor.
 4. Under no circumstances shall the Contractor be entitled to additional time or money for the correction of defective or non-conforming Work or for the repair of damaged property. Port shall not be responsible for any costs to prepare corrective action plans, correct work or repair damaged property.
- B. If the Contractor does not repair, replace or correct and/or remove defective or non-conforming Work or repair damaged property as required by Port, in manner and/or schedule, Port or Port's designee may repair, replace or correct and/or remove it and deduct the cost of such effort from any payment due the Contractor.
1. If the remaining payments due the Contractor are not sufficient to cover Port's cost of remedying the defective or non-conforming Work, the Contractor shall pay the difference to Port.
- C. The Contractor shall be liable for all damages and costs incurred by Port caused by the Contractor's or its Subcontractors' and Suppliers' defective or non-conforming work or workmanship, including but not limited to all special, incidental, or consequential damages incurred by Port. The Contractor agrees to indemnify, defend and hold Port, its elected officials, officers, agents and employees harmless from any personal injury or property damage caused by the Contractor or its Subcontractors defective or non-conforming Work or workmanship.

4.8. SUBSTITUTION OF PRODUCTS & PROCESSES

- A. Substitutions requested by the Contractor after Contract signing will be subject to Port's prior written acceptance and at Port's sole discretion.
- B. Substitution requests after Contract signing will be considered for the following reasons only:
1. A product becomes unavailable due to no fault of the Contractor.
 2. Subsequent information or changes indicate that the specified product will not perform as intended.
- C. Requests for substitution after Contract signing must specifically identify:
1. Material, equipment, and labor costs included in the Contractor's Bid associated with the original item to be substituted;

2. All costs for material, equipment, labor associated with the proposed substitution, including any impact costs;
 3. Proposed change to the Contract Price and/or Contract Time; and,
 4. Compatibility with or modification to other systems, parts, equipment or components of the Project and Contract Work.
- D. Contractor shall provide all documentation supporting its request as requested by Port.
- E. All costs of any redesign or modification to other systems, parts, equipment or components of the Project or Contract Work, which result from the substitution, shall be borne by the Contractor.
- F. When Port approves a substitution proposed by the Contractor, the Contractor shall guarantee the substituted article or materials to be equal to, or better than, those originally specified and shall be compatible with all other systems, parts, equipment or components of the Project and Contract Work. Port has the right to order an unaccepted, substituted article removed and replaced without additional cost to Port.
- G. Port has a right to a deductive Change Order if the substituted product or process is less costly than the contractually required product or process.
- H. If Port does not accept the substitution proposal the Contractor shall proceed, without delay or cost to Port, with the Contract Work as originally specified.
- I. Only one proposed product or system may be the subject of a requested substitution. The Contractor shall include with each request complete data substantiating compliance of the proposed substitution with Contract Documents.
- J. Products subject to substitution requirements will not be considered when they are indicated or implied on shop drawing or product data submittals.

ARTICLE 5: CHANGES TO THE CONTRACT

5.0. GENERAL

- A. No provisions of the Contract may be amended or modified except by written agreement signed by the Port.
- B. All Change Order work shall be performed in accordance with the original Contract requirements unless modified in writing by Port.
- C. Any written Field Directive, response to Request For Information, or other directive, direction, instruction, interpretation, or determination (hereinafter referred to as "Direction" for the purposes of Article 5), provided by Port is not considered a Change Order, a change to Contract requirements, and shall not constitute, in and of itself, entitlement to an adjustment in Contract Price and/or Contract Time.

- D. To the extent the Contractor believes it is entitled to any additional money or time for any reason the Contractor shall submit a Request For Change Order to Port as more fully described in Article 5, Changes to the Contract.
1. If the Contractor believes any of the following events entitles the Contractor or its Subcontractors or Suppliers to additional money or time, the Contractor must file a Request for Change Order in accordance with the requirements set forth in the Contract Documents.
 - a. Written Field Directive
 - b. Response to a request for information
 - c. Comments on a submittal
 - d. Differing Site Condition
 - e. Acceleration or constructive acceleration
 - f. Suspension of the Work
 - g. Delay, inconvenience, disruption of schedule, loss of efficiency or productivity
 - h. Port caused Stand-by
 - i. Force Majeure
 - j. Conflicts, ambiguities, inconsistencies, and/or problems arising from the Contract Documents
 - k. Any other directive or Direction, written or oral, from Port
 - l. Any other reason for which the Contractor believes it is entitled to additional money or time.
- E. The Contractor shall not be entitled to any change in the Contract Price and/or Contract Time under the following conditions or events:
1. They were reasonably foreseeable at the time the Contractor submitted its Bid;
 2. They were caused by the acts of the Contractor, Subcontractor and/or Supplier, including but not limited to the choice of means, methods, techniques, sequences, or procedures for the Work, failure to provide labor, materials or equipment in a timely manner, and failure to take reasonable steps to mitigate delays, disruptions, or conditions encountered.
- F. The Contract requirements for time and price impacts related to Change Orders are set forth in Article 6, Time and Price Adjustments.

5.1. CONTRACTOR'S REQUEST FOR A CHANGE ORDER**A. Notice of Intent to Submit a Request for Change Order.**

1. The Contractor shall provide the Port's Project Representative with the written Notice that the Contractor intends to submit a Request For Change Order no later than seven (7) days, except as specified below for Differing Site Conditions, after any direction, instruction, interpretation, determination by Port and/or the onset of any event or impact to the Project.
2. The Contractor shall include the following information in the Notice of Intent to Request a Change Order:
 - a. The date, circumstances, and source of the direction, instruction, interpretation, determination by Port and/or the event or impact to the Project.
 - b. Reasonable order of magnitude estimate of the change to the Contract Price;
 - c. Reasonable order of magnitude estimate of the time impact to the Contract Time; and
 - d. Contractual provisions and substantive basis to support the Request.

B. Request for Change Order.

1. Within twenty-one (21) days after the Direction and/or the onset of the event or impact to the Project, the Contractor may request an extension of time for filing its Request for Change Order. The Contractor shall state the reasons for the request and identify a date certain when the Contractor shall provide all documentation required in its Request for Change Order.
2. Unless the Port's Project Representative issues written Notice authorizing the Contractor additional time to submit the Request for Change Order, the Contractor shall provide, in writing, a detailed Request for Change Order to the Port's Project Representative no later than thirty-five (35) days after the Direction and/or the onset of the event or impact to the Project.
3. The Request for a Change Order shall include:
 - a. Specific dollar amount covering all costs associated calculated in accordance with Article 6, Time and Price Adjustments;
 - b. Specific request for time extension (number of days) calculated in accordance with Article 6, Time and Price Adjustments;
 - c. A copy of the written Notice of intent, including all attachments; and
 - d. All documentation supporting the Request for a Change Order, including but not limited to a cost proposal, all cost records, schedule analysis, and the documents identified in paragraph 3.10, Maintenance and Inspection of Documents, that are in any way relevant to the Contractor's Request for Change Order.

C. Port's Response to Contractor's Request for Change Order.

1. Port will make a written determination with respect to the Contractor's Request For Change Order within thirty (30) days of receipt of said Request, unless one of the following activities occurs.
 - a. Port may request additional information and specify a time period for receipt of the information. The Contractor shall comply with Port's request for additional information.
 - b. Port may inform the Contractor that additional time is needed to review the Contractor's Request for Change Order and identify a date certain when a decision will be rendered.
2. If Port requests additional information, Port will make a written determination within thirty (30) days receipt of Contractor's additional information.
3. If Port does not make a determination within the applicable time period, the Request For Change Order is deemed denied.

D. Approval of Request for Change Order and Execution of Change Order. If Port determines that a Change Order is necessary, the Parties may negotiate acceptable terms and conditions and execute a Bilateral Change Order or Port may issue a Unilateral Change Order (*See* Section 5.6).

E. Contractor Procedure upon Denial or Deemed Denial of a Request for a Change Order. If the Contractor disagrees with the denial, the Contractor's sole remedy shall be to file a fully documented Claim within thirty (30) days of deemed denial or the Contractor's receipt of the denial in accordance with Article 9, Claims and Dispute Resolution.

F. Contractor's Obligation to Continue to Work. Pending resolution of the Contractor's Request for a Change Order, the Contractor shall continue to perform all Work including, at the written request of Port that work associated with the pending Request for Change Order. The Contractor shall maintain its progress with the Work.

G. Waiver. Failure to follow the provisions set forth herein shall constitute a waiver of the Contractor's right to receive any additional time or money as a result of any alleged direction, instruction, interpretation, determination by Port and/or the event or impact to the Project.

5.2. DIFFERING SITE CONDITIONS

A. Immediate Written Notice to Port. If the Contractor encounters a Differing Site Condition as defined in Article 1.0 the Contractor shall immediately, and before the conditions are disturbed, give written Notice to Port of Differing Site Conditions.

B. Request for Change Order based on Differing Site Condition. Unless otherwise agreed upon in writing by the Port's Project Representative, within forty-five (45) days of the Contractor's initial written notification of the Differing Site Condition to

Port, the Contractor shall provide a Request for Change Order that includes all elements required for such a request and:

1. A detailed description of the Differing Site Condition; and
2. Substantive, contractual, and technical basis supporting the existence of the Differing Site Condition and its impacts.

C. Waiver.

1. If the Contractor's actions disturb the Site such that Port or Port's designee cannot adequately and fully investigate the alleged differing site condition, the Contractor waives its right to receive any additional time or money as a result of the Differing Site Condition.
2. Failure by the Contractor to provide either (a) immediate Notice or (b) Request for Change Order shall constitute a waiver of the Contractor's right to receive any additional time or money as a result of the Differing Site Condition.
3. The Contractor shall be responsible for any and all costs or damages incurred by Port resulting from the Contractor's failure to provide appropriate notice and/or the Detailed Description and Request for Change Order.

D. Port's Response to the Differing Site Condition Request for Change Order. Port shall investigate the alleged Differing Site Conditions and respond to the Differing Site Condition in accordance with the Request for Change Order procedures set forth above.

E. Contractor's Obligation to Continue to Work. The Contractor shall not disturb the condition until receipt of written authorization from the Port's Project Representative that work can resume at the location of the alleged Differing Site Condition. The Contractor shall continue with performance of all other Work.

5.3. ACCELERATION

A. Acceleration Directive.

1. Port reserves the right to direct the Contractor to accelerate Contract Work. In the event that Port directs acceleration, such directive will be in writing and specifically designated as "Acceleration Directive."
2. The Contractor shall keep cost and other project records related to the Acceleration Directive separately from normal project costs and records and shall provide a written record of acceleration to Port on a daily basis.

B. Constructive Acceleration.

1. In the event that the Contractor believes that some action or inaction on the part of Port constitutes acceleration, the Contractor shall immediately notify Port in writing that the Contractor considers the actions an acceleration. This written notification shall detail the circumstances of the acceleration.

2. The Contractor shall not accelerate the Work until the Port's Project Representative responds in writing issuing an Acceleration Directive or denying the constructive acceleration.
 3. The Contractor shall keep cost and other project records related to the constructive acceleration separately from normal project costs and records and shall provide a written record of acceleration to Port on a daily basis.
- C. To the extent the Contractor believes an acceleration directive or constructive acceleration constitutes a change in the Work impacting Contract Price and/or Contract Time, the Contractor shall submit a Request for a Change Order to Port pursuant to Article 5, Changes to the Contract.
- D. Labor costs recoverable will be overtime or shift premium costs. Equipment costs recoverable will be only the rental cost of additional equipment or Contractor-owned additional equipment mobilized to the Site to accomplish the accelerated Work effort.

5.4. SUSPENSION OF WORK

A. Port Issues Directive Suspending Work

1. Port may order the Contractor, in writing, to suspend all or any part of the Work of this Contract for the period of time that Port determines appropriate for the convenience of Port. The Contractor shall not suspend the Work without written direction from Port specifically authorizing the Suspension of Work.
2. Upon receipt of a written Notice suspending the Work, the Contractor shall immediately comply with its terms and take all reasonable steps to minimize costs attributable to such suspension. Within a period up to 120 days after the suspension notice is received by the Contractor, or within any extension of that period which Port requires, Port shall either:
 - a. Cancel the written notice suspending the Work; or,
 - b. Terminate the Work for either default or convenience.
3. If a written notice suspending the Work is canceled or the period of the Suspension or any extension thereof expires, the Contractor shall resume Work as required by Port.

B. Constructive Suspension of Work

1. In the event that the Contractor believes that some action or omission on the part of Port constitutes constructive suspension of Work, the Contractor shall immediately notify Port in writing that the Contractor considers the actions or omission a constructive suspension of Work. This written notification shall detail the circumstances of the constructive suspension of Work.
2. The Contractor shall keep cost and other project records related to the constructive suspension separately from normal project costs.

- C. To the extent the Contractor believes it is entitled to any additional money or time as a result of the suspension of Work or constructive suspension, Contractor shall submit a Request For Change Order to Port as more fully described in Article 5, Changes to the Contract. The Contractor shall provide a Request for Change Order within thirty-five (35) days of (1) Port's Notice canceling the suspension or (2) termination of the Work.
 - 1. The Contractor's recovery is limited to actual unabsorbed home office overhead minus the Overhead and Profit markup calculated in accordance with paragraph 6.3, Allowable Costs.
- D. Failure to comply with these requirements shall constitute a waiver of Contractor rights to any adjustment in Contract Time and/or Contract Price.
- E. No adjustment shall be made under this provision for any suspension to the extent that Contractor's performance would have been suspended, delayed, or interrupted as a result of actions, omissions, fault or negligence caused, in whole or in part, by the Contractor or any of its Subcontractors.

5.5. FORCE MAJEURE

- A. To the extent the Contractor believes it is entitled to any additional time as a result of Force Majeure, Contractor shall submit a Request For Change Order to Port as more fully described in Article 5, Changes to the Contract.
- B. Contractor shall not be entitled to a change in Contract Price resulting from an act of Force Majeure.
- C. Contractor is not entitled to an adjustment in Contract Time if the act of Force Majeure did not impact progress of the Work on the Critical Path and delay the Contractor from completing Contract Work within Contract Time.
- D. When a Contractor experiences concurrent delay caused by either Port or Contractor and an act of Force Majeure, the Contractor shall only be entitled to a change in Contract Time. No change to the Contract Price shall be allowed as a result of such concurrent delay.

5.6. CHANGE ORDERS

A. Bilateral Change Orders

- 1. If Port and Contractor reach agreement on the terms and conditions of any change in the Work, including any adjustment in the Contract Price and Contract Time, such agreement shall be incorporated into a Change Order and signed by both Parties. Such Bilateral Change Orders shall represent full and complete payment and final settlement of all changes, Claims, damages or costs for all (a) time; (b) direct, indirect, and overhead costs; (c) profit; and (d) any and all costs or damages associated with delay, inconvenience, disruption of schedule, impact, ripple effect, loss of efficiency or productivity, acceleration of work, lost profits, stand-by, and any other costs or damages related to any work either covered or affected by the Change Order, or related to the events giving rise to the Bilateral Change Order.

B. Construction Change Directive

1. **Port's Right to Issue Construction Change Directive** A Construction Change Directive is a written order signed by the Owner, directing a change in the Work prior to agreement on adjustment, if any, in the Contract Price or Contract Time, or both. The Owner may by Construction Change Directive, without invalidating the Contract and without notice to the sureties, order changes in the Work within the general scope of the Contract consisting of additions, deletions, or other revisions, the Contract Sum and Contract Time being adjusted accordingly.
2. **Contractor Responsibility and Response to Construction Change Directive Order.** Upon receipt of a Construction Change Directive, the Contractor shall promptly proceed with the change in the Work involved and advise the Owner of the Contractor's agreement or disagreement with the method, if any, provided in the Construction Change Directive for determining the proposed adjustment, if any, in the Contract Sum or Contract Time.
3. **Contractor Disagreement with Unilateral Change Order.** If the Contractor disagrees with the adjustment to the Contract Price and/or Time as indicated in the Unilateral Change Order, the Contractor's remedy shall be to file a Claim in accordance with Article 9, Claims and Dispute Resolution.
4. A Construction Change Directive signed by the Contractor indicates the Contractor's agreement therewith, including adjustment in Contract Price and Contract Time or the method for determining them. Such agreement shall be effective immediately and shall be recorded as a Change Order.

5.7. PORT REQUEST FOR A CHANGE PROPOSAL

- A. **Request.** Port may request a written Change Proposal from the Contractor for a change in the Contract Work.
- B. **Contractor's Proposal.** Contractor shall submit its written Change Proposal within the time specified in Port's request. The Change Proposal shall represent the Contractor's offer to perform the requested work, and the pricing set forth within the proposal shall represent full, complete, and final compensation for the proposed change and any impacts to any other Contract Work, including any adjustments in the Contract Time.
- C. **Port's Acceptance of Contractor Proposal.**
 1. If Port accepts the Change Proposal as submitted by the Contractor or as negotiated by the parties, Port shall notify the Contractor in writing of its acceptance of the Proposal and direct that the change in the Work be performed.
 2. Contractor shall not perform the work identified in the Change Proposal until receipt of written authorization from the Port's Project Representative.
 3. Both Parties shall acknowledge acceptance of the terms of a negotiated Change Proposal in writing.

4. Once Port and Contractor have agreed on the terms of a negotiated Change Proposal, the negotiated Change Proposal shall represent full and complete compensation and final settlement of all Claims for all (1) time; (2) direct, indirect, and overhead costs; (3) profit; and (4) costs or damages associated with delay, inconvenience, disruption of schedule, impact, ripple effect, loss of efficiency or productivity, acceleration of work, lost profits, and/or any other costs or damages related to any work either covered or affected by the Change Proposal, or related to the events giving rise to the Change Proposal.
- D. **Execution of a Bilateral Change Order.** After acceptance of the Change Proposal or acceptance of the negotiated Change Proposal, Port shall direct the Contractor to perform the work in accordance with the agreed upon terms. Such agreement shall be effective immediately and shall be recorded as a Change Order.
 - E. **Execution of Construction Change Directive .** If Port does not accept the Contractor's Change Proposal or the Parties cannot agree upon the appropriate price or terms for the Change Proposal, Port may issue a Construction Change Directive pursuant to Section 5.6.B herein above.

ARTICLE 6: TIME AND PRICE ADJUSTMENTS

6.0. CHANGE IN THE CONTRACT TIME

- A. Unless otherwise provided, Contract Time is the period of time, including authorized adjustments, allotted in the Contract Documents for Substantial Completion of the Work.
- B. The Contract Time shall only be changed by a Change Order.
- C. Contractor shall include any request for a change in the Contract Time in its Notice of Intent to submit a Request for Change Order, Request for Change Order, Change Proposal and Claim.
- D. No change in the Contract Time shall be allowed to the extent the time of performance is changed due to the fault, act, or omission of Contractor, or anyone for whose acts or omissions the Contractor is responsible.
- E. If the Contractor is delayed at any time in the commencement or progress of the Work by (1) an act or neglect of the Owner, or of a Separate Contractor; (2) by changes ordered in the Work; (3) by labor disputes, fire, unusual delay in deliveries, unavoidable casualties, adverse weather conditions documented in accordance with Section 15.1.6.2, or other causes beyond the Contractor's control; (4) by delay authorized by the Owner pending mediation and binding dispute resolution; or (5) by other causes that the Contractor asserts, and the Owner determines, justify delay, then the Contract Time shall be extended for such reasonable time as the Owner may determine.
- F. A Request for Change Order that includes a request for an adjustment in the Contract Time shall:

1. Be in writing and delivered to Port within the appropriate time period specified in Article 5, Changes in the Contract.
 2. Include a clear explanation of how the event or conditions specifically impacted the Critical Path and overall Project Schedule and the amount of the adjustment in Contract Time requested.
 3. Be limited to the change in the Critical Path of a Contractor's Project Schedule, and any updates, attributable to the event or conditions, which caused the request for adjustment. Contractor shall be responsible for showing clearly on the Project Schedule, and any updates, that the event or conditions:
 - a. Had a specific impact on the Critical Path and was the sole cause of such impact;
 - b. Could not have been avoided by re-sequencing of the Work or other reasonable alternatives; and
 - c. Will prevent the Contractor from completing the Project within the current Contract completion date.
- G. Contractor shall make all reasonable efforts to prevent and mitigate the effects of any delay, whether occasioned by an act of Force Majeure or otherwise.
- H. The Contractor's sole remedy for delays shall be an extension of time. Except for unreasonable delays in performance caused by the acts or omissions of the Owner, the Contractor shall not be entitled to damages, extra compensation or equitable adjustment for direct, indirect or impact damages for delay, including but not limited to cost of acceleration, home office overhead or lost profits. All claims for damages or extensions of time are subject to the requirements of Section 9.0. In the event the Contractor is entitled to damages from the Owner for delay, it is agreed that the Contractor's sole damages for each day of delay shall be limited to the daily liquidated damage rate provided for the Owner in subparagraph 10.7 below. above.

6.1. CHANGE IN THE CONTRACT PRICE

- A. The Contract Price shall only be changed by a Change Order.
- B. Contractor shall include any request for a change in the Contract Price in its:
1. Change Proposal;
 2. Notice of intent to submit a Request for Change Order;
 3. Request For a Change Order; and
 4. Claim, provided the related Request for Change Order and/or Change Proposal included a request to adjust the Contract Price.
- C. No change in the Contract Price shall be allowed when:

1. Contractor's changed cost of performance is due to the fault, acts, or omissions of Contractor, or anyone for whose acts or omissions Contractor is responsible, including its subcontractors and suppliers.
 2. The change is concurrently caused by Contractor and Port; or
 3. The change is caused by an act of a third party or Force Majeure.
- D. Port shall not be responsible for, and the Contractor shall not be entitled to any compensation for unallowable costs. Unallowable costs include, but are not limited to:
1. Interest or attorney's fees of any type other than those mandated by Washington state statute;
 2. Claim preparation or filing costs;
 3. The cost of preparing or reviewing Change Proposals or Requests for Change Orders;
 4. Lost profits, lost income or earnings;
 5. Costs for idle equipment when such equipment is not at the Site, has not been employed in the Work, or is not scheduled to be used at the Site;
 6. Lost earnings or interest on unpaid retainage;
 7. Claims consulting costs;
 8. The costs of corporate officers or staff visiting the Site or participating in meetings with Port;
 9. Any compensation due to the fluctuation of foreign currency conversions or exchange rates;
 10. Loss of other business; and/or
 11. Any other special, consequential, or incidental damages incurred by the Contractor, Subcontractor, or Suppliers.
- E. A Request for Change Order that includes a request for an adjustment in Contract Price shall:
1. Be in writing and delivered to Port within the applicable time period specified in Article 5, Changes to the Contract.
 2. Identify the following information:
 - a. The event or condition which caused the Contractor to submit its request for an adjustment in the Contract Price;
 - b. The nature of the impacts to Contractor and its Subcontractors, if any; and,

- c. The amount of the adjustment in Contract Price requested calculated in accordance with Paragraph 6.3, Allowable Costs, and using forms provided by Port.
 3. Any requests by Contractor for an adjustment in the Contract Price and in the Contract Time that arise out of the same event or conditions shall be submitted together.
- F. The adjustments to the Contract Price provided for in this Article represent full, final, and complete compensation for all work done in connection with the request for an adjustment in Contract Price and all costs related to, resulting from, or affected by such change in Work including, but not limited to, all direct and indirect costs, overhead, profit, and all costs or damages associated with delay, inconvenience, disruption of schedule, impact, dilution of supervision, inefficiency, ripple effect, loss of efficiency or productivity, acceleration of work, lost profits, and any other costs or damages related to any work either covered or affected by the change in the Work, or related to the events giving rise to the change.

6.2. METHOD TO CALCULATE ADJUSTMENTS TO CONTRACT PRICE

- A. One of the following methods shall be used to calculate damages and/or adjustments to the Contract Price that result from or relate to Change Proposal, Request for Change Order, and/or Claim.
- B. Determination of the method to be used to calculate adjustments in the Contract Price shall be at the sole discretion of Port.
- C. One of the following methods shall be used:
 1. Unit Price Method;
 2. Firm Fixed Price Method (also known as Lump Sum); or,
 3. Time and Materials Method.
- D. **Unit Price Method**
 1. The Port may direct the Contractor to perform extra Work on a Unit Price basis. Such authorization shall clearly state the:
 - a. Scope of work to be performed;
 - b. Applicable Unit Price; and,
 - c. Not to exceed amount of reimbursement as established by Port.
 2. The applicable unit price shall include reimbursement for all direct and indirect costs of the Work, including Overhead and profit, as limited by paragraph 6.3, Allowable Costs.

3. Contractor shall only be paid under this method for the actual quantity of materials incorporated in or removed from the Work and such quantities must be supported by field measurement statements verified by Port.

E. Firm Fixed Price Method

1. The Contractor and Port may mutually agree on a fixed amount as the total compensation for the performance of changed work.
2. The Contractor shall provide a detailed cost breakdown supporting the Contractor's requested adjustment to Contract Price and any other financial documentation requested by the Port's Project Representative, as limited by paragraph 6.3, Allowable Costs.
3. Any adjustments to the Contract Price using the Firm Fixed Price Method shall include, when appropriate all reasonable costs for labor, equipment, material, Overhead and profit. Such labor, equipment, material, Overhead and profit shall be calculated in accordance with paragraph 6.3, Allowable Costs
4. Whenever Port authorizes Contractor to perform changed work on a Firm Fixed Price Method, Port's authorization shall clearly state:
 - a. Scope of Work to be performed; and,
 - b. Total Fixed Price payment for performing such work.

F. Time and Materials Method

1. Whenever Port authorizes the Contractor to perform Work on a Time and Material basis, Port's authorization shall clearly state:
 - a. Scope of Work to be performed; and,
 - b. A not to exceed amount of reimbursement as established by Port.
2. Contractor shall:
 - a. Cooperate with Port and assist in monitoring the Work being performed;
 - b. Substantiate the labor hours, materials and equipment charged to work under the Time and Materials Method by detailed time cards or logs completed on a daily basis before the close of business each working day;
 - c. Present the time card and/or log at the close of business each day to the Port's Project Representative so that Port may review and initial each time card/log;
 - d. Perform all Work in accordance with this provision as efficiently as possible;
 - e. Not exceed any cost limit(s) without Port's prior written approval; and
 - f. Maintain all records of the work, including all records of the Subcontractor, Supplier, and Materialmen, and make such records available for inspection as

required in paragraphs 3.8, Record Documents, 3.9, Cost Records, and 3.10, Maintenance and Inspection of Document.

3. Contractor shall submit costs and any additional information requested by Port to support Contractor's requested price adjustment.
4. The Contractor shall only be entitled to be paid for reasonable costs actually incurred by the Contractor. The Contractor has a duty to control costs. If Port determines that the Contractor's costs are excessive or unreasonable, Port, at its discretion, shall determine the reasonable amount for payment.

G. Deductive Changes to the Contract Price

1. A deductive change to the Contract Price may be determined by taking into account:
 - a. Costs incurred and saved by the Contractor as a result of the change, if any;
 - b. The costs of labor, material, equipment, and overhead saved and profit unearned by the deleted work. These costs shall be calculated following as closely as possible with the provisions identified in Article 6, Time and Price Adjustments; and/or,
 - c. At the discretion of Port, costs set forth in the documents used by the Contractor to develop its bid.
2. Where Port has elected not to correct incomplete or defective Work, the adjustment in the Contract Price shall take into account:
 - a. The costs the Port would have to expend to correct the Work;
 - b. The decreased value to Port resulting from the incomplete or defective Work; and,
 - c. The increased future costs which Port may incur by reason of the incomplete or defective Work.

H. Full Compensation

An adjustment calculated in accordance with the provisions of this Article shall be full and complete payment and final settlement of all changes, claims, damages and costs for all (a) time; (b) direct, indirect, and overhead costs; (c) profit; and (d) any and all costs or damages associated with delay, inconvenience, disruption of schedule, impact, ripple effect, loss of efficiency or productivity, acceleration of work, lost profits, standby, and/or any other costs or damages related to any Work either covered or affected by the changed work, or related to the events giving rise to the change.

6.3. ALLOWABLE COSTS

- A. Any adjustments to the Contract Price shall be based on the following categories and shall incorporate markups for Overhead and profit as provided herein.

1. **Labor.** For all labor, including foreman supervision but excluding superintendents, the Contractor shall be reimbursed for labor costs provided herein. The labor cost of an event or condition shall be calculated as the sum of the following:
 - a. **Labor Rate.** The Labor Rate is the actual reasonable wage paid to the individual plus the actual reasonable costs incurred by the Contractor to cover costs associated with Federal Insurance Compensation Act (FICA), Federal Unemployment Tax Act (FUTA), State Unemployment Tax Act (SUCA), industrial insurance, fringe benefits, and benefits paid on behalf of labor by the Contractor. The applicable Labor Rates shall be multiplied by the number of hours reasonably expended in each labor classification because of the event or condition to arrive at a total cost of labor.
 - b. **Travel Allowance and/or Subsistence.** The labor calculation shall include the actual costs of travel and/or subsistence paid to the Contractor's employees engaged upon the Work when said payments are required by a labor agreement.
2. **Materials.** The cost of materials resulting from an event or condition shall be calculated in one or more of the following methods, at Port's election:
 - a. **Invoice Cost.** The Contractor may be paid the actual invoice cost of materials including actual freight and express charges and applicable taxes less all available discounts, rebates, and back-charges. This method shall be considered only to the extent the Contractor's invoice costs are reasonable as determined by Owner and the Contractor provides copies of vendor invoices, freight and express bills, and other evidence of cost accounting and payment satisfactory to Owner. As to materials furnished from the Contractor's stocks for which an invoice is not available, the Contractor shall furnish an affidavit certifying its actual cost of such materials and such other information as Owner may reasonably require;
 - b. **Wholesale Price.** The Contractor may be paid the lowest current wholesale price for which the materials are available in the quantities required, including customary costs of delivery and all applicable taxes less all available discounts, rebates, and back-charges; or,
 - c. **Port Furnished Material.** Port reserves the right to furnish such materials as it deems advisable, and the Contractor shall have no Claim for any costs, Overhead or profit on such materials. However, should the Contractor be required to pick up, transport and/or unload such materials the Contractor will be reimbursed for reasonable costs thereof.
3. **Equipment.** The additional cost, if any, of machine-power tools and equipment usage shall be calculated in accordance with the following rules:
 - a. **Equipment Rates.** The Contractor's own charge rates may be used if verified and approved by Port and based on the Contractor's actual ownership and operating cost experience. Rental rates contained in published rate guides may be used if their cost formulas and rate factors are identifiable, reflect the

Contractor's historical acquisition costs, utilization, and useful life, and do not include replacement cost, escalation contingency reserves, general and administrative expense, or profit. Rates shall be based on the Contractor's actual allowable costs incurred or the rates established according to the Rental Rate Blue Book for Construction Equipment, published by Equipment Watch, PRIMEDIA, whichever is less. The Rental Rate Blue Book established hourly equipment rate shall be the monthly rental rate for the equipment plus the monthly rental rate for required attachments, divided by 176 work hours per month, multiplied by the appropriate regional adjustment factor, plus the hourly operating cost. The established equipment rate shall apply for actual equipment usage up to eight hours per day. For all hours in excess of eight hours per day or 176 hours per month, the established equipment rate shall be the monthly rental rate plus the monthly rental rate for required attachments, divided by 352, multiplied by the regional adjustment factor, plus the hourly operating cost.

- b. **Transportation.** If the necessary equipment is not already at the Site and it is not anticipated that it would be required for the performance of other Work under the terms of the Contract, the calculation shall include a reasonable amount for the costs of the necessary transportation of such equipment.
 - c. **Standby.** The Contractor shall only be entitled to standby equipment costs if (a) the equipment is ready, able, and available to do the Work at a moment's notice; (b) Contractor is required to have equipment standby because of an event or condition solely caused by Port and (c) the Contractor can demonstrate that it could have and intended to use the equipment on other projects/jobs. The Contractor shall be compensated at 50% of the monthly rental rate for the equipment, divided by 176, and multiplied by the appropriate regional adjustment factor, as identified in the Rental Rate Blue Book for Construction Equipment, published by Machinery Information Division of PRIMEDIA Information Inc. Standby shall not be paid during periods of Contractor-caused delay, concurrent delay, Force Majeure, during any seasonal shutdown, routine maintenance, down-time or broken equipment, late delivery of equipment or supplies, or other anticipated occurrence specified in the Contract Documents. No payment shall be made for standby on any piece of equipment, which has been used on the Project in any 24 hour period. Standby costs shall not be paid for weekends, holidays, and any time the equipment was not intended to be used on the Project as demonstrated by the Project Schedule.
4. **Subcontractor & Supplier.** Direct costs associated with Subcontractors and Suppliers shall exclude Overhead and Profit markups and shall be calculated and itemized in the same manner as prescribed herein for Contractor. Contractor shall provide detailed breakdown of Subcontractor and Supplier invoices.
 5. **Overhead and Profit Markup.**
 - a. On a change to the Contract Price or any other claim for money by the Contractor, Port will only pay Overhead, including Home Office Overhead, Site or Field Office Overhead, and unabsorbed home office overhead, and Profit pursuant to the Overhead and Profit Markups set forth herein. The

Overhead and Profit Markups cover all overhead regardless of how the Contractor chooses to account for various costs in its books of account.

- b. Overhead and Profit markups shall not be applied to freight, delivery charges, express charges, and sales tax.

- c. The allowed Overhead and Profit markup shall not exceed the following:

If the Contractor is self-performing work: 18% combined Overhead and Profit markup on the Contractor's Direct Costs; or

If a Subcontractor or Supplier is performing work: 18% for the Subcontractor's Direct Cost for performing the work and 7% on the Direct Costs of the Subcontractors' or Suppliers'; provided that the

7% is to be divided among upper tier Subcontractors and the Contractor when a Subcontractor or Supplier is performing the work.

If the value of material and equipment is greater than 50% of the total value of the change, the Overhead and Profit Markup shall only be 10% for material and equipment.

In no event shall the total combined Overhead and Profit markup for the Contractor and all Subcontractors and Suppliers of any tier exceed 25% of the Direct Cost to perform the Change Order work.

- d. Direct Costs shall include Labor (as defined in ¶ 6.3 A.1), Materials (as defined in ¶ 6.3 A.2), Equipment (as defined in ¶ 6.3 A.3), and Subcontractor and Supplier Costs (as defined in ¶ 6.3 A.4).

ARTICLE 7: PAYMENT AND COMPLETION

7.0. APPLICATIONS FOR PAYMENT

- A. On or about the first day of each month, the Contractor shall submit to Port an Application for Payment. Each application shall be on a form acceptable to Port and designated as an "Application for Payment." The Contractor shall include with each Application for Payment:

1. Current cost status of work completed per the Schedule of Values or cost loaded CPM schedule;
2. Project Schedule and the most current updates;
3. A signed statement that the Record Drawings are up to date;
4. Affidavits signed by all Subcontractors performing Work to date, stating that each of them has been paid, less earned retainage, as their interests appeared in the last preceding Application for Payment;
5. List of all subcontractors who performed work during the current billing period (Use Port approved form).

- B. Inclusion of the required documentation is a condition precedent to payment. The Contractor is not entitled to payment for any work unless the Application for Payment includes all required documentation. Port reserves the right to withhold payment pursuant to paragraph 7.2, Payments Withheld if it is subsequently determined that all required documentation was not provided by the Contractor or is in error.
- C. The application shall correlate the amount requested with the Schedule of Values or cost loaded schedule and with the state of completion of the Work, as measured by the current Project Schedule. In addition to Work performed by the Contractor, applications may include (1) the invoiced cost of major materials or equipment (major material or equipment to be identified on the Schedule of Values or cost loaded schedule) suitably stored on the Site, and (2) with Port's consent, up to 75% of the invoiced cost of major materials or equipment suitably stored off the Site if Port's interest in those major materials or equipment is protected through proper secure storage and insurance and the Contractor provides documentation of such insurance.
- D. Contractor shall be required to complete the Statement of Intent to Pay prevailing Wages and Affidavit of Wages Paid form and submit to Port before any payment will be processed.

7.1. PAYMENTS

- A. Port shall comply with RCW 39.76, as amended, and promptly review each Application for Payment and identify in writing any cause for disapproval within eight (8) working days. In addition to withholding payment for unsatisfactory performance or failure to comply with Contract requirements, if the Contractor's Application for Payment fails to recognize any back-charges, off-sets, credits, change orders, or deductions in payment made in accordance with paragraph 7.2, Payments Withheld, Port shall have the right to revise or disapprove Contractor's Application For Payment because the Application for Payment is not considered a properly completed invoice.
- B. If an Application for Payment is accepted by Port, it shall be paid within thirty (30) days of Port's receipt of the properly prepared invoice (Application for Payment).

7.2. PAYMENT WITHHELD

- A. In addition to moneys retained pursuant to RCW 60.28 and without waiver of any other available remedies, Port has the right to withhold, nullify, or back-charge, in whole or in part, any payment or payments due or that have been paid to the Contractor as may be necessary to cover Port's costs or to protect Port from loss or damage for reasons including but not limited to:
 - 1. Failure of the Contractor to submit or obtain acceptance of a Progress Schedule, Schedule of Values, and any updated Schedules;
 - 2. Defective or non-conforming Work;
 - 3. Costs incurred by Port to correct, repair or replace defective or non-conforming Work, or to complete the Work;

4. A reasonable doubt that the Contract can be completed for the balance then unpaid;
 5. A reasonable concern by Port that the materials, equipment or component parts are not in proper operating condition;
 6. Assessment of Liquidated Damages;
 7. Failure to perform in accordance with the Contract;
 8. Cost or liability that may occur to Port as the result of the Contractor's or Subcontractor's acts, omissions, fault, or negligence, including failure to pay prevailing wage;
 9. Deduction in Contract Work;
 10. Failure of Contractor to repair damaged materials, equipment, property, or Work;
 11. Failure of the Contractor to obtain approval of Submittals pertinent to the work accomplished;
 12. Failure to pay Subcontractors or Suppliers;
 13. Failure to keep Record Documents up to date;
 14. Failure to comply with all applicable federal, state, and local laws, statutes, regulations, codes, licenses, easements, and permits;
 15. Failure to obtain and maintain applicable permits, insurance, and bonds;
 16. Failure to provide Statement of intent to Pay Prevailing Wage and/or Affidavits of Wages Paid approved by L&I; and
 17. Failure to comply with the Contract safety requirements.
- B. The withholding, nullification, or back-charge of any payment(s) by Port shall in no way relieve the Contractor of any of its obligations under this Contract.

7.3. TITLE

Title to all Work and materials covered by an accepted and paid Application for Payment shall pass to Port at the time of such payment, free and clear of all liens, claims, security interest, and encumbrances. Passage of title shall not, however, (1) relieve Contractor from any of its duties and responsibilities for the Work or materials, including protection thereof, (2) waive any rights of Port to insist on full compliance by Contractor with the Contract requirements, or (3) constitute acceptance of the Work or materials.

7.4. SUBSTANTIAL COMPLETION PROCEDURE

- A. Substantial Completion is the stage in the progress of the Work when the Work or portion thereof designated and approved by the Owner when the construction is sufficiently complete, in accordance with the Contract Documents, so the Owner can fully occupy under necessary permits the Work or portion thereof designated by the

Owner for the use for which it is intended. All Work other than incidental corrective or punch list work and final cleaning shall have been completed.

- B. When the Contractor considers that all Work or Work associated with Contract milestones is substantially complete, the Contractor shall give written Notice to Port, along with any Punch List of items to be completed or corrected prior to payment.
1. Port shall promptly inspect the Work and, if Port does not agree that the Work is substantially complete or that additional items should be included on the Punch List, Port will supplement the Punch List (list of items to be completed or corrected).
 - a. Port reserves the right to add to, modify, or change the Substantial Completion Punch List as circumstances dictate.
 - b. Failure by Port to include any items on such list does not alter the responsibility of the Contractor to complete or correct the Work in accordance with the Contract.
 2. When Port determines that those Punch List items have been completed or corrected by the Contractor, Port shall make a determination that the Work is Substantially Complete.
 3. A Certificate of Substantial Completion will be issued by Port, which shall establish the date of Substantial Completion, and be signed by the Contractor.
 4. This Certificate of Substantial Completion shall state the responsibilities of Port and the Contractor for security, maintenance, heat, utilities, damage to the Work, insurance, and the time to complete remaining Punch List work before liquidated damages begin to accrue for the Contractor's failure to achieve Completion/Final Acceptance in a timely manner.
 5. Port shall assess liquidated damages for the Contractor's failure to complete or correct the required Punch List items necessary to achieve Substantial Completion within the Contract Time for Substantial Completion.
 6. Except for any Claims properly submitted in accordance with Article 9, Claims and Dispute Resolution, the acceptance of the Substantial Completion payment shall constitute a waiver of all claims by the Contractor except those previously made in writing and identified by the Contractor as unsettled at the time of the application for the Substantial Completion payment, and except for the Contract Sums due at Final Acceptance and the Contractor shall, on behalf of itself and its Subcontractors or Sureties, forever and unconditionally release and discharge Port, its officers, agents, employees, from:
 - a. Any and all disputes or claims, including but not limited to claims for damages, fines, interest, taxes, attorney fees, or costs, demands, rights, actions or causes of actions, known or unknown, arising out of or in any way related to the parties' performance under the Contract and/or Project; and
 - b. Any and all known and/or unknown liabilities, obligations, demands, actions, suits, debts, charges, causes of action, requests for money and/or payment

under the Contract, outstanding invoices, or claims directly or indirectly arising out of or related to the Contract and/or Project.

- C. As provided in the Contract, Port may grant Substantial Completion to specific subsystems or portions of the Work. The dates of Substantial Completion shall be determined, in writing, by Port.

7.5. FINAL INSPECTION AND FINAL PUNCH LIST

- A. All remaining Punch List items that were not corrected prior to Substantial Completion shall be successfully completed by the Contractor prior to the Contractor's request for Final Acceptance. When the Contractor considers that all Contract Work is ready for final inspection and Final Acceptance, the Contractor shall give written Notice to Port.
- B. Port shall promptly perform a final inspection of the Work and, if necessary, prepare a Final Punch List (a list of items to be completed or corrected by the Contractor prior to Port granting Final Acceptance).
- C. Punchlist items may include but are not limited to: Copies of the warranties and guarantees required by the Contract; Permit approvals and Certificates of Occupancy; Operation and Maintenance Manuals; Record Set of Drawings and Specifications; and Stamped permit set of documents; Right of Way, Easements and Property Releases, and any other documents called for elsewhere in the Contract.
- D. The Contractor shall complete or correct the items identified in the Final Punch List within the time period as required in the Certificate of Substantial Completion or within 30 days, whichever is less. Should the Contractor fail to complete or correct all remaining Final Punch List items within the required time, Port may assess Liquidated Damages against the Contractor for failure to achieve Final Acceptance within the Contract Time.
- E. After the Contractor completes all items identified in the Final Punch List(s), the Contractor shall notify Port in writing that the Final Punch List items have been successfully completed. After verification by Port that such completion was satisfactory, the Contractor shall submit a Final Application for Payment.

7.6. REQUIREMENTS FOR FINAL APPLICATION FOR PAYMENT

- A. Neither Final Payment nor any retainage percentage shall become due until the Contractors submits to the Owner the following:
 - 1. Affidavit of Wages Paid for Contractor and all Subcontractors in accordance with state law;
 - 2. Contractor's release of claims against Port, except for Claims specifically described in the release document and submitted in accordance with Article 9, Claims and Dispute Resolution;
 - 3. Contractor certification that all Subcontractors and Suppliers have been paid and there are no outstanding liens;

4. Right of Way, Easements and Property Releases,
5. an affidavit that payrolls, bills for materials and equipment, and other indebtedness connected with the Work for which the Owner or the Owner's property might be responsible or encumbered (less amounts withheld by Owner) have been paid or otherwise satisfied,
6. a certificate evidencing that insurance required by the Contract to remain in force after final payment is currently in effect,
7. a written statement that the Contractor no reason that the insurance will not be renewable to cover the period required by the Contract Documents, of surety, if any, to final payment,
8. documentation of any special warranties, such as manufacturers' warranties or specific Subcontractor warranties, and
9. if required by the Owner, other data establishing payment or satisfaction of obligations, such as receipts and releases and waivers of liens, claims, security interests, or encumbrances arising out of the Contract, to the extent and in such form as may be designated by the Owner.

7.7. COMPLETION/FINAL ACCEPTANCE

- A. Completion/Final Acceptance shall be achieved when all the obligations of the Contract have been successfully performed by the Contractor in accordance with the Contract and accepted by Port. Should Contractor fail to achieve Final Acceptance within the required time the Port may assess liquidated damages for its failure to do so.
- B. Neither Final Acceptance, nor Final Payment, shall release Contractor or its sureties from any obligations under this Contract or the Performance and Payment Bonds, or constitute a waiver of any claims by Port arising from or related to Contractor's performance or failure to perform the Work and to meet all Contractual obligations in accordance with the Contract, including but not limited to:
 1. Unsettled liens, security interests or encumbrances;
 2. Damaged, non-conforming, or defective Work discovered by Port;
 3. Terms of any warranties or guarantees required by the Contract; and,
 4. Payments made in error.

7.8. RETAINAGE.

RCW Titles 39 and 60, concerning the rights and responsibilities of Contractor and Port with regard to retainage are made a part of the Contract by reference as though fully set forth herein. No retainage shall be processed until Contractor executes the Department of Revenue Release.

7.9. WARRANTY AND GUARANTY

- A. In addition to any special warranties provided elsewhere in the Contract, Contractor warrants that all Work conforms to the requirements of the Contract and is free from any defect in equipment, material, design, or workmanship performed by Contractor or its Subcontractors and Suppliers.
- B. The warranty period shall be for the longer period of: two years from the date of Final Acceptance of the entire Project or the duration of any special extended warranty offered by a supplier or common to the trade.
- C. With respect to all warranties, express or implied, for Work performed or materials furnished according to the Contract, Contractor shall:
 - 1. Obtain all warranties that would be given in normal commercial practice from the supplier and/or manufacturer;
 - 2. Prior to Final Acceptance require all warranties be executed, in writing, for the benefit of Port;
 - 3. Enforce all warranties for the benefit of Port; and,
 - 4. Be responsible to enforce any warranty of a Subcontractor, manufacturer, or Supplier, should they extend beyond the period specified in the Contract.
- D. If, within an applicable warranty period, any part of the Work is found not to conform to the Contract, the Contractor shall correct it promptly after receipt of written Notice from Port to do so. In the event Port determines that Contractor corrective action is not satisfactory and/or timely performed, then Port has the right to either correct the problem itself or procure the necessary services, recommendations, or guidance from third parties. All damages incurred by Port and all costs for Port's remedy shall be reimbursed by the Contractor.
- E. The warranty provided in this provision shall be in addition to any other rights or remedies provided elsewhere in the Contract or by applicable law.

7.10. PRIOR OCCUPATION

Port shall have the right to occupy such part or parts of the Project in or upon which the Work is being done, as it may see fit, before the Final Acceptance, and such occupation shall not be construed as acceptance by Port of the Work or constitute Substantial Completion of the Work.

ARTICLE 8: TERMINATION**8.0. PORT'S RIGHT TO TERMINATE CONTRACT****A. Termination for Default**

- 1. Port may terminate, without prejudice to any right or remedy of Port the Work, or any part of it, for cause upon the occurrence of any one or more of the following events:

- a. Contractor fails to prosecute the Work or any portion thereof with sufficient diligence to ensure Substantial Completion of the Work within the Contract Time;
 - b. Contractor fails to prosecute the Work or any portion thereof with sufficient diligence to ensure Final Acceptance of the Work in a timely manner;
 - c. Contractor is adjudged bankrupt, makes a general assignment for the benefit of its creditors, or a receiver is appointed on account of its insolvency;
 - d. Contractor fails in a material way to repair, replace or correct Work not in conformance with the Contract;
 - e. Contractor fails to supply skilled workers or proper materials or equipment;
 - f. Contractor fails to make prompt payment to its employees or Subcontractors, including payment of prevailing wage;
 - g. Contractor materially disregards or fails to comply with laws, ordinances, rules, regulations, permits, easements or orders of any public authority having jurisdiction;
 - h. Contractor fails to comply with all Contract safety requirements; or,
 - i. Contractor is otherwise in material breach of any provision of the Contract, including but not limited to quality control, environmental requirements, administrative requirements, coordination and supervision.
2. If Port reasonably believes that one of the aforementioned events has occurred, Port will provide the Contractor with not less than seven (7) days advance written Notice of its intent to terminate the Contractor for default, specifying within such notice the ground(s) for such termination. Port, at its option, shall require the Contractor to either promptly correct the deficiencies noted in Port's intent to terminate or provide Port with a corrective action plan as to how such deficiencies will be remedied or cured in a timely fashion. However, if after receipt of the proposed remedy, Port has a reasonable basis for concluding that the Contractor has (a) failed or is unwilling to repair, replace or correct the deficiencies, or (b) failed or is unwilling to provide a reasonable and satisfactory corrective action plan, Port shall thereafter have the right to terminate this Contract for default, subject to any prior rights of surety.
3. Upon termination, Port may at its option:
- a. Exclude Contractor from Site;
 - b. Take possession of the Site and possession of or use of all materials, equipment, tools, and construction equipment and machinery thereon owned by Contractor; and/or,
 - c. Finish the Work by whatever other reasonable method it deems expedient; or,

- d. Call upon the surety to perform its obligations under the performance and payment bonds, if applicable.
4. The Contractor and its sureties shall be liable for all damages and costs, including but not limited to: (1) compensation for architect and engineering services and expenses made necessary thereby; (2) any other costs or damages incurred by Port in completing and/or correcting the Work; and (3) any other special, incidental or consequential damages incurred by Port which results or arises from the breach or termination for default.
5. In the event of termination for default Port shall only pay the Contractor for Work successfully completed and accepted by Port prior to the date of termination. Port shall not be responsible for any other Contractor costs, expenses, or damages including any consequential, special, or incidental damages or lost profits associated with this Contract. In no event shall Port reimburse the Contractor for any costs directly or indirectly related to the cause of this termination for default.
6. If, after termination for default, it is determined that the Contractor was not in default, the rights and obligations of the parties will be the same as if the termination had been issued for the convenience of Port.
7. The rights and remedies of Port in this provision are in addition to any other rights and remedies provided by law or under this contract.

B. Termination for Convenience

1. Upon written Notice Port may terminate the Work, or any part of it, without prejudice to any right or remedy of Port, for the convenience of Port.
2. If Port terminates the Work or any portion thereof for convenience, Contractor shall recover as its sole remedy:
 - a. Reasonable costs for all Work completed prior to the effective date of the termination and not previously paid for by Port;
 - b. A reasonable allowance for Overhead and profit for Work actually performed and accepted by Port prior to the date of termination, at a rate not to exceed the percentage amount set forth in the Contract and in paragraph 6.3, Allowable Costs, subparagraph A.5, Overhead and Profit. The Contractor waives all other claims for payment and damages including without limitation, anticipated profit.
3. The Contractor shall not be entitled to any other costs or damages, whatsoever. The total sum payable upon termination shall not exceed the Contract Price reduced by prior payments. Contractor shall be required to make its request for adjustment in accordance with Article 5, Changes to the Contract, and Article 6, Time and Price Adjustments.
4. If it appears that the Contractor would have sustained a loss on the entire Contract had it been completed, Port shall not reimburse Contractor any profit for

the Work completed and shall reduce the settlement to reflect the indicated rate of loss.

C. Contractor's Obligations During Termination

Unless Port directs otherwise, after receipt of a written Notice of termination for default or termination for convenience, Contractor shall promptly:

1. Stop performing Work on the date and as specified in the Notice of termination;
2. Place no further orders or subcontracts for materials, equipment, services or facilities, except as may be necessary for completion of such portion of the Work not terminated;
3. Cancel all orders and subcontracts, upon terms acceptable to Port, to the extent that they relate to the performance of Work terminated;
4. Assign as specifically requested by Port all of the rights, title, and interest of Contractor in all orders and subcontracts;
5. Take such action as may be necessary or as directed by Port to preserve and protect the Work, Site, and any other property related to this Project in the possession of Contractor in which Port has an interest;
6. Continue performance of Work only to the extent not terminated; and,
7. Take any other steps required by Port with respect to this Project.

8.1. PORT'S RIGHT TO STOP THE WORK FOR CAUSE

- A. If Contractor fails or refuses to perform its obligations in accordance with the Contract, Port may order Contractor, in writing, to stop the Work, or any portion thereof, until satisfactory corrective action has been taken.
- B. Contractor shall not be entitled to any adjustment in the Contract Time and/or Contract Price for any increased cost or time of performance attributable to Contractor's failure or refusal to perform its obligations under the Contract.

ARTICLE 9: CLAIMS AND DISPUTE RESOLUTION

9.0. CONTRACTOR CLAIMS

- A. A Claim is a demand or assertion by one of the parties seeking, as a matter of right, payment of money, a change in the Contract Time, or other relief with respect to the terms of the Contract. The term "Claim" also includes other disputes and matters in question between the Port and Contractor arising out of or relating to the Contract. The responsibility to substantiate Claims shall rest with the party making the Claim. This Section 9.0 does not require the Port to file a Claim in order to impose liquidated damages in accordance with the Contract Documents
- B. Condition Precedent to Filing a Claim.

1. The following actions are a condition precedent to filing a Claim:
 - a. A Request for Change Order is denied or deemed denied by Port; or
 - b. A Unilateral Change Order is issued by Port.
- C. Failure to file a Timely Claim.
 1. At least seven (7) days prior to appropriate time to file a Claim, the Contractor may request an extension of time for filing its Claim. The Contractor shall state the reasons for the request and identify a date certain when the Contractor shall provide a fully documented Claim. Unless otherwise agreed to in writing by the Port's Project Representative, a fully documented Claim shall be received by the Port's Project Representative within thirty (30) days after:
 - a. Denial or deemed denial of a Request for Change Order; or
 - b. Contractor's receipt of an Executed Unilateral Change Order.
 2. Failure to comply with the time requirements set for filing a Claim shall constitute acceptance by the Contractor, on behalf of itself and its Subcontractors and Suppliers, of the Unilateral Change Order and/or Port's denial or deemed denial of a Request for Change Order. Such acceptance shall be considered complete, full, and final settlement of all costs, damages, and Claims related to or arising from the Request for Change Order and/or Unilateral Change Order.
- D. **Contractor's Obligation to Continue to Work.** Pending final decision of a Claim hereunder, the Contractor shall proceed diligently with the performance of the Contract Work, including that work associated with the Claim, and maintain its progress with the Work.
- E. **Information Required in a Fully Documented Claim.** Every Claim must be submitted by the Contractor, in writing and clearly designated by the Contractor as a fully documented Claim. At a minimum, a fully documented Claim must contain the following information:
 1. A detailed factual statement of the Claim providing all necessary details, locations, and items of Contract Work affected;
 2. The date on which facts arose that gave rise to the Claim;
 3. The name of each person employed or associated with the Contractor, Subcontractor, Supplier, and/or Port with knowledge about the event or condition which gave rise to the Claim;
 4. Copies of documents and a written description of the substance of any oral communications that concern or relate to the Claim;
 5. The specific provisions of the Contract Documents on which the Claim is based;
 6. If an adjustment in the Contract Price is sought, the exact amount sought, calculated in accordance with the Contract including paragraph 6.3, Allowable

Cost and accompanied by (a) all records supporting the Claim and (b) all records meeting the requirements of paragraph 3.10, Cost Records;

7. If an adjustment in the Contract Time is sought, the specific days and dates for which it is sought; the specific reason the Contractor believes an adjustment in the Contract Time should be granted; and the Contractor's analyses of its Progress Schedule, any specific Schedule analysis as required by the Contract Documents, and all updates to demonstrate the reason for the adjustment in Contract Time; and,
8. A statement certifying, under penalty of perjury, that after the exercise or reasonable diligence and investigation the Claim is made in good faith, that the supporting cost and pricing data are true and accurate to the best of the Contractor's knowledge and belief, that the Claim is fully supported by the accompanying data, and that the amount requested accurately reflects the adjustment in the Contract Price or Contract Time for which the Contractor believes Port is liable.

F. Contractor's Duty to Cooperate. The Contractor shall cooperate with Port or its designee in the evaluation of its Claim and provide all information and documentation requested by Port, its auditors or its designee.

G. Port's Evaluation of the Claim.

1. To assist Port in the review of the Contractor's Claim, Port or its designee may visit the Site, request additional information and/or documentation in order to fully evaluate the issues raised in the Claim and/or audit the Claim.
2. After the Contractor has submitted a fully documented Claim that complies with this provision, Port shall respond, in writing, to the Contractor within sixty (60) days from the date the fully documented Claim is received with either:
 - a. A decision regarding the Claim;
 - b. Written Notice extending for another thirty (30) days Port's time to respond to the Claim.
3. Absent a thirty (30) day extension, the Claim shall be deemed denied upon the sixty-first (61st) day following receipt of the Claim by Port. If Port had a thirty (30) day extension, the Claim shall be deemed denied upon the ninety-first (91st) day following receipt of the Claim by Port.
4. Port will identify the Appeal Officer for each Claim within fifteen (15) days of Port's receipt of a Claim.

H. Appeal Process of a Denial or Deemed Denial of the Claim.

1. Contractor shall notify Port of its disagreement with the denial or deemed denial of the Contractor's Claim and file a fully documented Appeal to the Appeal Officer within twenty-one (21) days after the deemed denial or receipt of the denial.

2. Failure to notify Port and file a fully documented Appeal constitutes acceptance of the denial or deemed denial and the Contractor waives any right to any adjustment in Contract Price and/or Contract Time with respect to the Claim.
3. A fully documented Appeal shall contain the following information:
 - a. All documentation and information previously provided to Port in support of the Contractor's Claim including but not limited to the documentation identified in paragraph 9.0, Contractor Claims, paragraph E;
 - b. A copy of Port's denial of the Claim;
 - c. A detailed explanation why the Contractor believes Port's decision is incorrect and why the Claim should be granted; and
 - d. Any technical data or additional documentation supporting the Contractor's position.
4. At the discretion of the Appeal Officer, the Appeal Officer may request additional information or a meeting with the Contractor.
5. After the Contractor has submitted a fully documented Appeal that complies with this provision, the Appeal Officer shall respond, in writing, to the Contractor within sixty (60) days from the date the Appeal is received. Absent a written response by the Appeal Officer, the Appeal shall be deemed denied upon the sixty-first (61st) day following receipt of the Appeal by the Appeal Officer.
6. Contractor shall notify Port of its disagreement with the denial or deemed denial of the Contractor's Appeal within twenty-one (21) days after the deemed denial or receipt of the denial. Failure to notify Port constitutes acceptance of the denial or deemed denial and the Contractor waives any right to any adjustment in Contract Price and/or Contract Time with respect to the Appeal.

9.1. CONTRACTOR'S BURDEN OF PROOF ON CLAIM

- A. The Contractor shall have the burden of proof to demonstrate entitlement and damages.
- B. If the Contractor, on behalf of itself or its Subcontractors and Suppliers seeks an adjustment in the Contract Price or Contract Time not supported by Project cost records meeting the requirements of ¶ 3.10, Cost Records, the Claim is waived.
- C. Compliance with the record keeping requirements set forth in this Contract is a condition precedent to recovery of any costs or damages related to or arising from performance of the Contract Work. If Port establishes non-compliance of the record-keeping requirement set forth in 3.10, Cost Records, no adjustment shall be made to the Contract Price and/or Contract Time with respect to that Claim.
- D. No Claim submitted to Alternative Dispute Resolution (ADR) shall seek damages greater than those set forth in the Contractor's Claim, except for accrual of any interest owing under applicable law.

9.2. DISPUTE RESOLUTION

- A. This Contract has been and shall be construed as having been made and entered into and delivered within the State of Washington and it is agreed by each party hereto that this Contract shall be governed by the laws of the State of Washington.
- B. In the event of a dispute regarding the enforcement, breach, default, or interpretation of this Contract, the Port and Contractor, or their designees, shall first meet in a good faith effort to resolve such dispute. In the event the dispute cannot be resolved by agreement of the parties, said dispute shall be first submitted to formal mediation through the American Arbitration Association mediation services, unless the parties agree to utilize another mediation service. If the dispute is not resolved through the formal mediation process, the parties agree to submit the dispute to binding arbitration utilizing the American Arbitration Association's arbitration rules for Construction, Real Estate & Environmental. Venue for such mediation and arbitration shall be Kennewick, Benton County, Washington, unless otherwise agreed between the parties. The prevailing party shall be entitled to its reasonable attorney fees and costs as additional award and judgment against the other.
- C. As provided in RCW 39.12.060, in the event a dispute regarding the applicable prevailing wage rate cannot be resolved by the Port and Contractor, said dispute regarding the prevailing wage rate shall be referred for arbitration to the director of the department of labor and industries of the state and his or her decision therein shall be final and conclusive and binding on all parties involved in the dispute.

ARTICLE 10: MISCELLANEOUS**10.0. CONTRACTOR'S PERFORMANCE AND PAYMENT BOND**

- A. The Contractor shall execute and deliver to Port a performance and payment bond for 100% of the Contract Price, on a form acceptable to Port with an approved surety company and in compliance with Chapter 39.08 RCW. Contractor shall notify surety of any changes in the work. The Contractor shall promptly furnish additional bond security to protect Port and persons supplying labor or materials required by the Contract if:
 - 1. Port has a reasonable objection to any surety;
 - 2. Any surety fails to furnish reports on its financial condition pursuant to Port's request; or,
 - 3. The Contract Price increases beyond the bond amount.

10.1. INDEMNIFICATION/HOLD HARMLESS

- A. The Contractor shall defend (in a manner reasonably acceptable to the Port and through legal counsel reasonably satisfactory to the Port), indemnify, and hold harmless the Port, its officers, officials, agents, employees, and volunteers ("Indemnitees") from and against any and all losses, demands, claims, damages, expenses, judgments or liabilities, including costs, attorneys' fees, taxes, fines, penalties, interest or other awards, that may be imposed on, incurred by or asserted

against Indemnitees, arising out of or in any manner connected with errors, negligent acts or omissions by Contractor, its servants, agents or employees, except for injuries and damages caused by the sole negligence of the Port, its officers, employees, agents, and volunteers.

- B. In the event of liability for damages arising out of bodily injuries or damages to property caused by or resulting from the concurrent negligence of the Contractor, and the Port, its officers, employees, agents and volunteers, the Contractor's liability and obligation to defend hereunder shall only be the proportionate extent of the Contractor's negligence.
- C. It is further agreed that the indemnification provided herein constitutes the Contractor's waiver of immunity under Industrial Insurance, Title 51 RCW, solely for the purposes of this indemnification.
- D. No liability shall attach to the Port by reason of entering into this Agreement except as expressly provided herein.
- E. This waiver has been mutually negotiated by the parties, and the provisions of this section shall survive the expiration or termination of this Agreement.
- F. Port may, in its sole discretion, (1) withhold amounts sufficient to pay the amount of any claim for injury, and/or (2) pay any claim for injury of which Port may have knowledge, regardless of the formalities of notice of such claim, arising out of the performance of this Contract.
- G. Any amount withheld will be held until the Contractor secures a written release from the claimant, obtains an arbitration decision that such claim is without merit, or satisfies any judgment on such claim. In addition, the Contractor shall reimburse and otherwise be liable for claims costs incurred by Port, including, without limitation, costs for claims adjusting services, attorneys, engineering, and administration.
- H. In the event Port incurs any judgment, award, and/or costs arising therefrom, including attorneys' fees, to enforce the provisions of this article, all such fees, expenses, and costs shall be recoverable from the Contractor.

10.2. COMPENSATION, WAGES, BENEFITS AND TAXES

Port assumes no responsibility for the payment of any compensation, wages, benefits, or taxes owed by the Contractor by reason of this Contract. The Contractor shall indemnify and hold Port, its elected officials, officers, agents and employees, harmless against all liability and costs resulting from the Contractor's failure to pay any compensation, wages, benefits or taxes.

10.3. SUCCESSORS AND ASSIGNS

Port and the Contractor each binds itself, its partners, successors, assigns and legal representatives to the other with respect to all covenants, agreements and obligations contained in the Contract. Neither party to the Contract shall assign the Contract or sublet it as a whole without the written consent of the other, nor shall the Contractor assign any moneys due or to become due to it hereunder, without the previous written consent of Port.

10.4. THIRD PARTY AGREEMENTS

Except as otherwise may be provided, the Contract shall not be construed to create a contractual relationship of any kind between: any architect, engineer, construction manager, Subcontractor, Supplier, or any persons other than Port and Contractor.

10.5. NONWAIVER OF BREACH

No action or failure to act by Port shall constitute a waiver of any right or duty afforded to Port under the Contract; nor shall any such action or failure to act by Port constitute an approval of or acquiescence in any breach hereunder, except as may be specifically stated by Port in writing.

10.6. NOTICE TO PORT OF LABOR DISPUTES

- A. If Contractor has knowledge that any actual or potential labor dispute is delaying or threatens to delay timely performance in accordance with the Contract, Contractor shall immediately give Notice, including all relevant information, to Port.
- B. Contractor agrees to insert a provision in its Subcontracts and to require insertion in all sub-subcontracts, that in the event timely performance of any such contract is delayed or threatened by any actual or potential labor dispute, all Subcontractor or lower-tiered Subcontractor shall immediately notify the next higher tier Subcontractor. Subcontractor or Contractor, as the case may be, of all relevant information concerning the dispute.

10.7. LIQUIDATED DAMAGES AGAINST CONTRACTOR

- A. Timely performance and completion of the Work is essential to Port and the time limits stated in the Contract are of the essence. Port will incur serious and substantial damages if Substantial Completion of the Work does not occur within the Contract Time.
- B. Final Acceptance of the Work is essential to Port and the time limits as identified by Port are of the essence. Port will incur serious and substantial damages if Final Acceptance of the Work does not occur as Port requires.
- C. The Parties acknowledge that the Contractor's failure to achieve Substantial Completion or Final Acceptance within the timeframe provided by this Contract will cause the Port to incur substantial economic damages and losses of types and in amounts which are impossible to compute and ascertain with certainty, and that liquidated damages represent a fair, reasonable and appropriate estimate thereof. Accordingly, in lieu of actual damages for such delay, the Contractor agrees that liquidated damages may be assessed and recovered by the Port as against the Contractor and its surety, in the event of delayed completion. Contractor shall be liable to the Port for payment of liquidated damages in the amount of One Thousand Dollars (\$1,000) for each day that completion of the Scope of Services is delayed beyond the time specified in this Contract as adjusted for time extensions approved in writing by the Port. Such liquidated damages are intended to represent estimated actual damages and are not intended as a penalty. Contractor shall pay them to the Port without limiting the Port's right to terminate this agreement for default as

provided elsewhere herein. Assessment of Liquidated Damages shall not release the Contractor from any further obligations or duties pursuant to the Contract Work.

10.8. HEADINGS

The headings used in the Contract are for convenience only and shall not be considered a part of or affect the construction or interpretation of any contractual provision therein.

10.9. CHOICE OF LAW

This Contract has been and shall be construed as having been made and entered into and delivered within the State of Washington and it is agreed by each party hereto that this Contract shall be governed by the laws of the State of Washington.

10.10. SEVERABILITY

The provisions of this Contract shall be effective in all cases unless otherwise prohibited by Washington State Law or applicable Federal Law. The provisions of this Contract are separate and severable. The invalidity of any sentence, paragraph, provision, section, Article, or portion of this Contract shall not affect the validity of the remainder of this Contract.

10.11. NONDISCRIMINATION

Contractor will not discriminate against any employee or applicant for employment on the grounds of race, creed, color, national origin, sex, marital status, age, sexual orientation, honorably discharged veteran or military status, or the presence of any sensory, mental or physical disability or the use of a trained dog guide or service animal by a person with a disability; provided that the prohibition against discrimination in employment because of handicap shall not apply if the particular disability prevents the proper performance of the particular worker involved. The Contractor shall ensure that applicants are employed, and that employees are treated during employment in the performance of this Contract without discrimination because of their race, creed, color, national origin, sex, marital status, age, sexual orientation, honorably discharged veteran or military status, or the presence of any sensory, mental or physical disability or the use of a trained dog guide or service animal by a person with a disability. Contractor shall take such action with respect to this Contract as may be required to ensure full compliance with local, State and Federal laws prohibiting discrimination in employment.

10.12. PUBLIC RECORDS

Contractor acknowledges that the Port is an agency subject to Chapter 42.56 RCW "Public Records Act." All preliminary drafts or notes prepared or gathered by the Contractor, and recommendations of the Contractor are exempt prior to the acceptance by the Port.

If the Contractor becomes a custodian of nonexempt public records of the Port and request for such records is received by the Port, the Contractor shall respond to the request by the Port for such records within five (5) business days by either providing the records, or by identifying in writing the additional time necessary to provide the records with a description of the reasons why additional time is needed. Such additional time shall not exceed twenty (20) working days unless extraordinary good cause is shown.

10.13. CONFIDENTIALITY; PUBLICITY; SECURITY

Contractor will not use or refer to Port, the Contract, any project worked on for the Port or any element thereof in any promotional or Contractor materials without the express prior written consent of the Port. If access to internal Port spaces/properties is necessary for the performance of the Services, Contractor agrees to provide the Port with personal information of Contractor personnel requiring such access and to comply with all security requirements of the Port. Contractor will not use, seek or obtain any unauthorized access to the Port network.

END OF SECTION 007000

CODE INFORMATION

GENERAL INFORMATION

WORK TO BE PERFORMED PER 2021 EBC IS "REPAIRS". THIS PROJECT WILL REPAIR A FIRE DAMAGED BUILDING BY REMOVING THE DAMAGED AREAS AND LEAVING AREAS TO REMAIN FOR STORAGE USE. OF THE EXISTING 12,000sqft WAREHOUSE BUILDING AND 1233sqft OFFICE AREA, 7,200sqft OF THE WAREHOUSE AND ALL OF THE OFFICE AREA ARE TO BE REMOVED DURING DEMOLITION. THE SOUTH WALL OF THE 4,800sqft WAREHOUSE BUILDING TO REMAIN WAS BUILT AS AN EXTERIOR NORTH WALL OF THE ORIGINAL 5,400sqft WAREHOUSE. SINCE THE WALL WAS ORIGINALLY DESIGNED AND CONSTRUCTED AS AN EXTERIOR WALL WHEN SUITE 6 WAS BUILT, THE STRENGTH OF THE WALL WILL NOT BE REDUCED OR ADVERSELY AFFECTED BY REMOVAL OF THE ROOF STRUCTURE ON THE SOUTH SIDE. LOAD DEMANDS ON THE WALL WILL NOT BE ANY MORE THAN WHEN IT WAS CONSTRUCTED AND ORIGINALLY PERFORMED AS AN EXTERIOR WALL. IN SOME RESPECTS, LOAD DEMAND ON THE WALL WILL ACTUALLY BE LESS AFTER SUITE 6 IS REMOVED.

OCCUPANCY CLASSIFICATION S-2

CONSTRUCTION TYPE V-B

BUILDING AREA

13,233 GSF - TOTAL EXISTING BUILDING AREA
 8,433 GSF - BUILDING AREA TO BE REMOVED (DEMOLISHED)
 4,800 GSF - BUILDING AREA TO REMAIN

ZONING CLASSIFICATION IH.

INSPECTION AUTHORITY

CITY OF KENNEWICK PHONE: (509) 585-4561

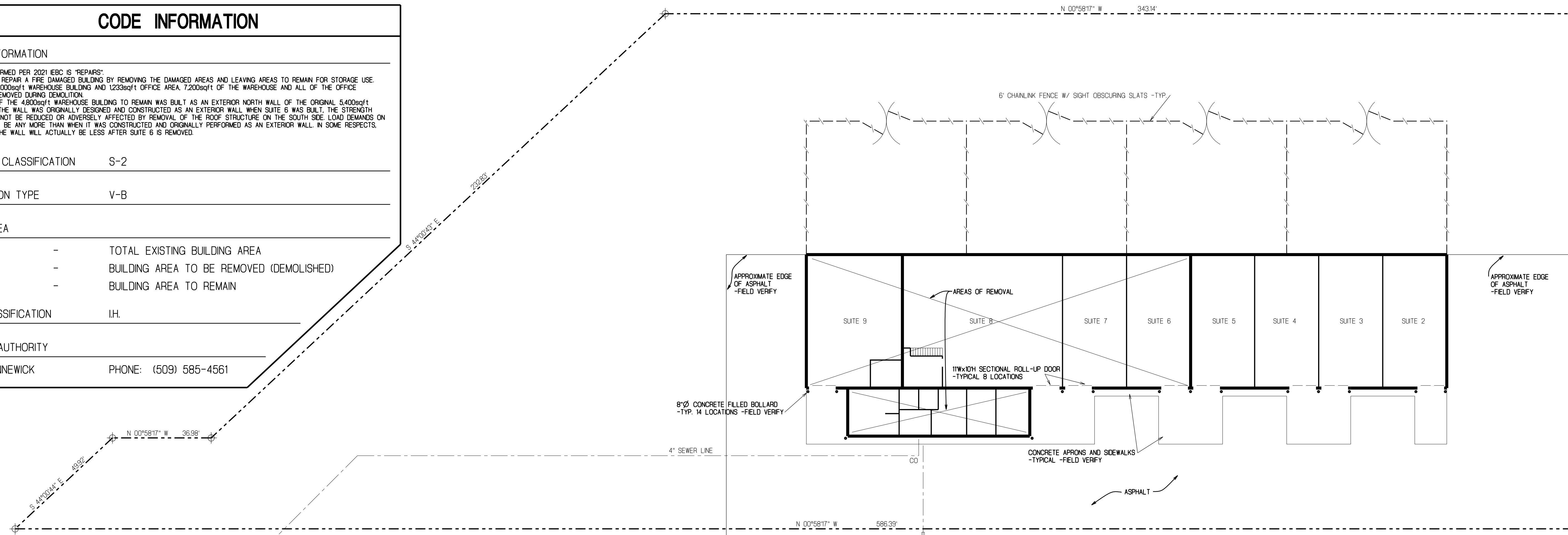

CALL U-DIG 811 BEFORE YOU DIG

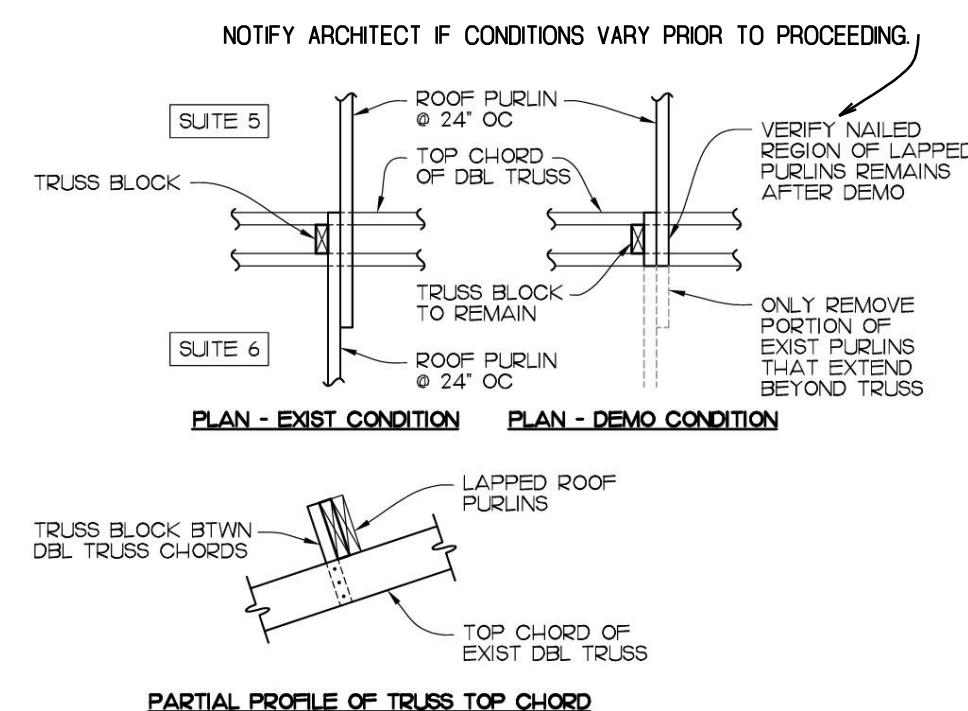

DRAWINGS INDEX

- A-1 EXISTING SITE PLAN, DEMOLITION AND CODE INFORMATION
- A-2 REVISED BUILDING PLAN & TECHNICAL SPECIFICATIONS
- A-3 EXTERIOR ELEVATIONS AND DETAILS
- R1 REFERENCE EXISTING BUILDING DRAWINGS
- M001 LEGENDS, SCHEDULES & NOTES
- M601 DEMOLITION AND SITE PLANS - HVAC
- E001 LEGENDS AND SCHEDULES
- E101 ELECTRICAL EXISTING SITE PLAN AND DEMOLITION PLAN

DESIGN TEAM

- CKJT ARCHITECTS - ARCHITECT
- CASEY ARCHITECTURAL SERVICES - CONSULTING ARCHITECT
- LSB - STRUCTURAL ENGINEERING
- L&S - MECHANICAL & ELECTRICAL ENGINEERING

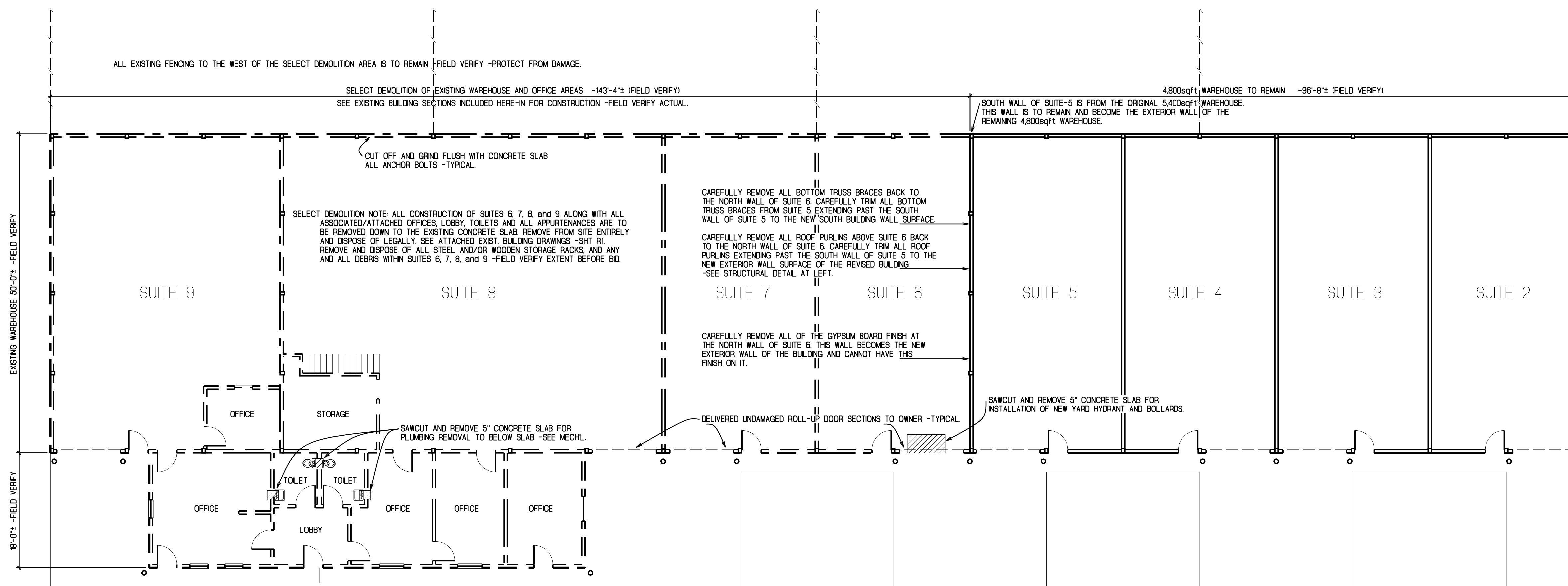

DEMOLITION PLAN

SCALE: 1" = 10'-0"

NOTE: PRE-DEMOLITION HAZARDOUS MATERIALS REPORT SEE PROCUREMENT AND CONTRACTING SPECIFICATIONS PER PORT OF KENNEWICK. CONDUCT LEAD-HANDLING AND OTHER HAZARDOUS MATERIALS REMOVAL ACTIVITIES IN ACCORDANCE WITH CURRENT APPLICABLE STATE AND FEDERAL REGULATIONS. A HAZARDOUS MATERIALS INSPECTIONS HAS BEEN CONDUCTED THROUGHOUT THE BUILDING. THE RESULTS OF THE INSPECTION ARE PROVIDED IN THE PRE-DEMOLITION HAZARDOUS MATERIALS INSPECTION REPORT, PREPARED BY PBS ENGINEERING AND ENVIRONMENTAL, DATED MAY 2024.

SEE MECHL AND ELECTRICAL DRAWINGS FOR ASPHALT AND CONCRETE REMOVAL REQUIRED FOR NEW WORK. ALL ASPHALT AND CONCRETE REMOVAL IS TO BE SAWCUT FULL DEPTH WITH A ROTARY BLADE PRIOR TO REMOVAL.

ckjt architects, pllc
 128 vista way
 kennewick, wa 98306
 509.783.6444

REGISTERED ARCHITECT
 Melissa Charlene McCoy
 STATE OF WASHINGTON
 2013432

date: 07-15-2024
 project no: 2403
 dra: [blank]
 check: [blank]
 approved: [blank]

EXISTING SITE PLAN, DEMOLITION PLAN and CODE INFORMATION
PORT of KENNEWICK's EAST 3rd STORAGE BLDG SELECT DEMOLITION
 1228 E. 3rd AVE, SUITES 6, 7, 8, and 9
 KENNEWICK, WASHINGTON

sht A1

of 3 sheets

exist site plan and demo plan
 date 07-15-2024

PROJECT TECHNICAL SPECIFICATIONS

SECTION 05 50 00 MISCELLANEOUS METAL FABRICATIONS

PART 1/GENERAL
101 WORK INCLUDED
 Include all labor, materials, equipment, transportation, and services required to complete all miscellaneous metal fabrications as shown on the drawings and/or herein specified.
102 SUBMITTALS
 Provide shop drawings for all metal fabrications. Field verify all existing dimensions prior to producing shop drawings as required.
PART 2/PRODUCTS
201 MATERIALS
A. STRUCTURAL SHAPES
 ASTM A36, Fy = 36KSI
B. PIPE
 ASTM A53, standard except where otherwise noted
C. SHEET, PLATE AND BARS
 ASTM A36
D. TUBING
 ASTM A500, Grade B, Fy = 46KSI
E. RODS
 ASTM A36
F. ANGLE, CHANNEL AND TIES
 ASTM A36
G. BOLTS
 ASTM 305-N, ASTM 307 and ASTM A325-SC
H. WELD STUDS
 Headed - Nelson S3L and H4L
 Threaded - Nelson CP, and Nelson D2L
I. ADHESIVE ANCHORS
 Adhesive Anchors (AA) in Concrete ASTM A307, Grade C threaded rod with Simpson SET-XP adhesive or Hill H45-E threaded rod or Grade C threaded rod with HIT-HY 200 adhesive or approved equal. Concrete to have aged a minimum of 21 days prior to installation. Sizes as noted on the drawings. Lengths as required for conditions of installation in each case.
J. MISCELLANEOUS MATERIALS
 See Drawings
202 FABRICATION
A. BOLLARDS
 Fabricate from pipe, flat plate and weld studs as shown.
B. BOLTED FENCE BASE PLATES
 Fabricate from flat plate as shown.
203 COORDINATION
 Coordinate fabrication and erection with work of other trades. No distortion or cutting of any structural members for accommodation of other trades will be permitted except as shown or approved.
204 FABRICATION
 Verify dimensions, positioning and point of attachment. Fabricate accurately and neatly from approved shop drawings to provide workmanlike installation of adequate strength and fit; fabricate to size and detail. Gauges and weights shown are minimums.
205 SHOP PAINTING
 Remove loose mill scale, flake, rust, oil, weld spatter or other foreign material. Apply one full shop coat to all surfaces, except galvanized materials and areas to be field welded or embedded in concrete; apply one field coat of same primer to abraded areas and field connections.
PART 3/EXECUTION
301 FABRICATION OF STEEL
 Form to accurate sizes and shapes, with sharp lines and angles. Punch and shear to leave clean surfaces. Weld or rivet permanent connections; grind and sand exposed welds smooth. Do not use screws or bolts where they can be avoided. Use used, countersink heads and draw tight; nick threads to prevent loosening. Provide holes and connections for work of other trades. Apply body filler as required to provide neat, smooth, clean appearance on exposed steel work of all types.
302 INSTALLATION
 Provide all required bolted connection components. Install as per drawings and approved shop drawings. Provide galvanized at all exterior locations.
END OF SECTION 05 50 00

SECTION 07 60 00 FLASHING & SHEET METAL

PART 1/GENERAL
101 WORK INCLUDED
 Include all labor, materials, equipment, transportation, and services required to complete the flashing and sheet metal work as shown on the drawings and/or herein specified.
102 SUBMITTALS
 Furnish complete detailed shop drawings for approval prior to fabrication. Submit color samples for selection prior to ordering.
103 ELECTRICAL ACTION
 Where aluminum is to be in contact with dissimilar materials, treat contact surfaces to prevent electrolysis.
PART 2/PRODUCTS
201 PRODUCTS
A. FABRICATED SHEET METAL FLASHING
1. GENERAL
 Best commercial quality, thickness not less than specified below or shown on the drawings. Use heavier gauges where called for in item specification or where noted on the drawings.
2. Galvanized Steel-Plan
 24-gauge copper-bearing base metal, commercial-weight zinc coating, unless noted otherwise on the drawings.
3. Fasteners
 Hot-dipped galvanized steel fasteners with neoprene washers where indicated on the drawings. Color to match flashing.
B. COLLARS & FINISHES
 All flashing and sheet metal shall be pre-finished utilizing a two-coat system comprised of Kynar 500 and Hydr 5000 unless noted otherwise herein.
 Colors to be selected by Architect from manufacturer's standard colors.
C. ACCESSORIES
 See drawings, and as required for weather-tight installation.
202 WORKMANSHIP
A. PREPARATION
 Put surfaces to be covered with sheet metal in proper conditions for covering.
 Contractor responsible for defective work from any cause, including improperly prepared surfaces.
B. GENERAL
 Form materials accurately to shapes and dimensions indicated, with lines and angles in true alignment, without waves or buckles. Make proper allowance for expansion and contraction. Make exterior work permanently weather-tight.
PART 3/EXECUTION
301 FABRICATED SHEET METAL FLASHING
 Fabricate from galvanized steel as detailed on the drawings and noted herein.
 Provide expansion joints between sections. Install all sheet metal work to exclude water.
 Fabrication and installation to comply with SMACNA Standards.
END OF SECTION 07 60 00

SECTION 13 12 00 METAL WALL PANEL

PART 1/GENERAL
101 WORK INCLUDED
 Include all labor, materials, equipment, transportation, and services required to furnish and install the metal building wall panels as shown on the drawings and/or herein specified.
102 WALL PANEL TYPE
 Building wall panels to match existing -field verify.
103 SUBMITTALS
A. PRODUCT DATA
 Submit manufacturer's catalog cuts and data sheets for all items being supplied for approval.
B. SAMPLES
 Submit 12" long samples of wall panel materials. Architect's review will be for color and texture only.
104 DELIVERY, STORAGE AND HANDLING
A. DELIVERY
 Deliver panels, trim, flashing, accessories, and erection hardware in building manufacturer's unopened packs and containers identified with building manufacturer's name and contents of each carton or pack.
B. STORAGE
 Stack materials on platforms or pallets, covered with tarpaulin or other suitable weather-tight, ventilated covering. Store metal sheets on panels so that weather accumulations will drain freely. Do not store sheets or panels in contact with other materials which might cause staining.
C. HANDLING
 Handle material properly to protect from damage.
PART 2/PRODUCTS
201 MANUFACTURER
 MFCI R-Panel or approved -Match Existing Profile -Field Verify Prior to Bid
202 MATERIALS (GENERAL)
A. METALS
 Galvanized Steel Sheet
 Comply with the requirements of ASTM A446 with G90 coatings. "Class" to suit building manufacturer's standards.
B. SHOP PRIMER FOR GALVANIZED MEMBERS
 Provide manufacturer's standard zinc dust-zinc oxide primer selected for compatibility with substrate. Comply with performance requirements of FS T1-P-641
C. SHOP PRIMER METAL SURFACES
 Provide manufacturer's standard flat, lusterless alkyl enamel. Comply with the performance requirements of FS T1-E-527.

Cont. -SECTION 13 12 00

203 WALL PANELS
A. WALL PANELS (Match Existing Profile -Field Verify Prior to Bid)
 Siding panels shall be 24 gauge precision roll-formed. The panels shall have 125" high major ribs 12" o.c. with two minor ribs symmetrically spaced between the major ribs to provide 35% net coverage. 50,000 psi minimum yield steel. Panel sidings shall be formed by lagging major ribs at the panel edges. The underlapping ribs shall have full bearing legs to support the siding. Panels shall be longest length possible to minimize endlaps. Panel endlaps (when required) shall be over a structural member and shall be a 4" minimum lap. Corner trim, base trim and transition flashings shall be provided as required to complete the wall assembly. Closures and fasteners shall be provided as required for a weathertight installation. Fastener spacing and type to be determined by manufacturer's standard offering.
B. PANEL FINISH
 Manufacturer's standard G5 or per sq. ft. aluminum-zinc alloy-coating with Kynar 500 or Hydr 5000 finish coat. Color to be selected from manufacturer's full range of colors.
C. ACCESSORIES
 Provide manufacturer's standard clips, fasteners, sealant, and connection hardware.
D. FASTENERS
 Manufacturer's standard long-life coated #12-14 x 0.875" self-drilling carbon steel screws for liner panels and/or exterior single skin wall panels, and #12-14 x 1.25" self-drilling carbon steel screws for exterior single skin wall panels utilizing thermal insulation up to 4" thick. All exposed fastener heads will be factory colored to match color of panels.
 Trim Fasteners: Manufacturer's standard plated and finish painted #8 x 0.625" self-drilling screws with 0.25" hex washer head.
PART 3/EXECUTION
301 WALL PANELS
A. GENERAL
 Install wall panels with vertical edges plumb. Arrange and nest sidelp joints away from prevailing winds when possible.
 Apply panels and associated items for neat and weathertight enclosure. Avoid "panel creep" or application not true to grid lines.
 Protect factory finishes from mechanical damage or abrasions. Install approved type closures to exclude weather.
 Flash and/or seal wall and liner panels at perimeter of all openings, under eaves and gable trims, along lower panel edges, and elsewhere as required or shown on drawings, as applicable. Remove all fastener or cut shavings from wall as erection is completed.
B. WALL PANELS
 Install wall panels at locations as shown on drawings.
 Align bottom of panels to proper coverage and fasten with manufacturer's recommended and supplied fasteners.
 Cut and fasten flashing and trims with approved type fasteners.
 Install all fasteners with power tool having adequate torque and proper rpm adjusted to seat fastener without damage to heads, washers, or panels. Install panels sidelp away from prevailing and or view direction when possible, maintaining proper lap without fastener dimpling or excessive overlap.
302 PANEL DAMAGE AND FINISH SCRATCHES
 Touch-up all abrasions, scratches, field welds or other damages in shop-coat or factory-finished painted surfaces consistent with shop coat, or factory-finished painting.
END OF SECTION 13 12 00

SECTION 32 31 00 CHAINLINK FENCE

PART 1/GENERAL
101 WORK INCLUDED
 Include all labor, equipment, materials, transportation, and services required to complete the chain link fencing work as shown on the drawings and/or herein specified.
102 SUBMITTALS
 Submit gate shop drawings, manufacturer's specification sheets for all fence system components, and slot coat samples for approval prior to ordering.
103 REFERENCES
A. ASTM A 116 - Standard Specification for Zinc-Coated (Galvanized) Steel Woven Wire Fence Fabric, 1995
B. ASTM A 123/A 123M - Standard Specification for Zinc (Hot-Dip Galvanized) Coatings on Iron and Steel Products, 2000
C. ASTM A 302/A 302M - Standard Specification for Zinc-Coated (Galvanized) Steel Chain-Link Fence Fabric, 2000
D. ASTM A 392 - Standard Specification for Zinc-Coated Steel Chain-Link Fence Fabric, 1996
E. ASTM F 857 - Standard Practice for Installation of Chain-Link Fence, 2000
F. ASTM 900 - Standard Specifications for Industrial and Commercial Swing and Rolling Gates
G. ASTM F 1043 - Standard Specifications for Strength and Protective Coatings on Metal Industrial Chain Link Fence Framework
H. ASTM F 1083 - Standard Specification for Pipe, Steel, Hot-Dipped Zinc-Coated (Galvanized) Welded, for Fence Structures, 1997
I. CLPM CLF 2445 - Product Manual, Chain Link Fence Manufacturers Institute, 1997
PART 2/PRODUCTS
201 GENERAL
 The following fence types are required -
 - 4" high, galvanized with site obscuring slats.
202 FENCE SYSTEM - GALVANIZED
A. GENERAL
 Posts, gate frames, braces, rails, stretcher bars, truss rods and tension wire shall be of steel. Gate hinges, post caps, stretcher bar bonds, and other parts shall be of steel, malleable iron, or ductile iron.
B. INTERMEDIATE POSTS
 1 1/2" O.D. hot dipped Schedule 40 pipe, 272 lb. per L.F., ASTM F-1083.
C. TERMINAL POSTS
 End corner and pull posts shall be 2 3/8" O.D. hot dipped Schedule 40 pipe, 365 lb. per L.F., ASTM F-1083.
D. SWING GATE POSTS
 Gate posts to be 6" O.D. hot dipped schedule 40 pipe, 91 lb. per L.F., ASTM F-1083.

Cont. -SECTION 32 31 00

E. SWING GATE FRAMES
 1 1/2" O.D. hot dipped Schedule 40 pipe, 272 lbs. per L.F., ASTM F-1083. Gates over 8' wide shall be 1 3/4" O.D. Hot dipped Schedule 40 pipe, 272 lb. per L.F.
F. RAILS & POSTS BRACES
 1 1/2" O.D. hot dipped Schedule 40 pipe, 272lb. per L.F., ASTM F-1083.
G. WIRE FABRIC - TYPICAL
 Standard vinyl sight obscuring slats. Color to match existing -field verify. Slats are required at all fencing shown on the drawings -see plans.
H. TENSION WIRE
 7 gauge, galvanized, single strand, finish to match fabric.
I. TIE
 Aluminum alloy steel wire, 9-gauge or 11-gauge, galvanized steel, to match fabric core material.
J. GATE KEEPERS
 1 1/2" O.D. hot dipped Schedule 40 pipe with gate keeper and locking chain attached.
K. OPTIONAL STANDARD
 Pipe products conforming to ASTM F1043 Material Group 1C are approved for items B, C, D, E, and F.
L. GATE LATCHES, STOPS AND HINGES
 Hot dipped galvanized.
M. SLATS
 Standard vinyl sight obscuring slats. Color to match existing -field verify. Slats are required at all fencing shown on the drawings -see plans.
PART 3/EXECUTION
301 GENERAL
 Installation of fencing shall meet the requirements of ASTM F-567. Install wire fabric with knuckled edge at top of fence at all locations.
302 FENCE POSTS
 Posts shall be set in concrete and bolted to existing concrete slabs as shown on the drawings. Maximum 10' on center spacing, unless shown otherwise on the drawings.
303 SWING GATES
 Gates shall be complete with latches, padlock fittings, stops and keepers. Swing gates shall conform to ASTM F-900 and have hinges.
 The gate frames shall be constructed of tubular members welded at all corners or assembled with fittings. On steel welds shall be painted with zinc-based paint. Gates shall have truss rods of 5/16-inch minimum nominal diameter to prevent sag or twist.
 Gate fabric shall be the same type as used in the fence construction. The fabric shall be attached securely to the gate frame at intervals not exceeding 15 inches.
 Gate hinges shall be of adequate strength for gates, and with large bearing surfaces for clamping in position. The hinges shall not twist or turn under the action of the gate. The gates shall be capable of being opened and closed easily by one person. Gates shall be non-removable.
 Gate latches, stops and keepers shall be provided for all swing gates. Single gates of opening less than 10 feet wide, are to have a forked latch.
 Latches shall be arranged for locking. No stop is required for single gates. Keepers shall consist of a mechanical device for securing the free end of the gate when in the full open position. Padlock locking assemblies are required on all gates.
304 POST TOPS
 Shall consist of ornamental tops. The top shall be provided with a hole suitable for the through passage of the top rail. The post tops shall fit over the outside of posts and shall exclude moisture from posts.
 End and corner posts shall have domed metal tops.
305 TOP RAILS
 Shall be 1 1/2" lengths not less than 18 feet, and shall be fitted with couplings or wedged for connecting the lengths into a continuous run. The couplings shall be not less than 6 inches long, with 0/70 minimum wall thicknesses, and shall allow for expansion and contraction of the rail. Suitable ties or clips shall be provided in sufficient number for attaching the fabric securely to the top rail at intervals not exceeding 2 feet. Means shall be provided for attaching the top rail to each gate, corner, pull end and post.
306 TENSION BARS
 Shall not be less than 3/16 by 3/4-inch and not less than 2 inches shorter than the normal height of the fabric with which they are to be used. One tension bar shall be provided for each end and gate-post, and two for each corner and pull post.
307 FABRIC AND TIES OR CLIPS
 Ties or clips of adequate strength shall be provided in sufficient number for attaching the fabric and stretcher bars to all terminal posts at intervals not exceeding 15 inches. Tension bands shall be formed from flat or beveled steel and shall have a minimum thickness after galvanizing of 0.078 inch and minimum width of 7/8-inch for posts larger than 4" O.D. Brace bands shall be formed from flat or beveled steel and shall have a minimum thickness of 0.083 inch after galvanizing and a minimum width of 3/4 inch for post 4" O.D. Standard mill tolerances of + 0.005 inch on thickness and 0.010 inch on width shall apply. Attachment bolts shall be 5/16 x 1-1/4-inch galvanized carriage bolts with nuts. Attach fabric per industry standards.
308 SLATS
 Install continuous line of sight obscuring slats in all fence panels and gates.
309 CLEAN-UP
 Remove all debris from fence erection from site. No installer's signs allowed to remain on any fence.
 Remove all concrete from exposed portions of posts.
END OF SECTION 32 31 00

ckjt architects, pllc
 5097853444
 KENNEWICK, WA 98036
 128 163rd way

REGISTERED ARCHITECT
 Melissa Charlene McCoy
 STATE OF WASHINGTON
 20173432

date: 08-29-24
 project no: 2403
 d'rawn: [blank]
 checked: [blank]
 approved: [blank]

REVISED BUILDING PLAN & TECHNICAL SPECIFICATIONS
PORT of KENNEWICK's EAST 3rd STORAGE BLDG SELECT DEMOLITION
 1228 E. 3rd Ave, SUITES 6, 7, 8, and 9
 KENNEWICK, WASHINGTON

sht A2
 of 3 sheets

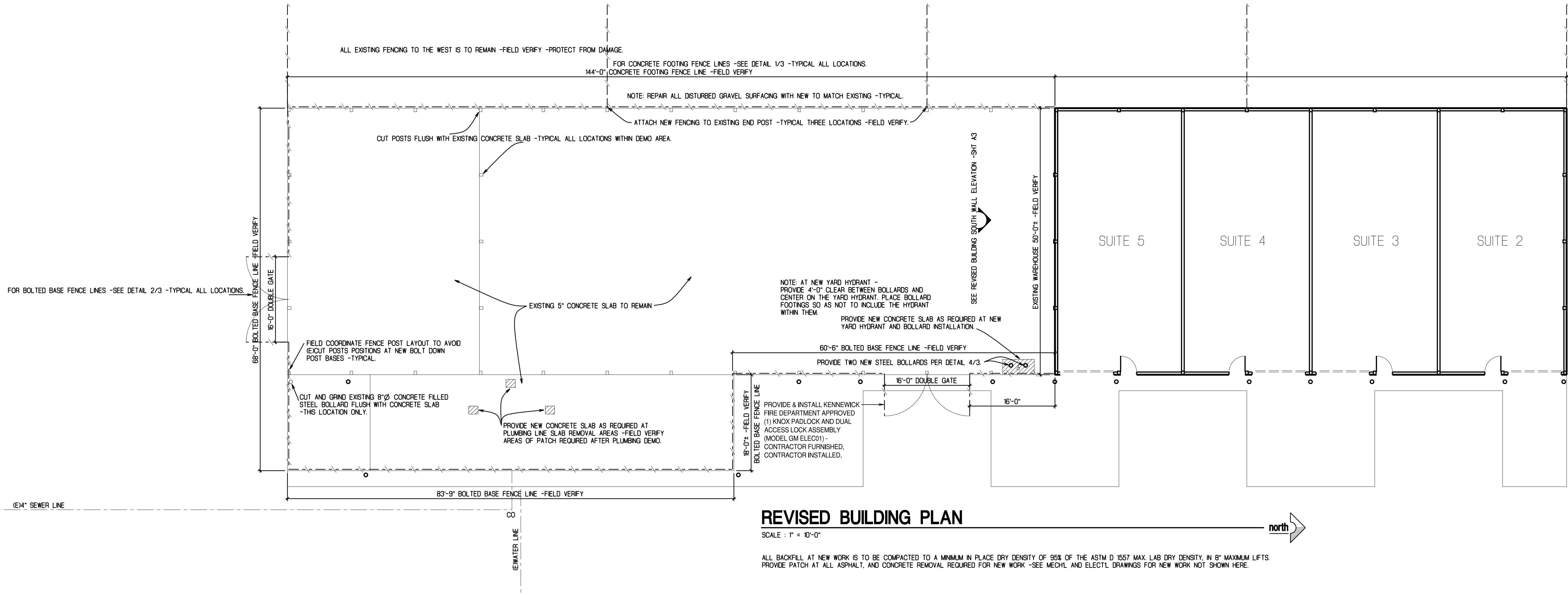

REVISED BUILDING PLAN

SCALE: 1" = 10'-0"

ALL BACKFILL AT NEW WORK IS TO BE COMPACTED TO A MINIMUM IN PLACE DRY DENSITY OF 95% OF THE ASTM D 1557 MAX. LAB DRY DENSITY, IN 8" MAXIMUM LFTS. PROVIDE PATCH AT ALL ASPHALT, AND CONCRETE REMOVAL, REQUIRED FOR NEW WORK -SEE MECH. AND ELECTR. DRAWINGS FOR NEW WORK NOT SHOWN HERE.

revised: [blank]
 date: 08-29-2024

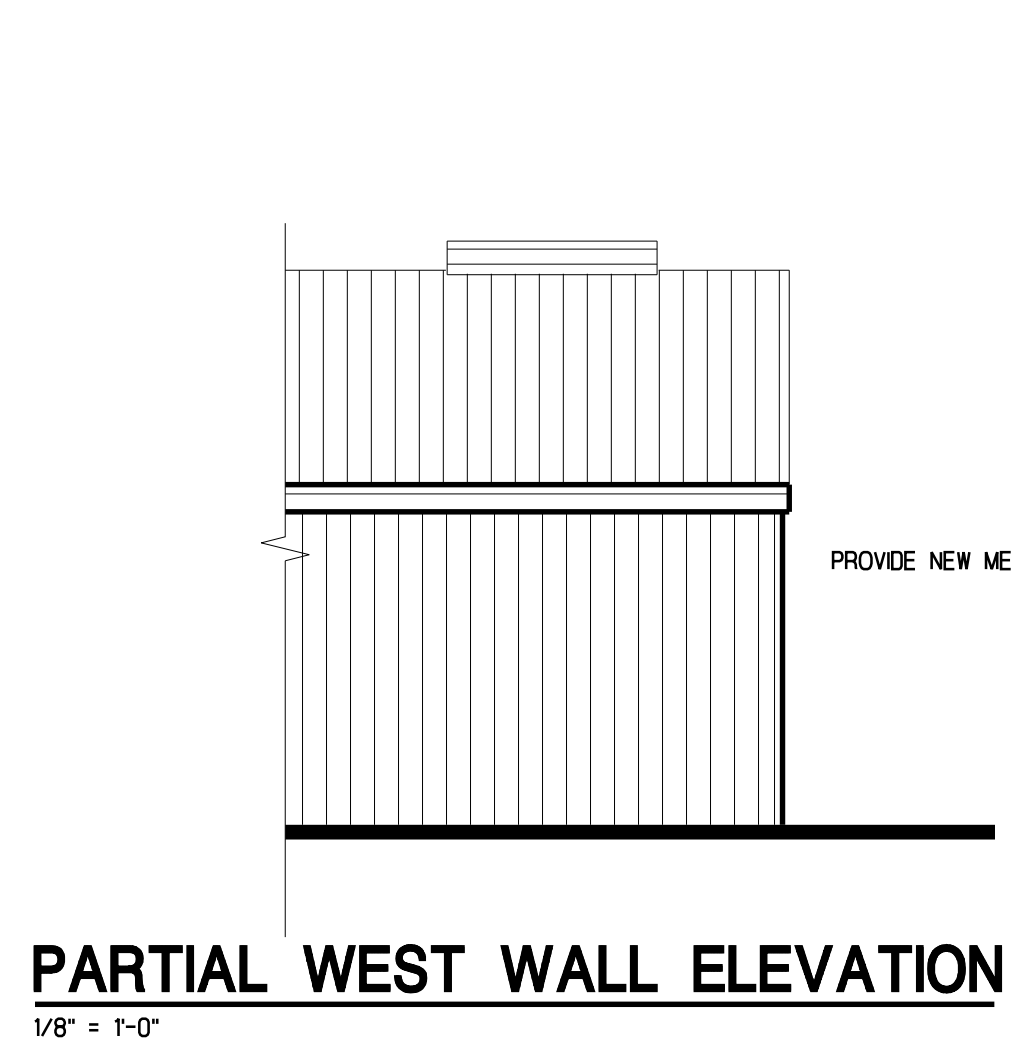

1/8" = 1'-0"

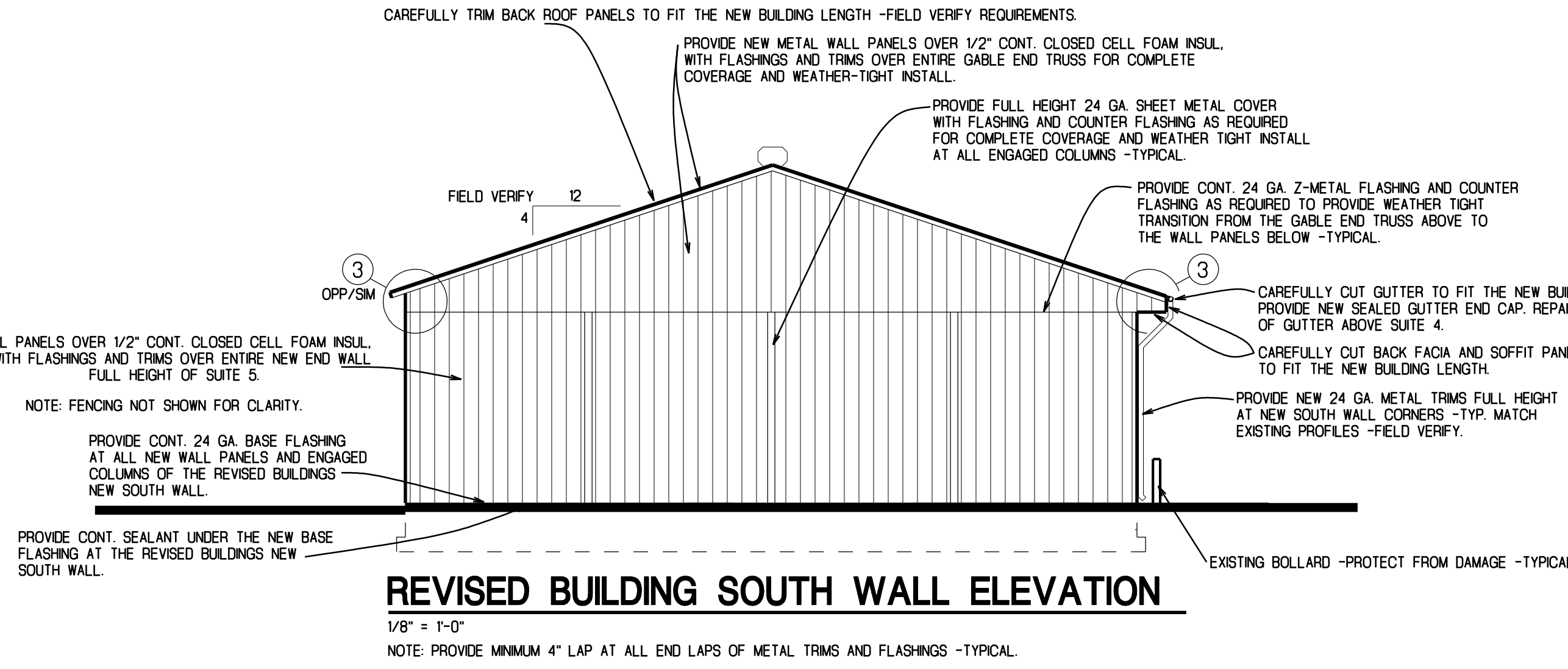

REVISED BUILDING SOUTH WALL ELEVATION

1/8" = 1'-0"
NOTE: PROVIDE MINIMUM 4" LAP AT ALL END LAPS OF METAL TRIMS AND FLASHINGS -TYPICAL.

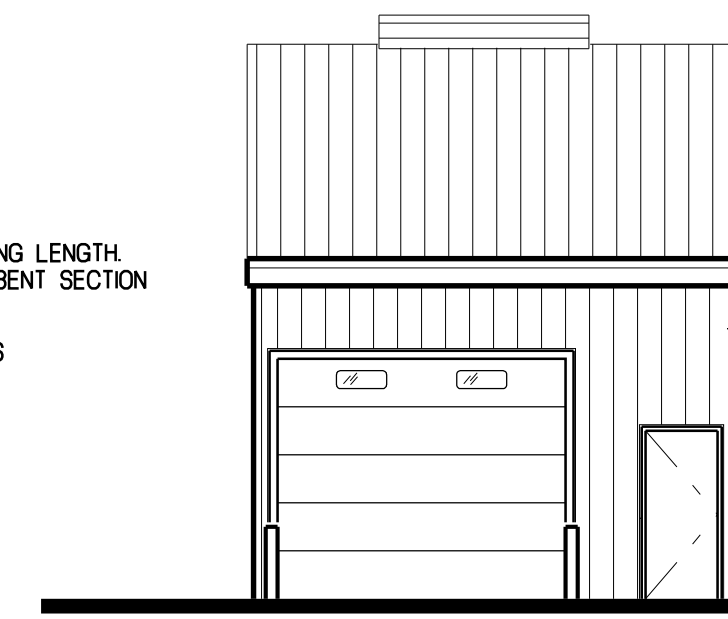

PARTIAL EAST WALL ELEVATION

1/8" = 1'-0"

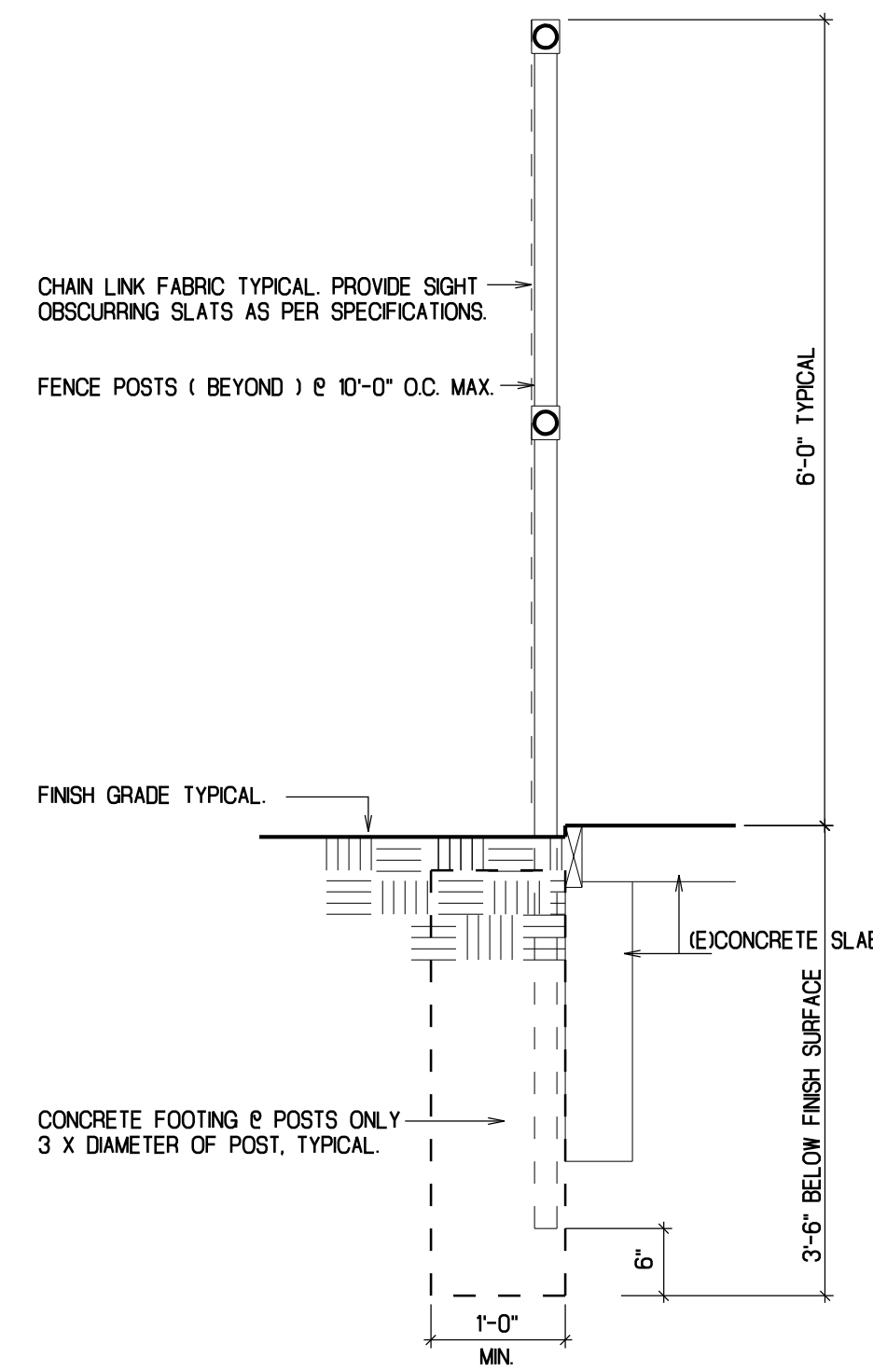

1 FENCE POSTS WITH CONCRETE FOOTING
SCALE: 3/4" = 1'-0"

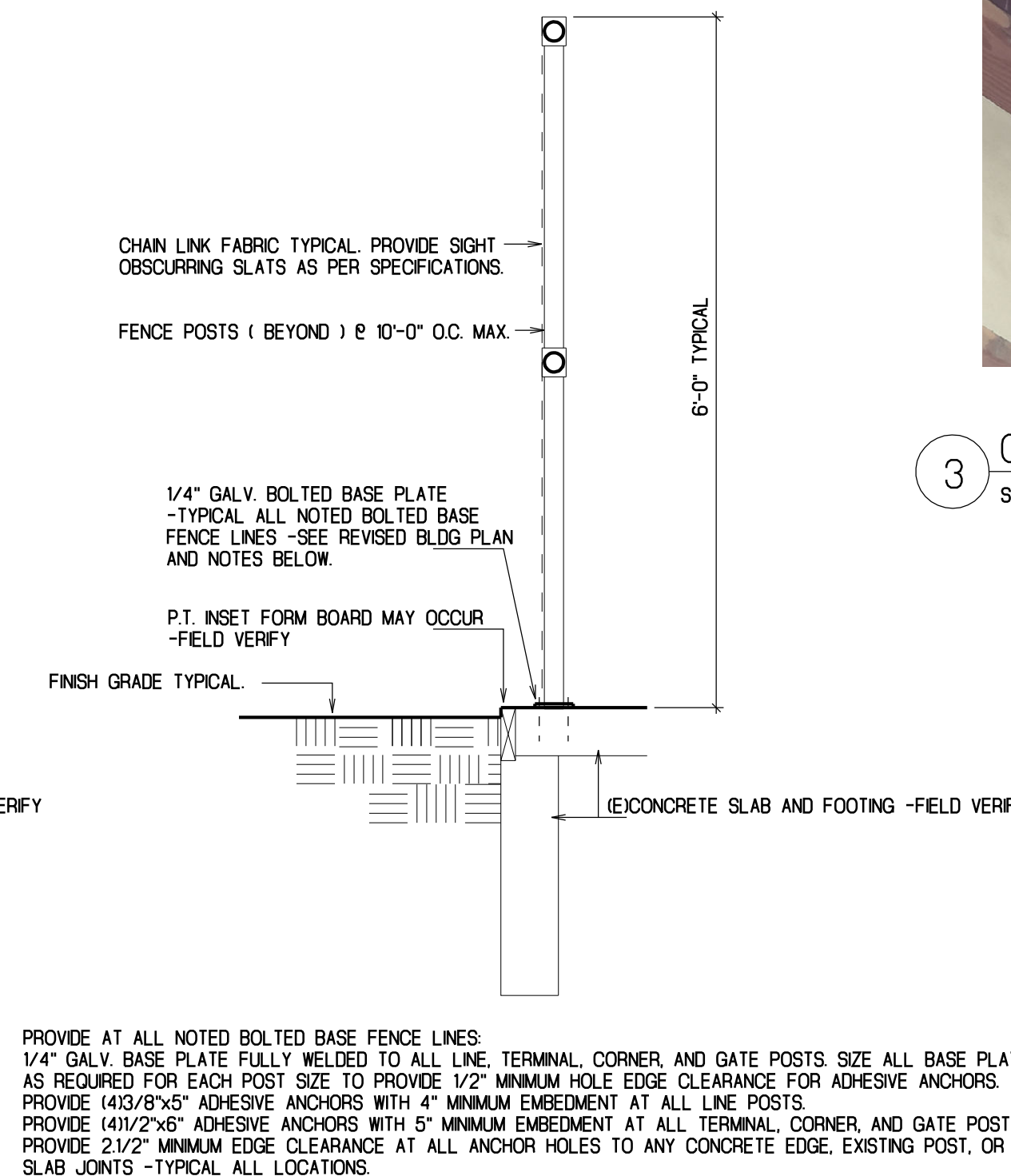

2 FENCE POSTS WITH BOLTED BASE PLATES
SCALE: 3/4" = 1'-0"



3 GABLE END CORNER DETAIL
SCALE: 3/4" = 1'-0"

AFTER REMOVAL OF SUITE-6 CUT BOLTS FLUSH WITH THE NUTS AND PROVIDE BUILD-UP AT BOTH BOLTINGS AND STRAP IN ORDER TO COVER BOTH WITH NEW WALL PANELS, FLASHINGS AND TRIMS. FIELD DETERMINE FINAL CONFIGURATION. GET APPROVAL FROM ARCHITECT OF CONFIGURATION PRIOR TO COVERING WITH METAL.

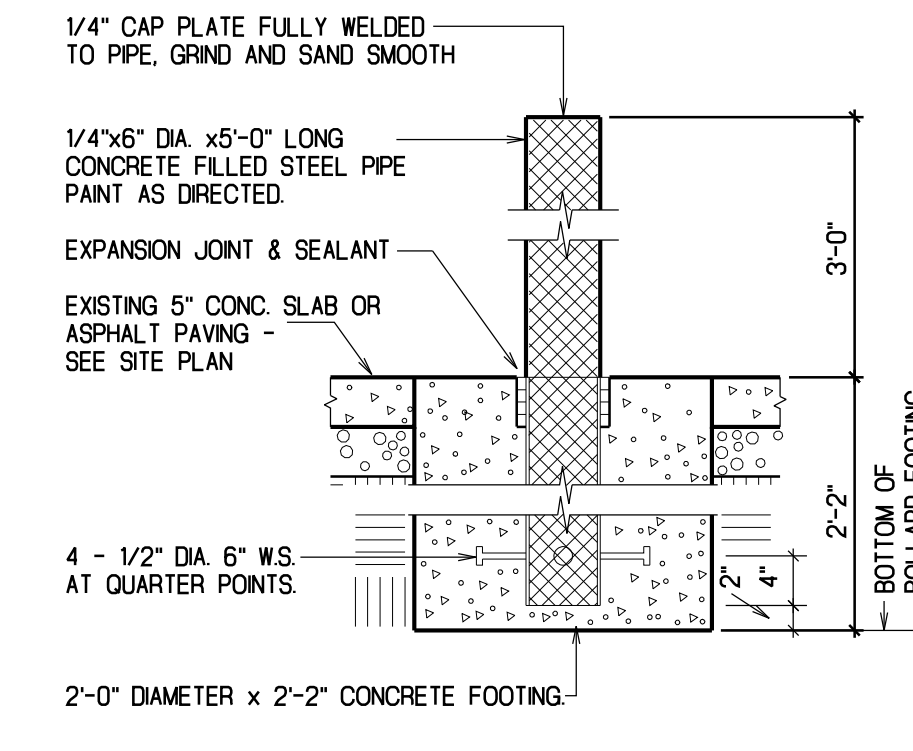

4 TYPICAL BOLLARD DETAIL
NOT TO SCALE

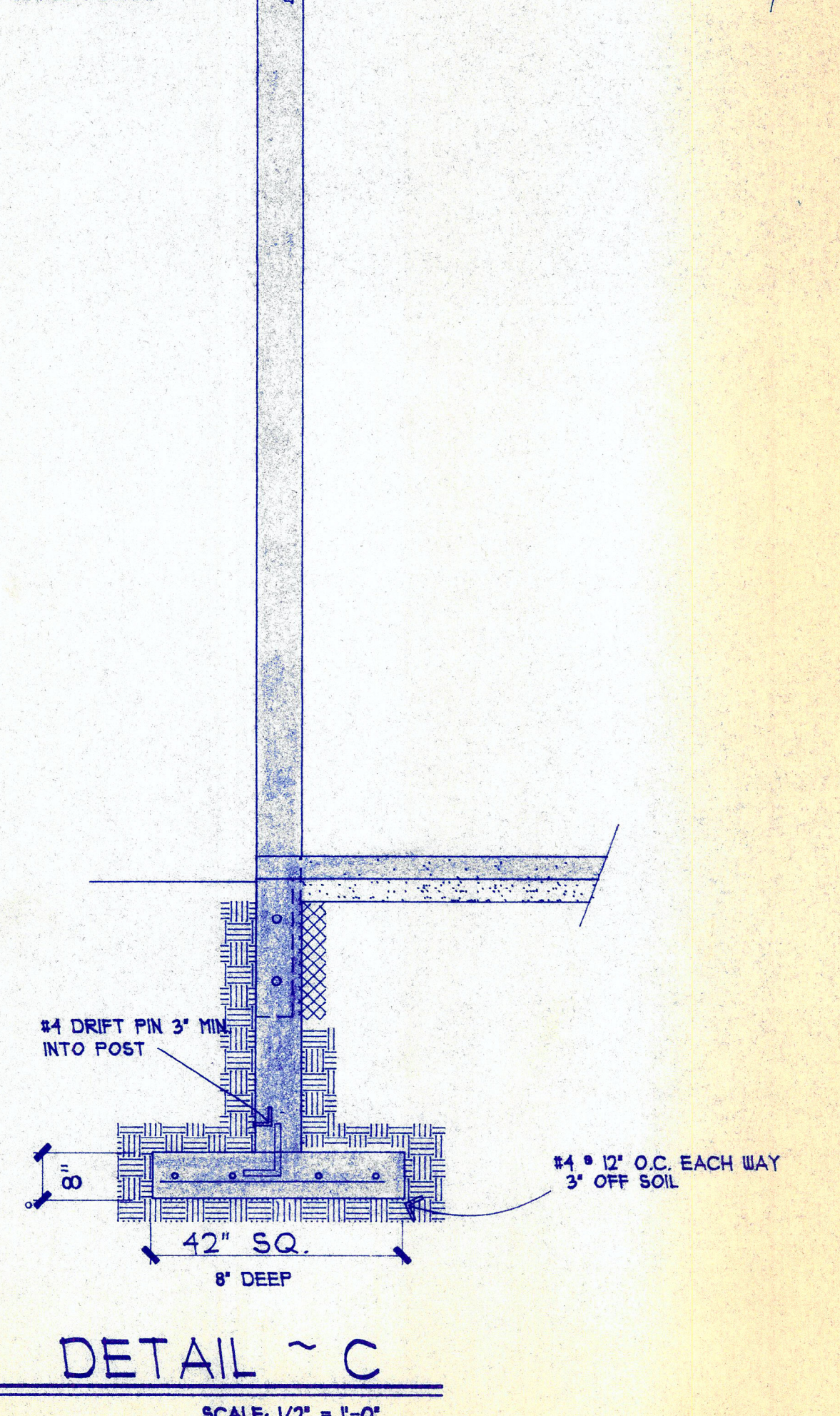
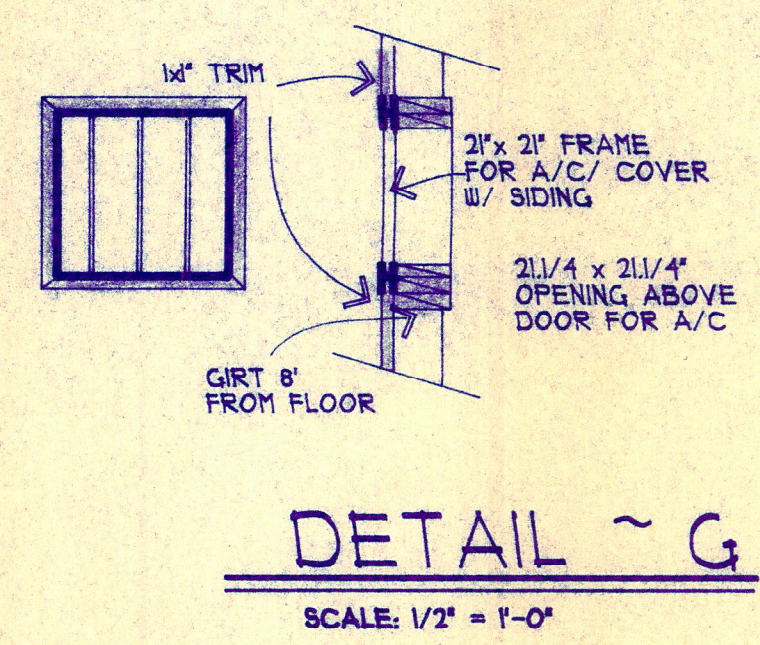
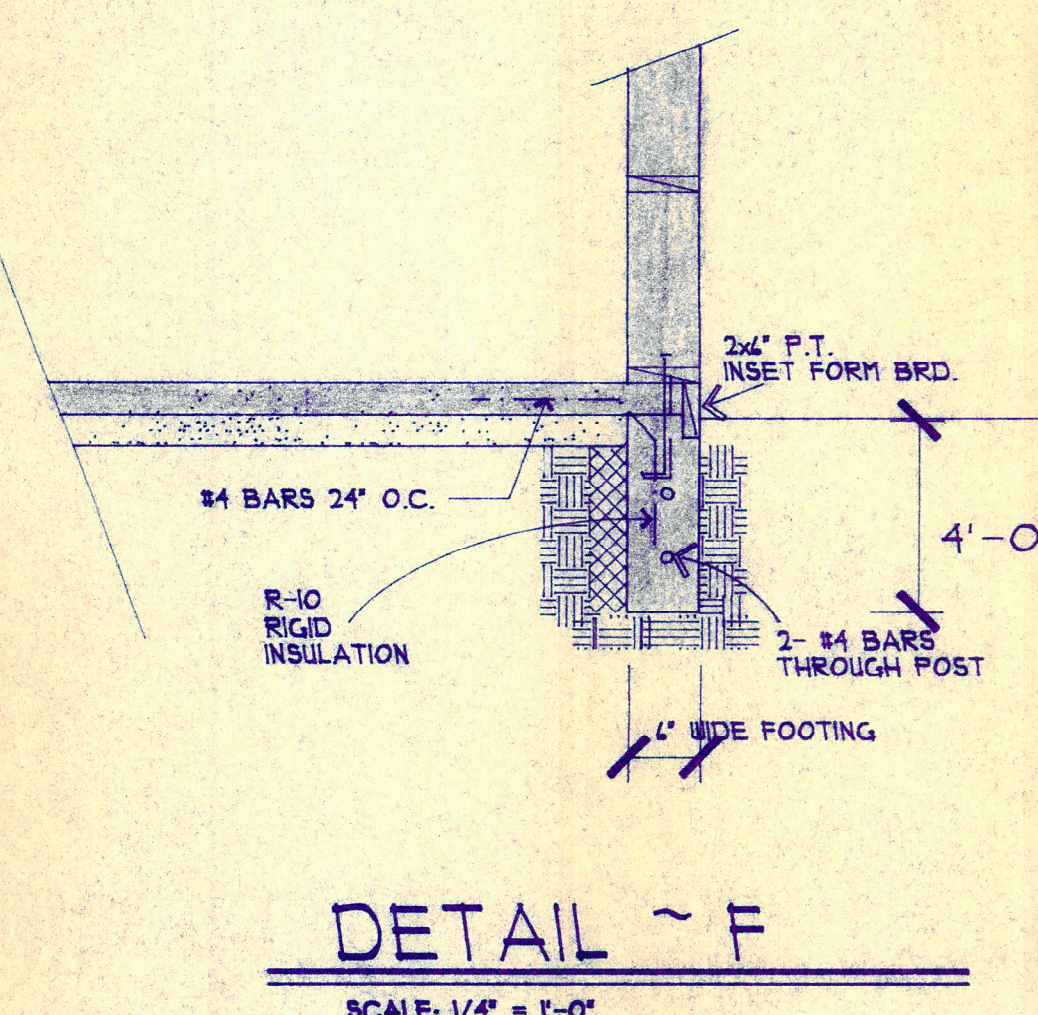
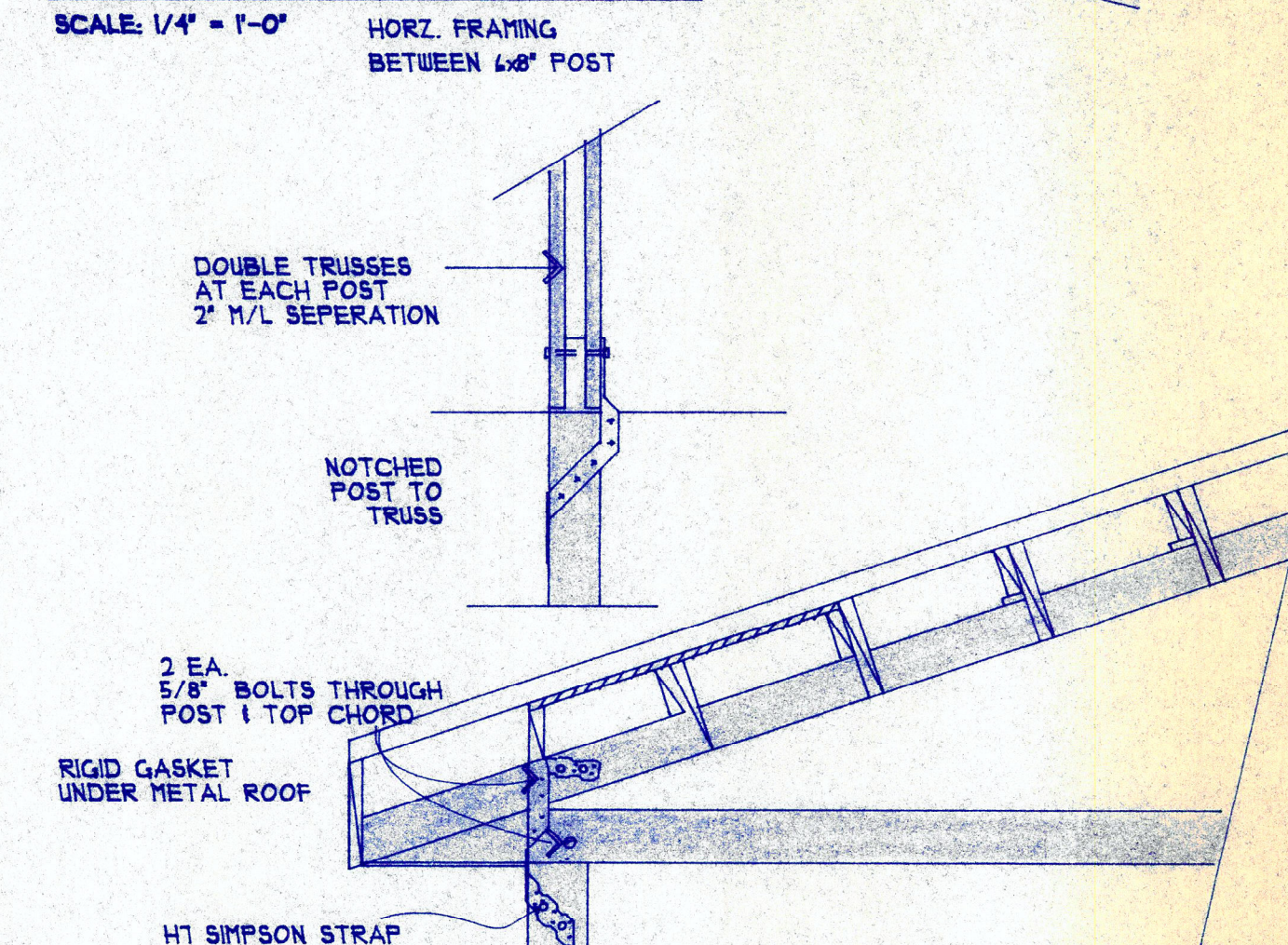
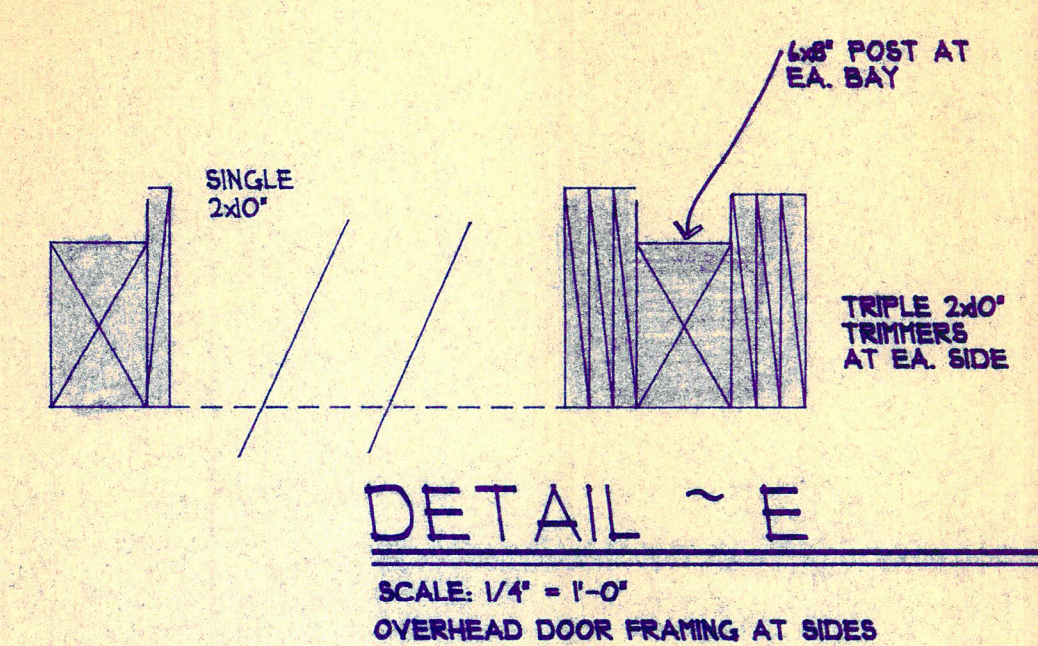
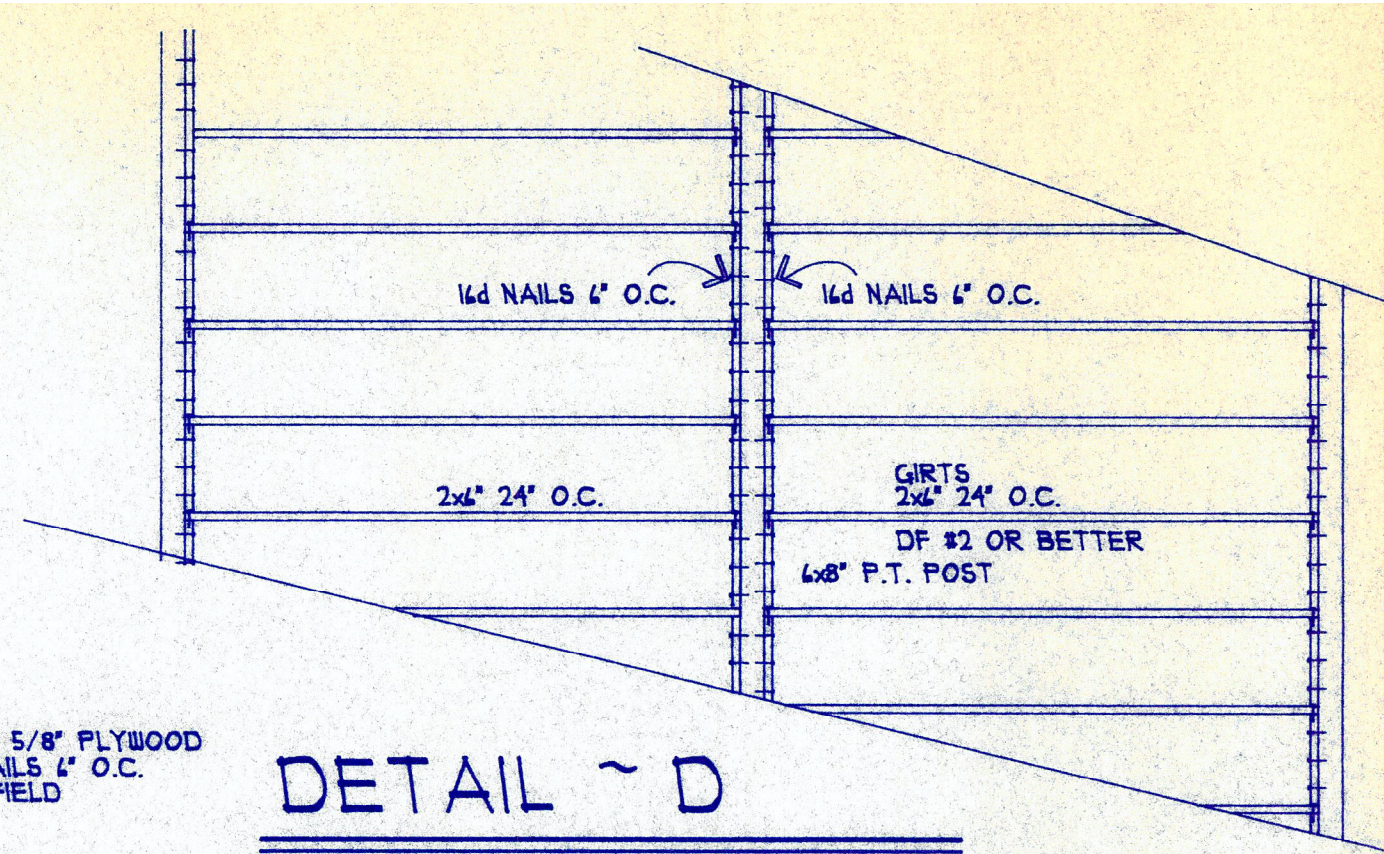
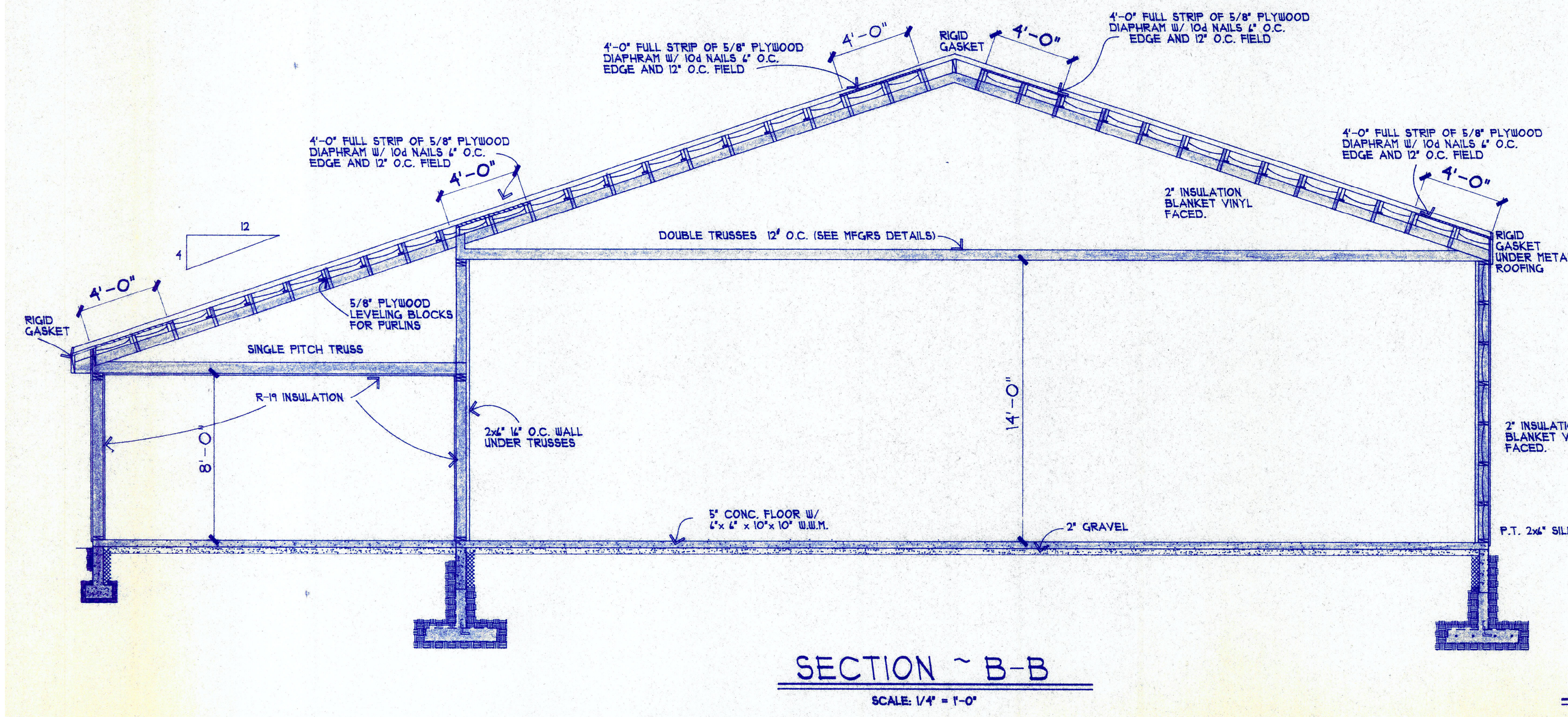
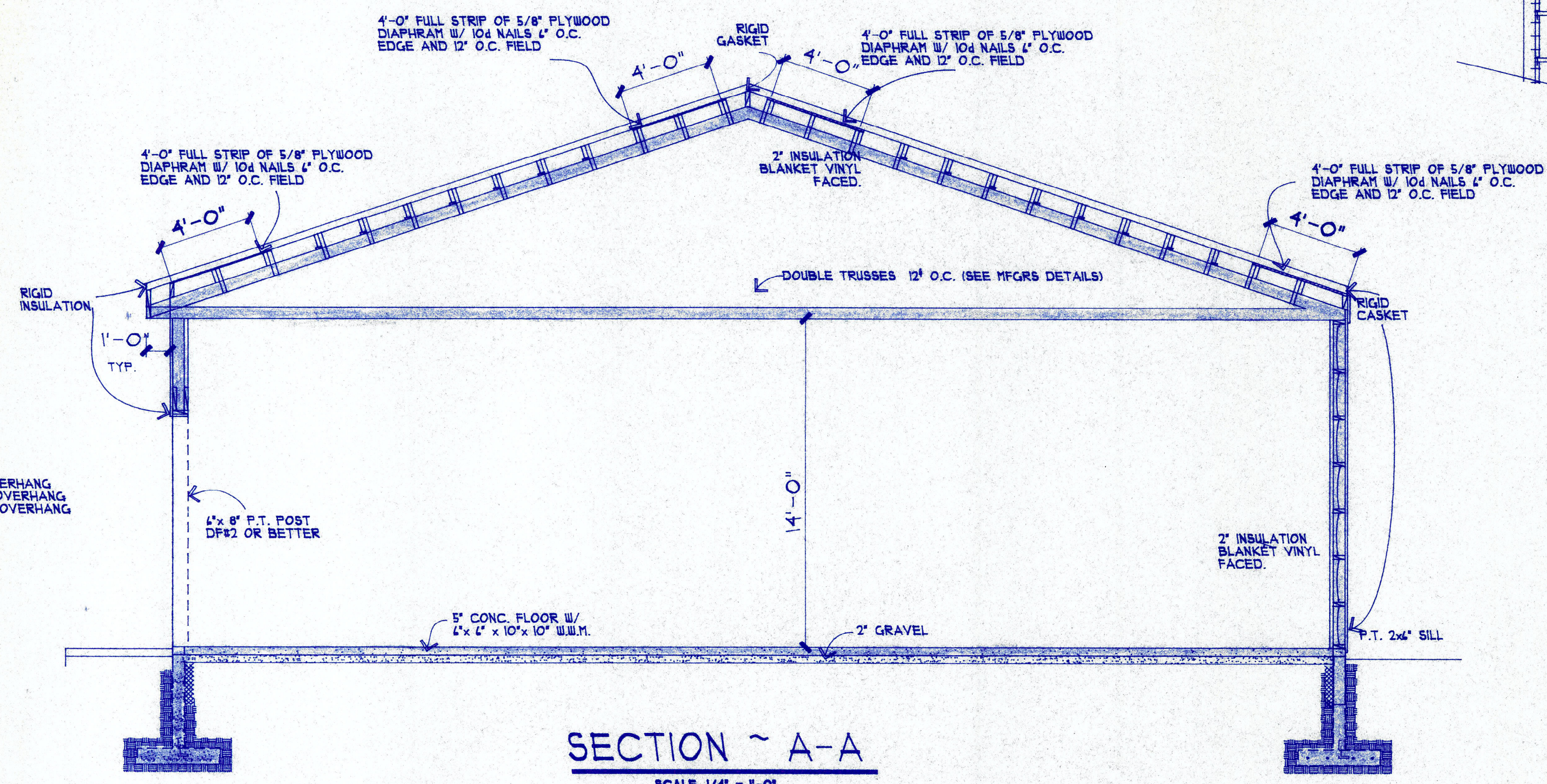

EXISTING BUILDING SECTIONS
PROVIDED FOR REFERENCE ONLY - FIELD VERIFY EXISTING AS-BUILT CONDITIONS

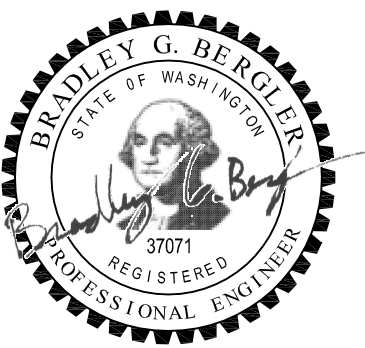

07/15/24

date: 07-15-24
 project no. 2403
 draw: JME
 check: BGB
 approved: BGB

LEGENDS SCHEDULES & NOTES
PORT of KENNEWICK's EAST 3rd STORAGE BLDG SELECT DEMOLITION
 1328 E. 3rd AVE, SUITES 6, 7, 8, and 9
 KENNEWICK, WASHINGTON

GENERAL CODE NOTES	
1. COMPLY WITH THE CURRENT INTERNATIONAL COMMERCIAL CODE (ICC), INTERNATIONAL BUILDING CODE (IBC), INTERNATIONAL MECHANICAL CODE (IMC), UNIFORM PLUMBING CODE (UPC), INTERNATIONAL FIRE CODE (IFC), WASHINGTON STATE ENERGY CODE (WSEC), AND ALL APPLICABLE STATE AND LOCAL CODES AND REGULATIONS FOR EQUIPMENT, MATERIALS AND INSTALLATION.	
2. CONFORM TO CURRENT SMACNA STANDARDS, IMC AND WSEC FOR DUCT CONSTRUCTION, SEALING, MATERIAL, AND INSTALLATION.	
3. PROVIDE DUCT INSULATION ON ALL SUPPLY DUCTWORK & EXHAUST DUCTWORK IN ATTIC UNLESS SPECIFICALLY INDICATED. INSULATION THICKNESS AND R-VALUE SHALL COMPLY WITH WSEC 2021R 402 AS A MINIMUM.	
4. PROVIDE RECORD DRAWINGS AND OPERATION & MAINTENANCE MANUALS. COMPLY WITH WSEC AS A MINIMUM.	

GENERAL PLUMBING & PIPING NOTES	
1. MAKE CHANGE OF DIRECTION AND CONNECTIONS TO BRANCH LINES IN SANITARY WASTE, VENT AND STORM DRAINAGE PIPING WITH APPROVED FITTINGS. COMPLY WITH UPC REQUIREMENTS.	
2. ALL SANITARY WASTE AND VENT BELOW GRADE SHALL BE A MINIMUM OF 2" DIAMETER.	
3. PROVIDE CLEANOUTS IN ALL SANITARY WASTE AND STORM DRAINAGE PIPING AT A MAXIMUM OF 100 SPACING, UNLESS SPECIFICALLY INDICATED OTHERWISE. PROVIDE WALL CLEANOUTS AT SINKS AND AT BASE OF RISERS. COMPLY WITH UPC REQUIREMENTS.	
4. FIELD VERIFY ALL EXISTING EQUIPMENT TO BE DEMOLISHED PRIOR TO BID.	

GENERAL HVAC NOTES	
1. ALL DIMENSIONS SHOWN FOR DUCTWORK ARE NET INSIDE DIMENSIONS.	
2. COORDINATE EQUIPMENT DIFFUSER, REGISTER AND GRILLE LOCATIONS WITH ARCHITECTURAL INTERIOR ELEVATION DRAWINGS FOR EXACT LOCATIONS.	
3. DRAWINGS DO NOT SHOW ALL OFFSETS OR TRANSITIONS IN DUCTWORK OR PIPING. COORDINATE WITH ALL TRADES, DETERMINE FINAL ROUTING, AND PROVIDE ALL OFFSETS AND TRANSITIONS REQUIRED TO INSTALL MECHANICAL SYSTEMS.	
4. PROVIDE 1" (OR THICKNESS SPECIFICALLY INDICATED) INTERNAL ACOUSTICAL DUCT LINING ON ALL AIR HANDLING UNIT RECTANGULAR SUPPLY AND RETURN DUCTWORK. PROVIDE EXTERNAL INSULATION ON ALL ROUND DUCTWORK AND OUTSIDE AIR DUCTWORK.	
5. FIELD VERIFY ALL EXISTING EQUIPMENT TO BE DEMOLISHED BEFORE BID.	

ABBREVIATIONS	
ABOVE FINISHED FLOOR	AFF
ACCESS DOOR, ACCESS PANEL	AD, (AP)
BACKDRAFT DAMPER	BDD
CAST IRON	CI
CEILING	CLG
CEILING DIFFUSER	CD
CONCRETE	CONC
DOOR GRILLE	DG
ELEVATION	EL
EXHAUST, EXHAUST AIR	EXH, EA
EXHAUST GRILLE	EG
EXHAUST REGISTER	ER
INVERT ELEVATION	IE
LOUVER	LVR
NEW	(N)
NOT IN CONTRACT	NIC
NORMALLY CLOSED	NC
NORMALLY OPEN	NO
NOT TO SCALE	NTS
ON CENTER	OC
OUTSIDE (OUTDOOR) AIR	OSA
POINT OF CONNECTION	POC
RELIEF, RELIEF AIR	RL, RLA
RELIEF GRILLE	RLG
RETURN, RETURN AIR	RET, RA
RETURN GRILLE	RG
RETURN REGISTER	RR
SIMILAR	SIM
SUPPLY, SUPPLY AIR	SUP, SA
SUPPLY GRILLE	SG
SUPPLY REGISTER	SR
THROUGH	THRU
THROUGH BEAM	TB
THROUGH JOIST	TJ
TOP OF FOOTING	TOF
TRANSFER GRILLE	TG
VENT THROUGH ROOF	VTR

MECH. SYMBOLS LEGEND	
BALL VALVE	BV
CAPPED PIPE	
CHECK VALVE	CV
CLEANOUT	CO
CLEANOUT THROUGH FLOOR	COTF
CLEANOUT THROUGH WALL	COTW
CLEANOUT TO GRADE	COTG
CONNECT TO EXISTING, POINT OF CONNECTION	POC
ELBOW, TURNED DOWN	
ELBOW, TURNED UP	
FLOOR DRAIN	FD
FUNNEL FLOOR DRAIN	FFD
GATE VALVE	GV
GLOBE VALVE	GLV
HOSE BIBB	HB
P-TRAP	
PLUMBING FIXTURE SYMBOLS	(A) OR (AAA)
PRESSURE GAUGE	
PRESSURE REDUCING VALVE	PRV
RELIEF VALVE	RV
TEE, OUTLET DOWN	
TEE, OUTLET UP	
THERMOMETER	
THERMOSTAT	
UNION	
WALL HYDRANT, NON-FREEZE WH	WH, NFWH
Y-STRAINER	

PLUMBING PIPING LEGEND	
DIRECTION OF FLOW	
DIRECTION OF PIPE GRADE (DOWN)	
DOMESTIC COLD WATER	CW
DOMESTIC HOT WATER	HW
DRAIN	D
SANITARY SEWER - EXTERIOR	S
SANITARY WASTE (ABOVE GRADE)	
SANITARY WASTE (BELOW GRADE)	
VENT	V
WATER MAIN - EXTERIOR	W

HVAC LEGEND	
DUCT SECTION, POSITIVE PRESSURE (SA)	
DUCT SECTION, NEGATIVE PRESSURE (RA/EA/RLA/OSA)	
SUPPLY AIR FLOW	
RETURN, RELIEF OR EXHAUST AIR FLOW	
FIRE/SMOKE DAMPER, FIRE DAMPER	F/SD, FD
FLEXIBLE DUCT CONNECTOR	
MANUAL DAMPER	MD
DAMPER MOTOR, ACTUATOR	
INTERNAL DUCT LINER	
DUCT SIZE (FIRST FIGURE IS SIDE SHOWN)	20x12
ROUND FLEXIBLE DUCTWORK	
ROUND DUCTWORK	10"
TRANSITION (IN ROUND OR FLAT OVAL DUCT)	
SUPPLY DIFFUSER	CD 10x10 TYPE 200 (3), XXX NK SIZE CFM (QTY.), RUNOUT SIZE
GRILLE OR REGISTER	RR 12x8 TYPE 200 (3), XXX SIZE CFM (QTY.), RUNOUT SIZE
EQUIPMENT DESIGNATION (STYLE 1)	AHU 1 EQUIP. TYPE EQUIP. NUMBER
EQUIPMENT DESIGNATION (STYLE 2)	EF 2 EQUIP. TYPE EQUIP. NUMBER

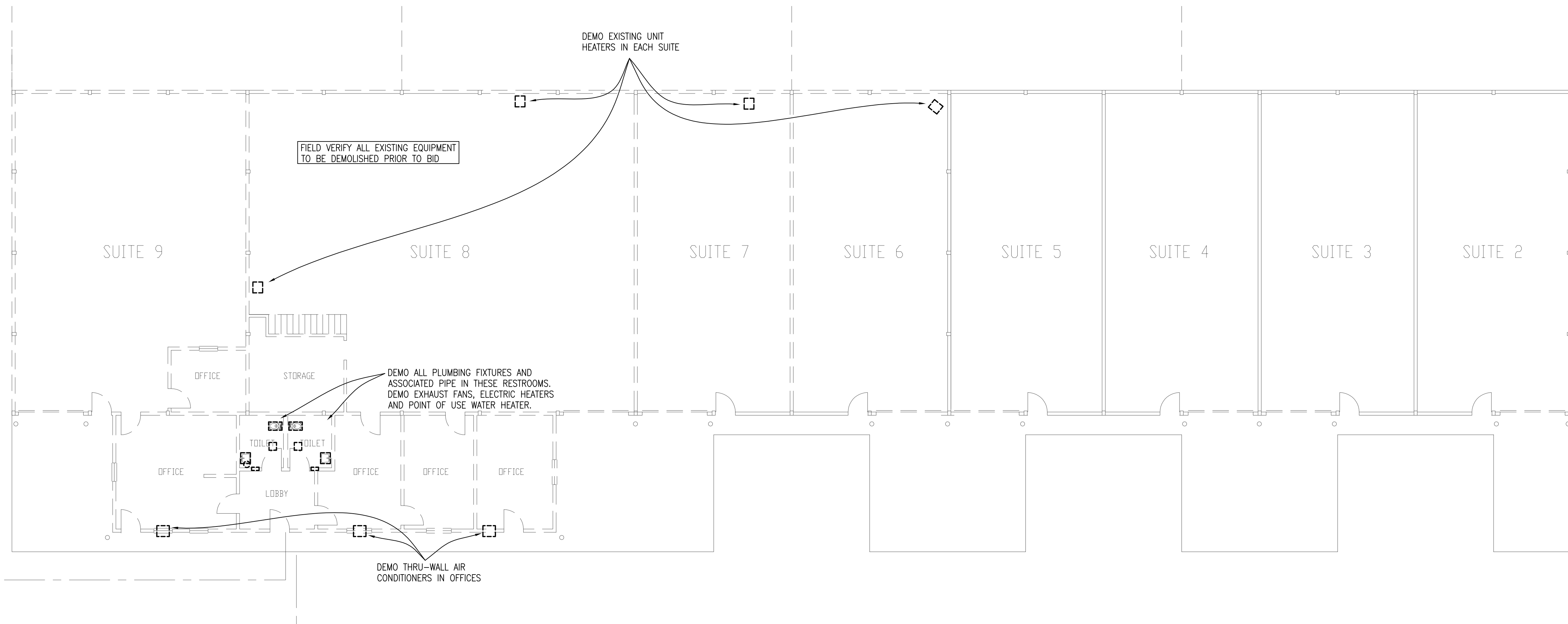

SITE PLAN
1" = 10'-0"

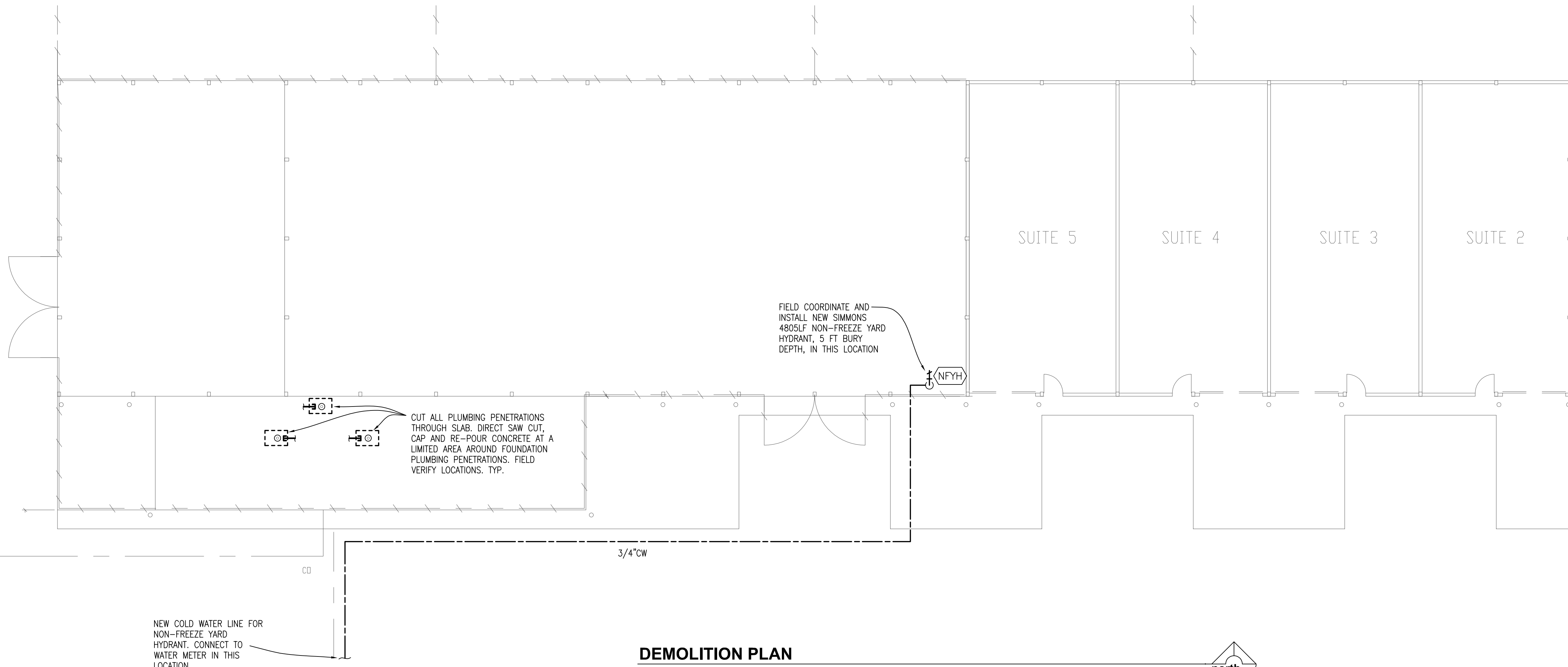

DEMOLITION PLAN
1" = 10'-0"



07/15/24

date: 07-15-24
project no. 2403
drawn: JME
checked: BGB
approved: BGB

DEMOLITION AND SITE PLANS - HVAC
PORT of KENNEWICK's EAST 3rd STORAGE BLDG SELECT DEMOLITION
1328 E. 3rd AVE, SUITES 6, 7, 8, and 9
KENNEWICK, WASHINGTON

GENERAL REFERENCE	
DESCRIPTION	SYMBOL
NOTE REFERENCE	Ⓝ Ⓞ Ⓟ
EQUIPMENT DESIGNATION	DESC
ROOM NUMBER	101
POWER DEVICES	
DESCRIPTION	SYMBOL
120V, 20A DUPLEX RECEPTACLE OUTLET MOUNTED @ +18" AFF	Ⓜ
"R" = RECEPTACLE FOR REFRIGERATOR MOUNTED @ +48" AFF "A" = RECEPTACLE MOUNTED +2" ABOVE COUNTERTOP IN BACKSPLASH, MAXIMUM 44" "UC" = RECEPTACLE FOR UNDERCOUNTER REFRIGERATOR "H" = RECEPTACLE MOUNTED HORIZONTALLY "TP" = TAMPER PROOF RECEPTACLE OUTLET DEVICE "OS" = HALF CONTROLLED RECEPTACLES BY OCCUPANCY SENSOR	
120V, 20A GFCI RECEPTACLE MOUNTED @ +18" AFF	Ⓜ
"WPU" = WEATHERPROOF WHILE-IN-USE RECEPTACLE COVER	
SPECIAL NEMA RECEPTACLE (TYPE NOTED ON DRAWINGS)	Ⓜ
PANELBOARD	Ⓜ
LIGHTING	
DESCRIPTION	SYMBOL
POLE LIGHT FIXTURE	Ⓜ
WALL PACK	Ⓜ
WALL SWITCH MOUNTED @ +44" AFF	Ⓜ
"3" THREE-WAY "4" FOUR-WAY "D" DIMMER	
PHOTOCELL	Ⓜ

- ### GENERAL ELECTRICAL NOTES
- ALL CONDUIT SHALL BE CONCEALED WHEREVER POSSIBLE. CONDUIT SHALL NOT BE EXPOSED IN FINISHED AREAS (EXCLUDES MECHANICAL ROOMS AND SIMILAR AREAS). IF UNABLE TO CONCEAL CONDUIT IN FINISHED AREA PROVIDE SURFACE RACEWAY SYSTEM PER SPECIFICATIONS.
 - OWNER RESERVES THE RIGHT TO RELOCATE ANY ELECTRICAL DEVICE UP TO A DISTANCE OF 6 FEET BEFORE INSTALLATION WITHOUT EXTRA CHARGE FROM ELECTRICAL CONTRACTOR.
 - ELECTRICAL DRAWINGS ARE DIAGRAMMATIC ONLY. EXACT LOCATION OF ALL SYSTEMS AND EQUIPMENT SHALL BE FIELD VERIFIED AND COORDINATED WITH OTHER TRADES PRIOR TO ANY INSTALLATION. WHERE EXACT LOCATIONS ARE NECESSARY, THEY ARE DIMENSIONED ON THESE DRAWINGS. WHERE THERE IS A QUESTION OF ADEQUATE CLEARANCE OR COORDINATION BETWEEN TRADES, THIS CONTRACTOR SHALL PREPARE SHOP DRAWINGS FOR ENGINEER'S REVIEW. ON ALL SPECIAL SYSTEMS REQUIRING DRAWINGS BY LICENSED INSTALLATION CONTRACTORS, SUCH AS FIRE PROTECTION, SUCH DRAWINGS SHALL BE SUBMITTED WITHIN 30 DAYS AFTER AWARD OF CONTRACT.
 - ALL CONDUCTORS SHALL BE COPPER UNLESS OTHERWISE NOTED.
 - REFER TO ARCHITECTURAL PLANS AND SPECIFICATIONS FOR PHASING OF WORK.
 - NO ATTEMPT HAS BEEN MADE TO SHOW OR OTHERWISE INDICATE FIRE RATED ASSEMBLIES (WALLS, FLOORS, CEILINGS, ETC); REFER TO ARCHITECTURAL PLANS. PROVIDE APPROPRIATELY RATED MATERIALS AND OR INSTALLATION PRACTICES TO MAINTAIN THE INTEGRITY OF RATED ASSEMBLIES. LABEL ANY AND ALL RATED ASSEMBLY PENETRATIONS PER SPECIFICATIONS.
 - CONTRACTOR TO PROVIDE PHOTOCELL CONTROLS FOR EXTERIOR LIGHTS, LIGHTS SHALL AUTOMATICALLY TURN OFF WHEN A SUFFICIENT AMOUNT OF AMBIENT LIGHTING IS PRESENT. PHOTOCELL TO BE AIMED AWAY FROM DIRECT SOURCES OF LIGHT. CONTRACTOR TO PROVIDE POLE LIGHT CONTROLS TO DIM LIGHTS BY 30% FROM MIDNIGHT TO 6AM. ALL CONDUCTORS FOR BUILDING AND POLE LIGHTING SHALL BE #10 AWG CU.

FIXTURE SCHEDULE

SYM	MANUFACTURER		FIX WATTS	LAMP TYPE	MOUNTING	REMARKS
	NAME	CAT. NO.				
S1	LITHONIA LIGHTING	RSX1 LED P3 40K R3 MVOLT SPA HS DDBXD	109W	LED 14023 LUMENS	POLE LIGHT	MOUNTED ON 30' SSS POLE (S1P) WITH 2.5' BASE
S1P	LITHONIA LIGHTING	SSSDB 30 6G DWHXD			POLE	30' WHITE POLE
S2	LITHONIA LIGHTING	DSXW1 LED 20C 1000 40K T4M MVOLT DDBXD	74W	LED 7420 LUMENS	WALL PACK	MOUNT AT 12' ABOVE FINSH GRADE.

PANELBOARD SCHEDULE

MAIN BREAKER: 2P-200A
MOUNTING: SURFACE
BRACING: 10 KAIC

PANEL: ST 5 PNL (EXST)
120/240V, 1P, 3W
200 AMP

TOTAL CALCULATED LOAD: 26.42 KVA
PANEL LOCATION: BAY 5
PANEL FED FROM: XFMR

NO	DESCRIPTION	CIRCUIT	OCP	TYPE	LOAD		PH	LOAD		TYPE	OCP	DESCRIPTION	NO
					(VA)	(A)		(VA)	(A)				
3	REC	1P-20A	R		540	4.5	A	8.3	1000	R	1P-20A	REC/LTS	2
4	REC	1P-20A	R		540	4.5	B	8.3	1000	R	1P-20A	REC/LTS	4
5	HEATER	2P-30A	H		2400	20.0	A	4.5	540	R	1P-20A	REC/LTS	6
6	HEATER	2P-30A	H		2400	20.0	B	20.0	2400	H	2P-30A	HEATER	8
7	WELDER	2P-50A	N		4200	35.0	A	20.0	2400	H	2P-30A	FAN	10
11	SPACE							20.0	2400	H	2P-30A	FAN	12
13	SPACE												14
15	SPACE												16
17	SPACE												18
19	SPACE												20

LOAD: CONNECTED CALCULATED
 (Continuous) x 1.25 = VA
 (Rec (1st 10 kw): 3620 x 1.00 = 3620 VA
 (Rec (remainder): x 0.50 = VA
 (Non-continuous): 8400 x 1.00 = 8400 VA
 (Heating): 14400 x 1.00 = 14400 VA
 (Air conditioning): x 1.00 = VA
 (Largest motor) x 1.25 = VA
 TOTAL LOAD: 26420 26420 VA
 110 AMPS

PANELBOARD SCHEDULE

MAIN BREAKER: 2P-200A
MOUNTING: SURFACE
BRACING: 10 KAIC

PANEL: ST 5 PNL (NEW)
120/240V, 1P, 3W
200 AMP

TOTAL CALCULATED LOAD: 27.70 KVA
PANEL LOCATION: BAY 5
PANEL FED FROM: XFMR

NO	DESCRIPTION	CIRCUIT	OCP	TYPE	LOAD		PH	LOAD		TYPE	OCP	DESCRIPTION	NO
					(VA)	(A)		(VA)	(A)				
3	REC	1P-20A	R		540	4.5	A	8.3	1000	R	1P-20A	REC/LTS	2
4	REC	1P-20A	R		540	4.5	B	8.3	1000	R	1P-20A	REC/LTS	4
5	HEATER	2P-30A	H		2400	20.0	A	4.5	540	R	1P-20A	REC/LTS	6
6	HEATER	2P-30A	H		2400	20.0	B	20.0	2400	H	2P-30A	HEATER	8
7	WELDER	2P-50A	N		4200	35.0	A	20.0	2400	H	2P-30A	FAN	10
11	NEW EXTERIOR LTS (S1 & S2)	2P-20A	C		368	3.1	A	20.0	2400	H	1P-20A	NEW EXTERIOR REC	12
13	SPACE												14
15	SPACE												16
17	SPACE												18
19	SPACE												20

LOAD: CONNECTED CALCULATED
 (Continuous) 736 x 1.25 = 920 VA
 (Rec (1st 10 kw): 3980 x 1.00 = 3980 VA
 (Rec (remainder): x 0.50 = VA
 (Non-continuous): 8400 x 1.00 = 8400 VA
 (Heating): 14400 x 1.00 = 14400 VA
 (Air conditioning): x 1.00 = VA
 (Largest motor) x 1.25 = VA
 TOTAL LOAD: 27516 27700 VA
 115 AMPS

NOTES:
BOLD TEXT INDICATES NEW CIRCUITS

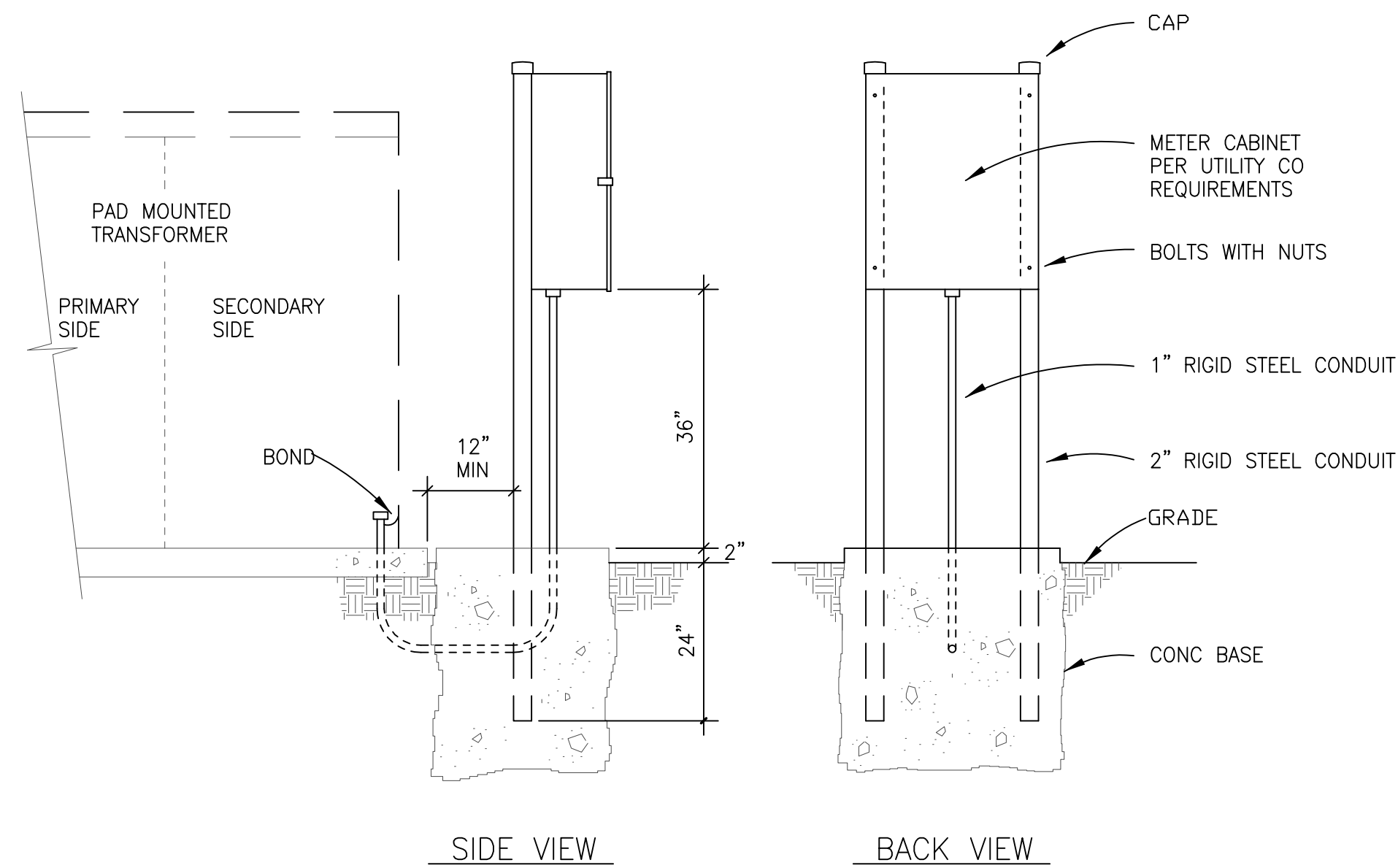

1 METER BASE DETAIL
NOT TO SCALE

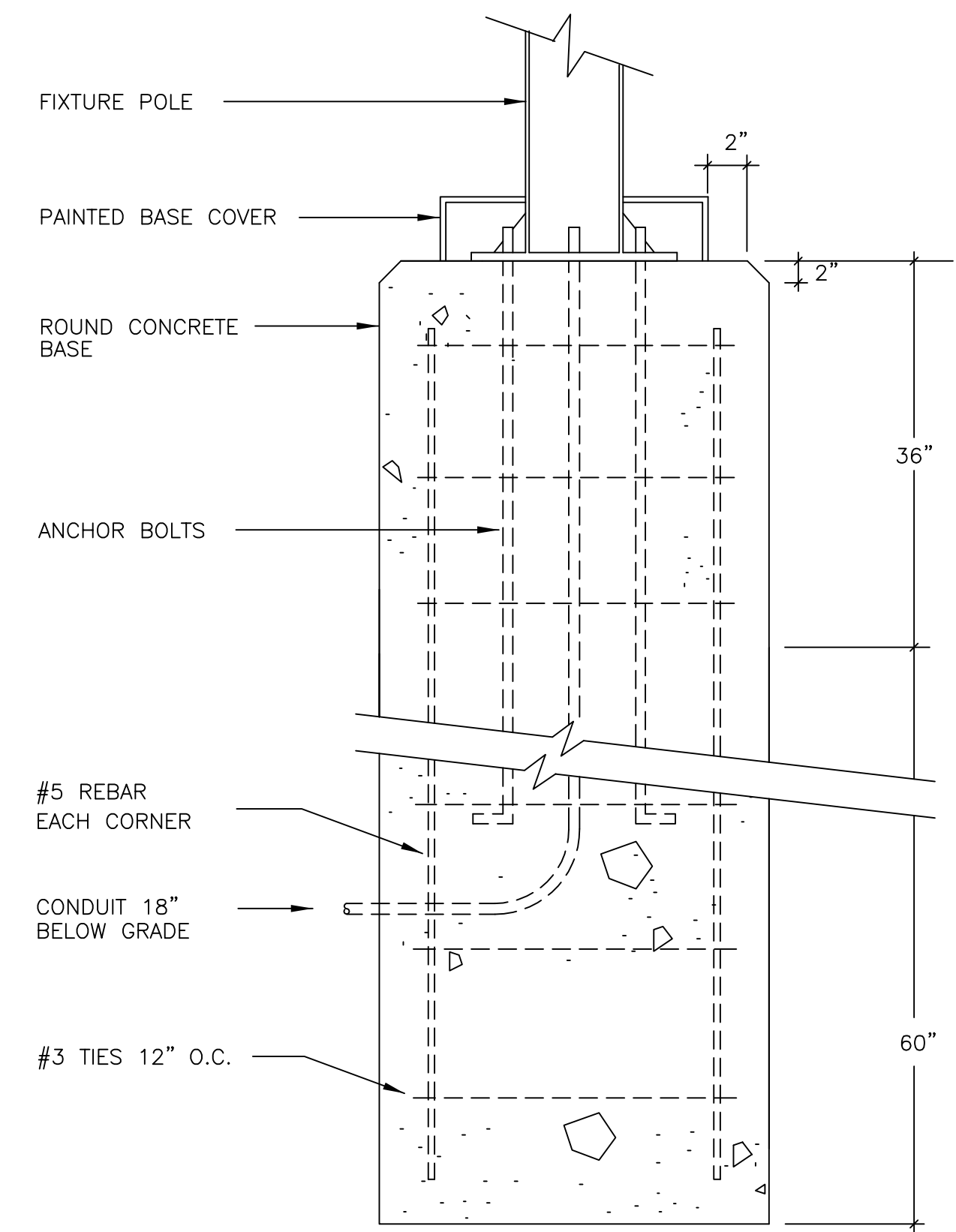

2 LIGHT POLE BASE DETAIL
NOT TO SCALE

ckjt architects, pllc
128 161st way
kennewick, wa 98336
360-865-5444



07/15/24
date: 07-15-24
project no. 2403
drawn: HMR
checked: JDW
approved: JDW

LEGENDS AND SCHEDULES
PORT of KENNEWICK's EAST 3rd STORAGE BLDG SELECT DEMOLITION
KENNEWICK, WASHINGTON
1329 E. 3rd AVE, SUITES 6, 7, 8, and 9

sht. E001
of sheets

GENERAL DEMO NOTES

- EXISTING PLANS ARE SHOWN FOR REFERENCE ONLY. NO ATTEMPT HAS BEEN MADE TO SHOW ALL EXISTING ELECTRICAL DEVICES, FIXTURES, CONDUIT RACEWAYS, BOXES, AND OTHER RELATED EQUIPMENT TO BE REMOVED. THE CONTRACTOR SHALL EXAMINE PREMISES AND BECOME FAMILIAR WITH EXISTING CONDITIONS TO DETERMINE EXTENT OF DEMOLITION WORK.
- PROVIDE ALL DEMOLITION WORK CALLED FOR OR REQUIRED BY THE PROJECT. REMOVE ALL EXISTING EQUIPMENT AND MATERIALS NOT REUSED UNLESS SPECIFIED OTHERWISE BY OWNER'S REPRESENTATIVE.
- OWNER SHALL HAVE FIRST RIGHTS TO ALL ELECTRICAL EQUIPMENT AND MATERIALS REMOVED. EQUIPMENT AND MATERIALS REMOVED AND NOT HANDED OVER TO THE OWNER SHALL BECOME PROPERTY OF THE CONTRACTOR UNLESS OTHERWISE NOTED AND SHALL BE IMMEDIATELY REMOVED OFF SITE.
- RECEPTACLES INDICATED TO BE REMOVED SHALL HAVE RECEPTACLES, CONDUIT AND BOXES REMOVED. REMOVE WIRING BACK TO PANEL.
- COORDINATE ELECTRICAL DEMOLITION WITH OTHER TRADES PRIOR TO STARTING WORK.
- REFER TO ARCHITECTURAL DRAWINGS FOR EXTENT OF DEMOLITION WORK.
- INDICATED PANELS, FEEDERS BACK TO SERVICE, AND METERS SHALL BE DEMOED.
- ALL ABANDONED CONDUIT TO BE CUT FLUSH WITH CONCRETE. PLUGGED AND GROUTED SOLID, FLUSH WITH THE CONCRETE.

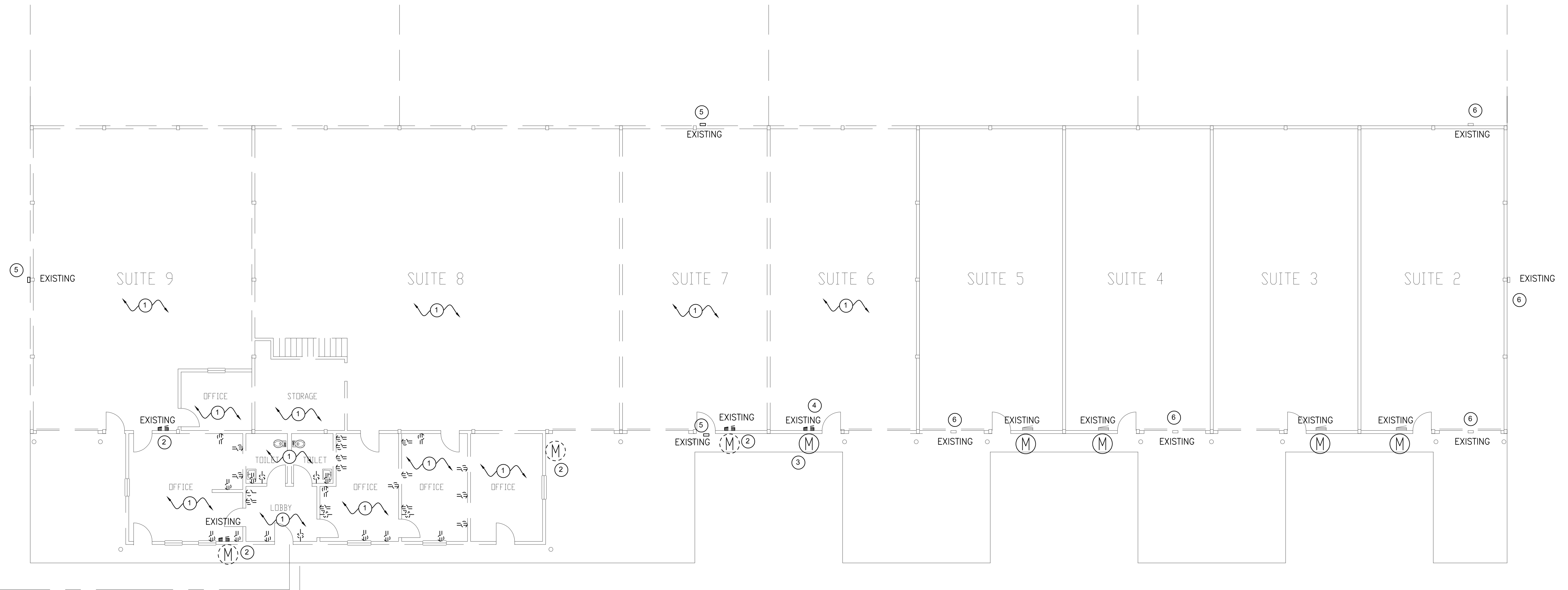

(E)4" SEWER LINE

KEYED NOTES

- DEMO ALL ELECTRICAL COMPONENTS IN UNIT, INCLUDING BUT NOT LIMITED TO PANELS, RECEPTACLES, DATA OUTLETS, SWITCHES, LIGHT FIXTURES, HVAC, CONDUIT, ETC.
- DEMO METER AND/OR PANEL.
- METER TO REMAIN FOR FUTURE USE. PROTECT AND PRESERVE FEEDERS, CONDUIT AND METER DURING DEMOLITION. PROVIDE UNISTRUT SUPPORT PER UTILITY COMPANY REQUIREMENTS FOR EXISTING METER. UNISTRUT SHALL BE ANCHORED WITH THROUGH EXISTING CONCRETE STRUCTURE.
- SUITE 6 PANEL SHALL BE DEMOED BACK TO METER.
- DEMO LIGHT FIXTURE, WIRING, AND CONDUIT BACK TO PANEL.
- LIGHT FIXTURE TO REMAIN.
- MOUNT PHOTOCELL AIMED AWAY FROM DIRECT SOURCES OF LIGHT. CONTRACTOR TO VERIFY LOCATION.
- POLE FOR S1 FIXTURE CALLED OUT AS S1P. 30' WHITE POLE. SEE FIXTURE SCHEDULE FOR DETAILS.

GENERAL NOTES

- PRESERVE THE METER FROM SUITE 6 FOR FUTURE USE.
- NEW EXTERIOR LIGHTS AND RECEPTACLES SHALL BE FED FROM SUITE 5 PANEL.
- PROVIDE #10 AWG CONDUCTORS AND A 2P-20A CIRCUIT BREAKER FOR EXTERIOR LIGHTING.
- PROVIDE WEATHERPROOF NEMA 3R RECEPTACLE COVERS FOR NEW RECEPTACLES.
- PHOTOCELL SHALL HAVE A BYPASS TO TEST THE SYSTEM.

DEMOLITION PLAN

1" = 10'-0"

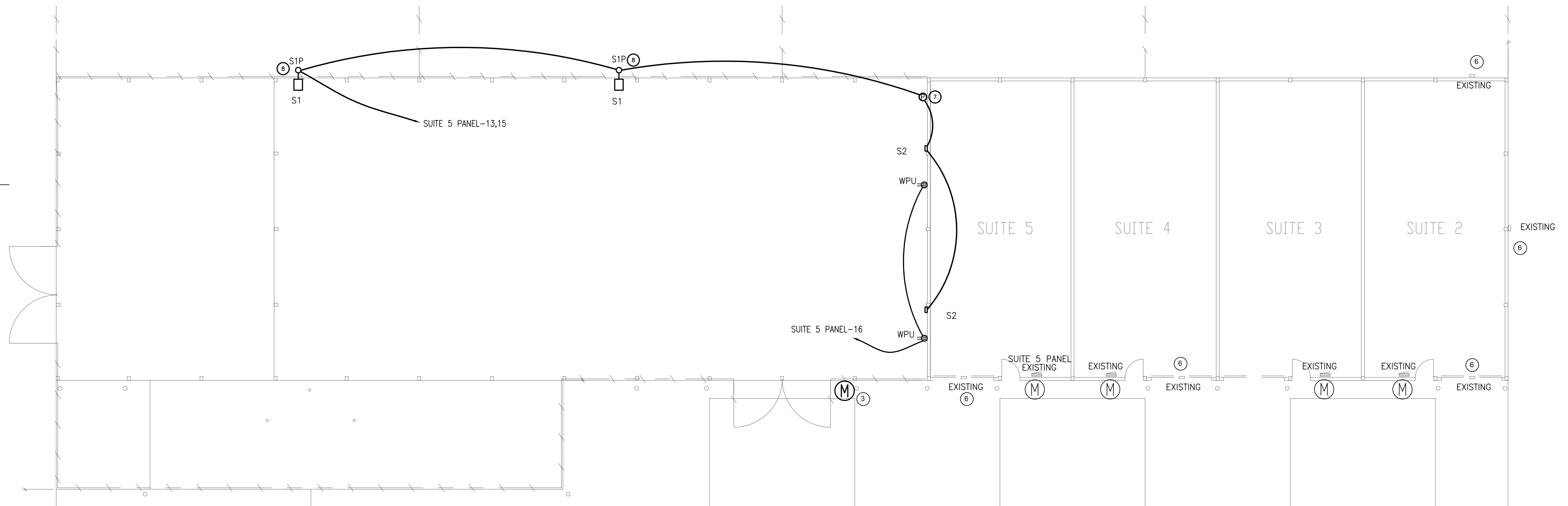
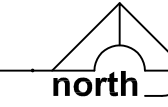

(E)4" SEWER LINE

ELECTRICAL PLAN

1" = 10'-0"



07/15/24

date: 07-15-24
 project no. 2403
 drawn: HMR
 checked: JDW
 approved: JDW

ELECTRICAL EXISTING SITE PLAN and DEMOLITION PLAN
PORT of KENNEWICK's EAST 3rd STORAGE BLDG SELECT DEMOLITION
 1328 E. 3rd AVE, SUITES 6, 7, 8, and 9
 KENNEWICK, WASHINGTON

sht. E101

of sheets