

Port of Kennewick will provides telephonic, video access, and in-person participation options to the public.

To participate by telephone, please call in at: 1-877-309-2073, Access Code: 441-679-877

Or, join on-line at the following link: <https://meet.goto.com/441679877>

AGENDA

Port of Kennewick

Regular Commission Business Meeting

*Port of Kennewick Commission Chambers and via GoToMeeting
350 Clover Island Drive, Suite 200, Kennewick Washington*

April 14, 2026

2:00 p.m.

- I. **CALL TO ORDER**
- II. **ANNOUNCEMENTS AND ROLL CALL**
- III. **PLEDGE OF ALLEGIANCE**
- IV. **PUBLIC COMMENT** (*Please state your name and address for the public record*)
- V. **CONSENT AGENDA**
 - A. Approval of Direct Deposit and ePayments April 1, 2026
 - B. Approval of Warrant Register Dated April 14, 2026
 - C. Approval of Regular Commission Meeting Minutes March 24, 2026
- VI. **PRESENTATIONS**
 - A. Mid-Columbia Children's Museum, Chelsea Blair (**TIM**)
 - B. New Urbanism Immersion Tour (**RAUL**)
 - C. Employee Introductions - Administrative (**TIM/BRIDGETTE**)
- VII. **REPORTS, COMMENTS AND DISCUSSION ITEMS**
 - A. Vista Field
 - 1. Development Agreement (**TIM**)
 - B. Kennewick Waterfront
 - 1. Clover Island Artwork (**MICHAEL**)
 - C. Public Disclosure Commission (**BRIDGETTE**)
 - D. CEO Report (if needed) (**TIM**)
 - E. Commission Meetings (formal and informal meetings with groups or individuals)
 - F. Non-Scheduled Items
LISA/BRIDGETTE/ROCHELLE/NICK/LARRY/AMBER/MICHAEL/DAVID/CAROLYN/TIM/RAUL/SKIP/KEN

VIII. PUBLIC COMMENT *(Please state your name and address for the public record)*

IX. EXECUTIVE SESSION, Potential Litigation, pursuant to RCW 42.30.110 (1)(i)(iii)

Two matters related to the legal and financial risk of a proposed action that the agency has identified when public discussion of the legal risks is likely to result in an adverse legal or financial consequence to the agency.

X. ADJOURNMENT

PLEASE SILENCE ALL NOISE MAKING DEVICES



PORT OF KENNEWICK REGULAR COMMISSION MEETING

DRAFT

MARCH 24, 2026 MINUTES

Commission Meeting recordings, with agenda items linked to corresponding audio, can be found on the Port's website at: <https://www.portofkennewick.org/commission-meetings-audio/>

Commission Vice President Skip Novakovich called the Regular Commission Meeting to order at 2:00 p.m.

ANNOUNCEMENTS AND ROLL CALL

The following were present:

Board Members: Kenneth Hohenberg, President (Excused)
Skip Novakovich, Vice President
Raul Contreras Gonzalez, Secretary

MOTION: *Commissioner Contreras Gonzalez moved to excuse Commissioner Hohenberg's absence from the March 24, 2026 Commission Meeting; Commissioner Novakovich seconded. With no further discussion, motion carried unanimously. All in favor 2:0.*

Staff Members: Tim Arntzen, Chief Executive Officer
Tana Bader Inglima, Deputy Chief Executive Officer
Nick Kooiker, CFO/Deputy Chief Executive Officer
Amber Hanchette, Director of Real Estate
Michael Boehnke, Director of Operations
Rochelle Olson, Director of Governmental Affairs
Bridgette Scott, Executive Assistant (via telephone)
Lisa Schumacher, Special Projects Coordinator
David Phongsa, Marketing/Capital Projects Coordinator
Carolyn Lake, Port Counsel (via telephone)

PLEDGE OF ALLEGIANCE

Dan Richey, West Richland Council Member, led the Pledge of Allegiance.

PUBLIC COMMENT

Adam Fyall, Richland, read a letter from the Benton County Commission (*Exhibit A*).

Benton County does a lot of work with many different partners in this community and beyond. One of our best working relationships is with the Port of Kennewick. Thanks to your Commission and staff of efficiency, responsiveness, and overall good practices that makes the Port easy to work with and effective. A big contributor to this reputation and reality has been Tana Bader Inglima. Tana has been our main point of contact at the Port for nearly two decades, and this has made it easy and enjoyable for us to do work with the Port. We are excited for Tana as she embarks on her life's next journey as we look forward to our continued work on many great projects with the Port of Kennewick team. Thank you for being a consistently great partner.

PORT OF KENNEWICK REGULAR COMMISSION MEETING

MARCH 24, 2026 MINUTES

DRAFT

Tana, we are very happy for you to reach this milestone, and we wish you all the best in your retirement. Congratulations, safe travels, and good health to you. You've earned it!

*Sincerely
Benton County Commissioners
Michael Alvarez, Chairman
Will McKay, Chairman Pro-Tem
Jerome Delvin, Commissioner*

Mr. Fyall has worked with Ms. Bader Inglima for 25 years and expressed his sentiments as well as the Commission, who wanted to send these good notes to Ms. Bader Inglima. With retirement there are often a few tears and sadness, but there is no sadness, we are all excited for her next journey and we are all trying to get to that same milestone. Mr. Fyall is excited to work with Ms. Olson and everyone else on the Port team, going forward. Mr. Fyall stated the Commission said it well and he echoes their comments; the Port of Kennewick is one of our best partners and we are lucky in this community to have a lot of great partners. Mr. Fyall stated good luck to Ms. Bader Inglima and we will stay in touch, even after you leave.

No further comments were made.

CONSENT AGENDA

- A. Approval of Direct Deposit and E-Payments Dated March 17, 2026**
Direct Deposit and E-Payments totaling \$146,334.87
- B. Approval of Warrant Register Dated March 24, 2026**
Expense Fund Voucher Number 107778 through 107808 for a grand total of \$233,589.03
- C. Approval of Regular Commission Meeting Minutes March 10, 2026**

MOTION: Commissioner Contreras Gonzalez moved to approve the Consent Agenda; Commissioner Novakovich seconded. With no further discussion, motion carried unanimously. All in favor 2:0.

PRESENTATIONS

A. Employee Introductions – Governmental Relations

Mr. Arntzen introduced Ms. Bader Inglima and Ms. Olson, the Port's Governmental Relations team.

Ms. Bader Inglima gave a brief presentation on the Governmental Relations team (*Exhibit B*).

Ms. Olson stated Ms. Bader Inglima and the team have done incredible work on important, meaningful things for our community and she looks forward to continuing that. Ms. Olson thanked Ms. Bader Inglima for all the time she has given her to ensure Ms. Olson is successful in her new role.

B. Clover Island Artwork Update

Mr. Boehnke updated the Commission on the repair of public art on Clover Island (*Exhibit C*).

PORT OF KENNEWICK REGULAR COMMISSION MEETING

MARCH 24, 2026 MINUTES

DRAFT

C. Commissioners Rules of Policy and Procedure

Mr. Arntzen briefed the Commission on the Commission Rules of Policy and Procedure (*Exhibit D*).

D. Community Ambassador Policy

Mr. Arntzen outlined the Community Ambassador Policy (*Exhibit E*).

NEW BUSINESS

A. Vista Field

1. Development Agreement

Mr. Peterson stated the current Vista Field Development Agreement was signed in December 2017, which outlined the contract between the City of Kennewick and the Port. The Agreement established the regulatory, timing and financial commitments of all parties. Because the Agreement expires in 2027, the Port believed it was time for a 10-year extension and has been working with City staff on the revised document. Mr. Peterson presented Resolution 2026-06, the Development Agreement for Vista Field, for Commission consideration.

MOTION: Commissioner Contreras Gonzalez moved for the approval of Resolution 2026-06 approving the Vista Field Development Agreement; Commissioner Novakovich seconded.

PUBLIC COMMENT

No comments were made.

Commission Discussion:

Commissioner Contreras Gonzalez agrees with Mr. Peterson that the timing is right for a new Development Agreement and with the recent opening of Blueberry Bridal, and Kuki Izakaya soon to follow, the Port has the traction. And by having this document in place, Commissioner Contreras Gonzalez believes the Port will be getting a lot of attention from potential builders.

Commissioner Novakovich asked for clarification, is it a 10-year extension for the end of the current term or today.

Mr. Peterson stated municipal code allows for a duration of ten years for a Development Agreement. The Port is requesting a new Development Agreement, and as soon as it is approved, it will begin the 10-year period. City staff is reading it as the Agreement would expire in 2037; so the attorneys will have the final determination. Mr. Peterson would like to revisit the document in five to eight years, based on the increased development in Vista Field.

With no further discussion, motion carried unanimously. All in favor 3:0.

2. Interlocal Agreement with the City of Kennewick (Joint Use Parking Lot E)

Mr. Arntzen presented Resolution 2026-07, approving the Interlocal Agreement (ILA) and

PORT OF KENNEWICK REGULAR COMMISSION MEETING

MARCH 24, 2026 MINUTES

DRAFT

Exhibits A and B with the City of Kennewick to construct a joint parking lot (460 spaces) for Vista Field and the Entertainment District, near Grandridge Boulevard. By combining resources, the Port and City can construct the needed infrastructure in a cost-effective manner.

Mr. Peterson stated the City Council will be considering the ILA at a future meeting.

MOTION: *Commissioner Contreras Gonzalez moved for the approval of Resolution 2026-07 authorizing Interlocal Agreement with the City of Kennewick for the Joint Use Parking lot; and that all action by port officers and employees in furtherance hereof is ratified and approved; and further, the Port Chief Executive Officer is authorized to take all action necessary in furtherance hereof; Commissioner Novakovich seconded.*

PUBLIC COMMENT

No comments were made.

With no further discussion, motion carried unanimously. All in favor 3:0.

REPORTS, COMMENTS AND DISCUSSION ITEMS

A. Public Disclosure Commission F-1 Forms

Ms. Scott stated the Public Disclosure Commission F1 report is due by April 15, 2026. In addition, the Port Commission Rules of Policy and Procedures states "...on an annual basis and in a public forum, each Commissioner shall acknowledge the obligation to disclose any conflicts of interest..." This can be done either verbally during a Commission meeting or submit a letter or email to Ms. Scott.

Commissioner Novakovich inquired if he is in compliance.

Ms. Scott stated that Commissioner Novakovich is in compliance.

B. CEO Report

Mr. Arntzen had a few words regarding Ms. Bader Inglima's retirement and stated she has been such a blessing to the Port. Ms. Bader Inglima has been with the Port for 18 years and has done so many great things for Mr. Arntzen, Port staff, Commissioners, and this community and stated it has been a great opportunity to work with her. Over the past 18 years, Ms. Bader Inglima has written nominations for 16 awards and honors, led a marketing and public outreach campaign for closing of the Vista Field airport, and the Master Planning effort for the redevelopment, coordinated the largest ground opening event at Vista Field and most recently worked on the PFAS issue. Ms. Bader Inglima has written 28 grant applications and secured \$14,700,000 in funding for Port projects and worked on restoring Clover Island over the past fifteen years. Mr. Arntzen stated Ms. Bader Inglima is a friend, and one of the most well-known faces in our community and it amazing how she has been honorable, and thoughtful in how she has conducted her personal and professional life. Ms. Bader Inglima also established a very good working relationship with the

PORT OF KENNEWICK REGULAR COMMISSION MEETING

MARCH 24, 2026 MINUTES

DRAFT

CTUIR and Mr. Arntzen cannot express enough how much she has touched every one of us at the Port and the community, and thanked her for her service.

Ms. Bader Inglima thanked Mr. Arntzen for his comments and kind words and thanked the Commission for their investment in the many projects she was able to be involved with and stated it has been her honor to be a public servant through the Port of Kennewick these many years. She will miss everyone and stated it has been an honor and privilege and is blessed to be a part of the team.

Commissioner Novakovich added that Ms. Bader Inglima has been a blessing to the Port.

Commissioner Contreras Gonzalez thanked Ms. Bader Inglima for keeping him informed for the past several years.

C. Commissioner Meetings (formal and informal meetings with groups or individuals)

Commissioners reported on their respective committee meetings.

D. Non-Scheduled Items

Mr. Kooiker offered his congratulations to Ms. Bader Inglima on her retirement.

Mr. Peterson stated Ms. Bader Inglima has a great skill set and character and the way she conducts herself helped everyone want to be better.

Ms. Hanchette stated she began working with Ms. Bader Inglima at the Visitor and Convention Bureau years ago and has enjoyed all their time together. Ms. Hanchette will miss Ms. Bader Inglima and is very happy for Ms. Olson in her new position.

Mr. Boehnke stated it has been wonderful working with Ms. Bader Inglima, and he knows that she will stay in touch.

Mr. Boehnke reported that the Vista Field water features will be up and running by next week.

Ms. Lake thanked Ms. Bader Inglima for all her work and stated she has been a wonderful face for the Port.

Mr. Arntzen and Commissioner Novakovich had dinner last night with several CTUIR members, to discuss potential projects. The CTUIR is looking for assistance in gaining access to some of our local institutions for a presentation on Native American history. Mr. Arntzen expressed that it is always good to maintain our relationships with our partners.

PORT OF KENNEWICK REGULAR COMMISSION MEETING

MARCH 24, 2026 MINUTES

DRAFT

Commissioner Novakovich read an invitation into the record:

Donors, Dignitaries, Officers, Trustees, Directors, and Colleagues,

The moment has arrived for the Confederated Tribes of the Umatilla Indian Reservation (CTUIR) to officially announce that Fred L. Mitchell of Walla Walla, WA, owner of the finest collection of twentieth-century Columbia River Plateau beadwork in existence, is transferring ownership and care of his vast collection to the CTUIR dba Tamástslikt Cultural Institute. We invite all who have helped achieve this milestone to join this celebration.

In the 1990's, the Tamástslikt project commenced with no collection to display in the interpretive depiction of the Cayuse, Umatilla, and Walla Walla Tribes' cultures and histories. While the Institute collection has grown in the three decades since, the Fred L. Mitchell & Family Collection represents an extraordinary change in the material culture belongings that will become available to display at Tamástslikt. Notably, Tamástslikt plans to loan objects to museums in the entire Columbia River Plateau region so that many publics can benefit from the decades of Mr. Mitchell's collecting.

Mr. Mitchell's collection represents three-quarters of a century gathering from up and down the Columbia mainstem as well as the Snake and Clearwater Rivers among other tributaries. His collection includes hundreds of exquisitely beaded bags and pouches, cradleboards, dresses, vests, gauntlets, horse-trappings, cornhusk bags, huckleberry baskets, more than 1,250 late-19th and early-20th century photographs, and roughly 15,000 lithic points and tools.

We truly appreciate everyone who has helped us and hope to see you on March 31st at 11 a.m. on March 31, Tuesday, in the Nixyáawii Governance Center, 46411 Timine Way, Pendleton, OR.

PUBLIC COMMENTS

No comments were made.

ADJOURNMENT

With no further business to bring before the Board; the meeting was adjourned at 3:25 p.m.

**PORT OF KENNEWICK
REGULAR COMMISSION MEETING**

MARCH 24, 2026 MINUTES

DRAFT

APPROVED:

**PORT of KENNEWICK
BOARD of COMMISSIONERS**

Kenneth Hohenberg, President

Skip Novakovich, Vice President

Raul Contreras Gonzalez, Secretary

PORT OF KENNEWICK

Resolution No. 2026-06

***A RESOLUTION OF THE BOARD OF COMMISSIONERS
OF THE PORT OF KENNEWICK APPROVING A DEVELOPMENT
AGREEMENT FOR THE REDEVELOPMENT OF
THE VISTA FIELD PROPERTY***

WHEREAS, the former Vista Field Airport property in the City of Kennewick provides an economic development opportunity for the Port of Kennewick and the City of Kennewick; and

WHEREAS, the Vista Field Redevelopment Master Plan contains significant deviations from current City of Kennewick regulations and practices; and

WHEREAS, providing certainty to the City, Port, citizens and development community will benefit all; and

WHEREAS, the City may authorize these deviations through the execution of a Development Agreement; and

WHEREAS, the City and Port executed the initial Vista Field Development Agreement in December 2017, which established 10-year period of design and development assurance to City, Port, land purchasers, builders and citizens; and

WHEREAS, the City and Port executed the initial Vista Field Development Agreement in December 2017, which established 10-year period of design and development assurance to City, Port, land purchasers, builders and citizens; and

WHEREAS, the Port has worked closely with the City to review the commitments made in 2017 Vista Field Development Agreement those “lessons learned” during the subsequent 8 years to refine the agreement to suit the needs and concerns of all parties; and

NOW THEREFORE, BE IT RESOLVED that the Port of Kennewick Board of Commissioners hereby approves the 2026 Vista Field Development Agreement (Exhibit 1).

ADOPTED by the Board of Commissioners of the Port of Kennewick this 24th day of March 2026.

***PORT of KENNEWICK BOARD
of COMMISSIONERS***

By:

Excused

Kenneth Hohenberg, *President*

By:

DocuSigned by:

Skip Novakovich

0E53A30E1C8E442...

Skip Novakovich, *Vice President*

By:

Signed by:

Raul Contreras Gonzalez

5D13B8E79C1A45F...

Raul Contreras Gonzalez, *Secretary*

AFTER RECORDING RETURN TO:

City of Kennewick
210 W. 6th Avenue
Kennewick WA 99336
Attn: City Clerk

CITY OF KENNEWICK AND PORT OF KENNEWICK

VISTA FIELD DEVELOPMENT AGREEMENT

Abbreviated Legal Description:

Parcel 1: REAL PROPERTY LOCATED IN SECTION 32, TOWNSHIP 9 NORTH, RANGE 29 EAST, WILLAMETTE MERIDIAN;

Parcel 2: LOT 2, SHORT PLAT NO. 1333, in VOL. 1 OF SHORT PLATS, PAGE 1333;

Parcel 3: LOT 3, SHORT PLAT 3336, in VOLUME 1 OF SHORT PLATS, PAGE 3336;

Parcel 4: LOT 2, SHORT PLAT 3336, in VOLUME 1 OF SHORT PLATS, PAGE 3336;

Parcel 5: A PORTION OF PARCEL 3 OF RECORD SURVEY NO. 1-521;

Parcel 6: TRACT B OF RECORD SURVEY No. 2339; AND

Parcel 7: A PORTION OF PARCEL 7 OF RECORD SURVEY 1-522;

RECORDS OF BENTON COUNTY WASHINGTON; ALL LOCATED WITHIN THE CITY OF KENNEWICK, BENTON COUNTY, WASHINGTON.

Tax Parcel Identification Numbers:

Benton County Assessor's Tax Parcels:

1-3299-100-0003-013

1-3299-101-1333-002

1-3299-101-3336-003

1-3299-101-3336-002

1-3299-100-0003-014

1-3299-300-0009-002

1-3299-300-0005-004

FULL LEGAL DESCRIPTION ATTACHED AT EXHIBIT A

TABLE OF CONTENTS

	<u>Page</u>
1. DEVELOPMENT AGREEMENT	1
2. VISTA FIELD PROPERTY.....	1
3. RECITALS AND FINDINGS.....	1
4. VISTA FIELD MASTER PLAN AND ZONING	1
4.1 Approval of Vista Field Master Plan and Map.....	1
4.2 Urban Mixed Use Zoning Ordinance	1
5. TRANSPORTATION	2
5.1 Vista Field Roadway Design Criteria Element	2
5.2 Transportation System Impacts and Mitigation.....	2
6. UTILITIES.....	3
6.1 Stormwater System Improvements	3
6.2 Sewer System Improvements	3
6.3 Water System Improvements	3
7. CITY OF KENNEWICK DESIGN STANDARDS AND PARK AND FIRE PROTECTION FACILITIES IMPACT FEES.....	3
8. VESTING.....	4
8.1 Effect of Development Agreement on Subsequent Development Regulations	4
8.2 Vested Rights	4
8.3 Exception to Vesting/Serious Threat to Public Health	5
9. AGREEMENT TERM AND EFFECTIVE DATE	5
10. MINOR PLAN MODIFICATIONS	5
11. GENERAL PROVISIONS.....	5
11.1 Default	5
11.2 Extension of Time for Performance	5
11.3 Governing Law, Remedies and Venue	6
11.4 Dispute Resolution	6
11.5 Construction.....	6
11.6 Complete Agreement and Conflicts	6
11.7 Waiver and Severability.....	7
11.8 Binding Effect	7
11.9 Cooperation	7
11.10 Transfer or Assignment	7

11.11 Effect of Development Agreement on City Rates and Fees..... 8
11.12 No Public Official Liability 8
11.13 Notices 8
11.14 Warranty of Authority 8

EXHIBITS TO THIS AGREEMENT

- Exhibit A: Vista Field Property Legal Description
- Exhibit B: Vista Field Property Parcel Map
- Exhibit C: Vista Field Master Plan 2017
- Exhibit D: Vista Field Master Plan - Layout
- Exhibit E: Vista Field Roadway Design Criteria Elements
- Exhibit F: Vista Field Redevelopment Project Transportation System Impact Evaluation (Part)
- Exhibit G: Fire Lane Access Intersection Triangle Example

**City of Kennewick and Port of Kennewick
VISTA FIELD DEVELOPMENT AGREEMENT**

1. DEVELOPMENT AGREEMENT. THIS VISTA FIELD DEVELOPMENT AGREEMENT (“Agreement”) is entered between the City of Kennewick, Washington, a Washington municipal corporation (“City”) and the Port of Kennewick, a Washington municipal corporation (“Port”). The City and Port are each a “Party,” and collectively the “Parties” to this Agreement. The Parties agree as follows.

2. VISTA FIELD PROPERTY. This Agreement applies to the Vista Field Redevelopment Area (the, “Property”). The Property is described in attached Exhibit A. A parcel map of the Property is attached as Exhibit B. All Exhibits to this Agreement are attached hereto and incorporated herein by this reference.

3. RECITALS AND FINDINGS.

3.1 The Port has approved a Master Plan to guide the redevelopment of Vista Field.

3.2 The City and the community has participated in development of Vista Field Master Plan including key elements related to land use planning, development standards, infrastructure and other improvements.

3.3 The Port and the City are authorized by law, including Chapter 36.70B RCW, to enter into a development agreement setting forth the development standards and other provisions to apply to development of the Property, all as set forth in this Agreement.

3.4 The Port enters this Agreement to provide certainty for the development community in the planning and redevelopment of the Property, including the funding and consideration received for meeting the development standards incident to the Vista Field Master Plan which are in excess of those necessary to facilitate Vista Field redevelopment alone.

3.5 The City and Port determine that this Agreement is appropriate to establish planning principles, development standards, and procedures in order to eliminate uncertainty in the redevelopment of Vista Field and to guide the orderly development of the Property, including the funding of improvements identified herein.

3.6 The City and Port each conducted public hearings in advance of approval of this Agreement as required by RCW 36.70B.200. And the City Council by ordinance and Port Commission by resolution each approved the Agreement and the associated Preliminary Plat.

4. VISTA FIELD MASTER PLAN AND ZONING.

4.1 **Approval of Vista Field Master Plan and Map.** The Vista Field Master Plan at Exhibit C and Vista Field Redevelopment Master Plan-Layout at Exhibit D are hereby adopted and approved and shall remain in effect and applicable to the Property during the Agreement Term.

4.2 **Urban Mixed Use Zoning Ordinance.** Kennewick Municipal Code 18.80, 18.12.010A.1, 18.12.010A.2, 18.12.010B.1, 18.12.010B.2, 18.12.030, 18.12.040, 18.12.250, 18.12.270, 18.12.280, 18.24.030, and 18.36.067 are incorporated by this reference and shall remain applicable to the Property during the Agreement Term.

5. TRANSPORTATION.

5.1 **Vista Field Roadway Design Criteria Element.** Exhibit E identifying the street plan and profile for roadways in Vista Field is hereby adopted and approved and shall remain applicable to the Property during the Agreement Term.

5.2 **Transportation System Impacts and Mitigation.** The Vista Field Redevelopment Project Transportation System Impact Evaluation (part) is attached as Exhibit F and incorporated herein by reference. The cost allocation table contained within Exhibit F outlining percentage impacts from Vista Field Development shall be applicable during the term of this agreement. Allocated percentage shall be based on actual construction costs at time of construction. Timing of improvements discussed herein shall be determined by those intersections which are close to exceeding the Level of Service (LOS) thresholds identified in Exhibit F. The following responsibilities and actions are deemed both necessary and appropriate to assure proper function of the transportation network within the Vista Field vicinity.

5.2.1 The City of Kennewick shall perform/collect bi-annual vehicle counts and other data at the locations identified in Exhibit F to determine intersection operation-levels of service to identify timing for transportation system improvements set out in Exhibit F for identified LOS.

5.2.2 The City may review and consider additional intersections within the TIF zone that includes the Vista Field Property as TIF eligible, that are not already identified in Exhibit F if consistent with standard engineering practices. However, TIF collected from development of the Vista Field Property shall be first applied to improvements identified in Exhibit F and then to subsequently identified TIF eligible projects within the Vista Field TIF zone.

5.2.3 The City will be responsible for the design and implementation of all offsite intersection improvements identified in Exhibit F. The City will notify the Port upon determination that an intersection is close to exceeding the LOS standards, and upon initiation of design work provide the Port with the Engineers' Cost Estimate prior to advertising the project for bid. The Parties acknowledge that assuming a given intersection listed in Exhibit F is on the City's TIF eligible project list for that zone, any TIF collected from the Vista Field Development will be utilized to offset the Port's proportionate share of the project costs as shown in the allocation table of Exhibit F. All TIF collected outside of the Vista Field Property but within that zone may be utilized to offset the City's proportionate share of the project costs. The remaining balance will be split between the Port and the City based upon the allocation table found in Exhibit F. The Port agrees to pay to the City a 3% construction management fee to manage each capital project. The Parties agree the 3% will be calculated against the successful bid for each project. Upon City acceptance of project at substantial completion and written notification by the City to the Port, the Port shall reimburse the City for the Port's percentage (identified in Exhibit F) of the total project costs plus the administrative fee within forty-five (45) days.

5.2.4 The Port shall plan, design and implement all onsite transportation system improvements that are the Port's sole responsibility as shown in Exhibit F ("100%" in column 14), and such other transportation improvement's as may be required for which the City does not have responsibility to participate in funding under this Agreement.

5.2.5 The Port will be responsible for the design and implementation for all four (4) major entrances to Vista Field noted in the Vista Field Master Plan, to wit: (1) the North East entrance at Kellogg Street and Quinault Avenue; (2) the South West entrance at Deschutes Avenue and Young

Street; (3) the Southern entrance at Deschutes Avenue; and (4) the Northern entrance at Grandridge Boulevard.

6. UTILITIES

6.1 **Stormwater System Improvements.** The storm water drainage systems shall be designed to locate all infiltration elements outside of roadway sections. Drywells and infiltration systems shall be located behind curb and gutter lines.

6.2 **Sewer System Improvements.** The City analyzed the existing City sewer system and determined the system within the vicinity of the Vista Field development is adequate to accommodate buildout of Vista Field as identified in the Master Plan.

6.3 **Water System Improvements.** The City analyzed the existing City water system and determined the system within the vicinity of the Vista Field development requires improvements to accommodate fire flows to support build out of Vista Field as identified in the Master Plan.

6.3.1 The Port agrees to design and install a 12-inch diameter waterline along the main East West road connecting the water systems in Young Street to Kellogg Street.

7. CITY OF KENNEWICK DESIGN STANDARDS AND PARK AND FIRE PROTECTION FACILITIES_ IMPACT FEES.

7.1 **Street and Access Design.** The City acknowledges the Vista Field Street Design Criteria found in Exhibit E, deviates from the City's standard specifications, the City consents to the design criteria listed in Exhibit E, all other City standard specifications for streets not in conflict with this subsection shall apply. The following additional design standards apply.

7.1.1 The Port agrees to use a WB40 and fire apparatus auto-turn modeling as the Design Vehicles for the design of the streets and intersections within Vista Field except as provided for in Section 7.1.2, below:

7.1.2 The Port agrees to use a WB50 as the Design Vehicle to design the streets and intersections around the primary routes to accommodate the "errant truck." The primary routes are considered to be the main East West road connecting Young Street to Kellogg Street, and the North South road connecting Deschutes to Grandridge.

7.1.3 All buildings shall be maximum 150 feet from a "fire truck staging location" as measured along streets, pedestrian passages, or other publicly accessible open space to the farthest corner of the building.

7.1.4 Fire truck staging areas shall be minimum 20 feet wide in order to allow sufficient room for emergency workers to move around the fire truck with hoses, and other emergency response equipment.

7.1.5 Where the vertical distance between the grade plane and the highest roof surface exceeds 30 feet, approved aerial fire apparatus access roads shall be provided. Aerial fire apparatus access roads shall have a minimum unobstructed width of 26 feet, exclusive of shoulders, in the immediate vicinity of the building or portion thereof. One or more of the required access routes meeting this condition shall be located not less than 15 feet and not greater than 30 feet from the building, and shall be positioned parallel to one entire side of the building.

7.1.6 Turning radii into side streets shall meet City design standards as measured from the driving lane of one street into the side street (not the actual radius of the street curb).

7.1.7 Intersection of 20-foot fire lane access routes in alley locations shall require dedication of additional 10-foot by 10-foot triangle rights-of-way areas to assure safe and efficient circulation of emergency vehicles. See attached Exhibit G for an example of this requirement.

7.1.8 The non-City alleys function as fire apparatus access roads with 20-foot minimum clearance requirements and signage at the intersection of the non-City alleys and City rights-of-way shall provide clear notice of this fire apparatus access road requirement. "No Parking Fire Lane" signs shall be placed on alternating sides of the alleys spaced at a maximum distance of 75 feet between signs. "No Parking Fire Lane" signs shall be designed in accordance with COK Standard Detail DWG. NO. 7-5.

7.2 **Park Impact Fees.** The Parties acknowledge the City adopted a Park Impact Fee in 2018 and the property is in Service Area #1. The Port and their successors in interest agree to pay the Park Impact fee determined by the City at the time a complete application for a development permit is submitted to the City.

7.3 **Fire Protection Facilities Department Impact Fees.** The Parties acknowledge the City adopted a Fire Protection Facilities Impact Fee in 2025 and further acknowledge the Fire Protection Facilities Impact Fee currently only applies to the Southridge area of the city. If the City duly enacts an ordinance enlarging Fire Protection Facilities Impact Fee area to encompass the entire City, or creating another standalone zone that encompasses the Vista Field development area, then the Port and their successors in interest agree to pay the Fire Protection Facilities Impact fee determined by the City at the time a complete application for a development permit is submitted to the City.

8. VESTING.

8.1 **Effect of Development Agreement on Subsequent Development Regulations.** Development regulations adopted subsequent to the Agreement Effective Date, shall not be applicable to Vista Field Property, except as otherwise provided in this Agreement or as may be required by subsequently adopted state or federal statutes.

8.2 **Vested Rights.** All regulations in existence on Agreement Effective Date shall be applicable to the development of the Property, including: those provisions of Chapters 36.70A (Growth Management) and 58.17 RCW (Plats, Subdivisions and Dedications), as supplemented by the design standards contained in Kennewick Municipal Code (KMC), including but not limited to KMC 18.80, and the sections KMC 18.12, 18.24 and 18.36 as referenced in Section 4.2, the Final Vista Field

Redevelopment Master Plan, and other provisions of this Agreement attached hereto as Exhibits C, D, E, F and G; all applicable KMC sections, the City Comprehensive Plan, as well as all other City rules, regulations, standards and specifications applicable to Vista Field and in effect on the Agreement Effective Date. Unless otherwise stated herein with respect to Traffic Impact Fees and Park Impact Fees and Fire Protection Facilities Impact Fees, this Agreement vests for the Port, its successors and assigns, and the Property to the regulations in effect on the Agreement Effective Date and as set forth herein for the term of this Agreement, and for the reasonable build-out period for improvements with building permits issued prior to the termination of the Agreement.

8.3 **Exception to Vesting/Serious Threat to Public Health.** In the event the City is faced with an unforeseen serious and immediate threat to public health, safety and welfare directly effecting Vista Field Property, the City may, upon notice to the Port, adopt new or different regulations applicable to the property than those established in this Agreement.

9. **AGREEMENT TERM AND EFFECTIVE DATE.** This Agreement shall take effect and be in force upon the last date of the signature of each Party to this Agreement, following the effective date of the City Ordinance approving this Agreement (the "Effective Date"). The Agreement term shall commence on the Effective Date and extend for ten (10) years (the "Agreement Term"). The Agreement Term may be extended by ten-year extensions upon application by the Port and approval by City Council per KMC 18.48, until the Agreement is deemed no longer necessary by both parties.

10. **MINOR PLAN MODIFICATIONS.** The Parties acknowledge that refinement and further development of the Vista Field Master Plan and associated improvements may require modification during the Agreement Term. The Parties shall review and consider requests for minor modifications. Minor modifications require the consent of the City and the Port, which consent shall not be unreasonably withheld. For purposes of this Agreement Section 10, a "minor modification" is a modification in the Master Plan or applicable development regulations that do not require SEPA review.

11. GENERAL PROVISIONS.

11.1 **Default.** In the event either Party fails to perform the terms and provisions of this Agreement, which failure continues uncured for a period of sixty (60) days following written notice from the other Party (unless the Parties have mutually agreed in writing to extend this period) shall constitute a default under this Agreement. Any notice of default shall specify the nature of the alleged default and, where appropriate, the manner in which the alleged default may be satisfactorily cured. If the nature of the alleged default is such that it cannot be reasonably cured within the sixty (60) day period, then the commencement of actions to cure the alleged default within the sixty (60) day period and diligent prosecution of such actions necessary to complete the cure of the alleged default, shall be deemed to be a cure within the sixty (60) day period. Upon a default of this Agreement that is not cured as provided above, the non-defaulting Party may institute legal proceedings to enforce the terms of this Agreement. If the default is cured, then no default exists, and the noticing Party shall take no further action.

11.2 **Extension of Time for Performance.** Notwithstanding anything to the contrary contained in this Agreement, neither Party shall be deemed to be in default where delays and performance or failures to perform are due to war, terrorism, insurrection, strikes or other labor disturbances, walkouts, riots, floods, earthquakes, fires, casualties, acts of God, restrictions imposed or mandated by other governmental entities, enactment of conflicting state or federal laws or regulations, extended appeals by third parties or similar basis for excused performance which are not within the

reasonable control of the party to be excused. Upon the request of either Party, an extension of time for such cause shall be granted in writing for the period of the forced delay, or longer, as may be mutually agreed upon.

11.3 **Governing Law, Remedies and Venue.** This Agreement shall be governed by the laws of the State of Washington. Either Party may, in addition to any other rights or remedies, institute an equitable action to cure correct, or remedy any default; enforce any covenant or agreement set forth herein; enjoin any threatened or attempted violation of the Agreement; enforce by specific performance the obligations and rights of the parties to this Agreement, or obtain any remedies consistent with the foregoing and the purpose and intent of this Agreement; provided, however, in no event shall either Party be entitled to recover from the other Party, either directly or indirectly "damages" in any legal or equitable action. Notwithstanding the foregoing, in the event of a dispute arising out of or relating to this Agreement, whether or not suit or other proceedings are commenced and whether in mediation, arbitration, at trial, on appeal or in administrative proceedings, the substantially prevailing Party shall be entitled to its costs and expenses incurred, including reasonable attorney's fees. Venue for any action shall be in the Superior Court for Benton County, Washington.

11.4 **Dispute Resolution.** The Parties shall attempt to resolve disputes through informal good faith negotiations. Either Party may declare an impasse in an informal negotiation, but only after thirty (30) days following commencement of negotiations.

11.4.1 **Mediation.** Either Party may request mediation before neutral mediator acceptable to both Parties. If a mediator cannot be selected by the Parties, any Party may apply to the Presiding Judge of the Benton County Superior Court for appointment of a mediator. The costs of the mediator shall be borne equally by each Party. Any mediation process shall not delay or preclude commencement of an action in Superior Court for emergency or temporary relief.

11.4.2 **Arbitration.** Disputes not resolved through negotiation or mediation may be resolved by arbitration upon mutual agreement of the Parties. Arbitration shall be before a single arbitrator. The decision of the arbitrator will bind all Parties. If an arbitrator cannot be selected by the Parties, any Party may apply to the Presiding Judge of the Benton County Superior Court for appointment of the arbitrator. The Parties shall share equally the fees and expenses of the arbitrator. The arbitration will be conducted under Chapter 7.06 RCW, and the Superior Court Rules for Mandatory Arbitration (MAR). Any matter not submitted to arbitration may be brought in Superior Court.

11.4.3 This Agreement Section 11.4 shall survive the Agreement Term and shall also apply to resolve any disputes between the Parties arising out of or relating to this Agreement or the transactions contemplated thereby.

11.5 **Construction.** This Agreement has been freely and fairly negotiated by the Parties hereto and has been reviewed and discussed by legal counsel for each of the Parties, each of whom has had the full opportunity to modify the draftsmanship hereof and, therefore, the terms of this Agreement shall be construed and interpreted without any presumption or other rule requiring constructional interpretation against the Party causing the drafting of the Agreement.

11.6 **Complete Agreement and Conflicts.** This Agreement sets forth the entire agreement of the Parties. This Agreement shall be construed as a whole. No amendment, change or modification of any provision of this Agreement shall be valid unless set forth in writing and signed by both Parties. To the extent of any conflict with any City development regulations which may otherwise govern the

Property, the terms and conditions of the development regulations in effect on the Effective Date and this Development Agreement shall prevail.

11.7 **Waiver and Severability.** The failure of either Party to insist upon or enforce strict performance by the other Party of any of the provisions of this Agreement or to exercise any rights or remedies under this Agreement shall not be construed as a waiver or relinquishment of any extent of such Party's right to assert or rely upon any such provisions or rights in that or any other instance; rather, the same shall be and remain in full force and effect. The invalidity or unenforceability of any provision of this Agreement shall not affect the other provisions hereof, and this Agreement shall be construed in all respects as if such invalid or unenforceable provisions were omitted.

11.8 **Binding Effect.** This Agreement shall be recorded against the Property and shall run with the land. Subject only to the express conditions or limitations of this Agreement, the Agreement shall be binding upon and inure to the benefit of the respective successors and assigns of the Parties. Upon assignment of this Agreement or the conveyance of any parcel of the Property to which this Agreement is applicable, the assignee/grantee shall be deemed to assume all rights, obligations and liabilities set forth in this Agreement as they relate to such parcel.

11.9 **Cooperation.** Each Party shall take such action (including, but not limited to the execution, acknowledgement and delivery of documents) as may reasonably be requested by the other Party for the implementation or continuing performance of this Agreement. In the event of any administrative, legal or equitable action or other proceeding instituted by any person not a party to this Agreement challenging the validity of any provision of this Agreement, or any subsequent action taken consistent with this Agreement, the Parties shall cooperate in defending such action or proceeding to settlement or final judgment, including all appeals. Each party shall select its own legal counsel and retain such counsel at its own expense.

11.10 **Transfer or Assignment.**

11.10.1 The Port may assign or transfer all or any portion of its interests, rights, obligations or responsibilities under this Agreement, including all development approvals and all subsequent actions, to third parties acquiring an interest in the Property or any portion thereof, including, without limitation, purchasers, or long-term ground lessees of individual lots, tracts, parcels or any lots, homes or facilities comprising a portion of the Property.

11.10.2 Any such transfer shall not release Port from its obligations and responsibilities under this Agreement unless the City has consented to such transfer in writing. In the event of a request for consent to a transfer, the City's consent shall not be unreasonably withheld, conditioned or delayed. Provided, in the event City consent is obtained for a transfer, any transfer agreement or document may (i) release Port from obligations under this Agreement, including development approvals and any subsequent actions, that pertain to the portion of the Property being transferred, provided the transferee expressly assumes Port's obligations and responsibilities; (ii) transfer to the transferee all vested rights to improve that portion of the Property being transferred; and, (iii) may address any other matter deemed by Port or the City to be necessary or appropriate in connection with the transfer or assignment. Written notice of any proposed transfer or assignment for which consent from the City is sought shall be mailed to the City in the manner set forth in this Agreement at least thirty (30) days in advance of the proposed date of transfer. Failure of the City to respond within the thirty (30)-day period after receipt of a request by Port for such consent shall be

deemed to be the City's approval of the transfer in question. All benefits and burdens to the Property are intended to and shall run with the land and shall be enforceable upon and for the benefit of subsequent owners and successors in interest to all or any portion of the Property.

11.11 **Effect of Development Agreement on City Rates and Fees.** Nothing in this Agreement shall prevent the City from modifying standard City-wide rates and fees applied equally throughout the City, and also applicable to Vista Field, during the term of this Agreement, unless specifically set forth in this Agreement.

11.12 **No Public Official Liability.** No provision of this Agreement and any authority granted by this Agreement is intended to create or result in any personal liability for any public official or employee or agent of the City or Port, nor shall any provision or provisions of this Agreement be construed to create any such liability.

11.13 **Notices.** Notices under this Agreement shall be in writing and, unless otherwise required by law, may be delivered (1) personally; (2) by U.S. mail, certified or registered; or (3) by a nationally recognized overnight courier service. Mailed notices shall be deemed effective on the third day after deposited as registered or certified mail, postage prepaid, directed to the other party at the address shown below.

Port: Chief Executive Officer
350 Clover Island Drive, Suite 200
Kennewick WA 99336

City: City Manager
210 W. 6th Avenue
Kennewick WA 99336

Couriered notices shall be deemed delivered when the courier's records indicate that delivery has occurred. Either party may change its address for notices by written notice to the other.

11.14 **Warranty of Authority.**

11.14.1 The Port hereby warrants to the City that the undersigned is authorized to execute this Agreement and to bind the port and the Property.

11.14.2 The City has authority under Chapter 36.70B RCW to enter this as a proper exercise of municipal police power and contract authority. This Agreement is entered into pursuant to such authority. The city warrants that the undersigned Mayor has authority and is authorized to enter into this Agreement.

IN WITNESS WHEREOF, the parties hereto executed this Agreement on the below dates.

CITY OF KENNEWICK

Jason McShane, Mayor

DATE: _____

Attest:

City Clerk

Approved as to form:

City Attorney

PORT OF KENNEWICK

Ken Hohenberg, Port Commission President

DATE: _____

EXHIBIT A – VISTA FIELD PROPERTY LEGAL DESCRIPTION**PARCEL 1**

REAL PROPERTY LOCATED IN SECTION 32, TOWNSHIP 9 NORTH, RANGE 29 EAST, WILLAMETTE MERIDIAN, CITY OF KENNEWICK, BENTON COUNTY, WASHINGTON BEING MORE PARTICULARLY DESCRIBED AS FOLLOWS:

BEGINNING AT THE SOUTHEAST CORNER OF THE NORTHEAST QUARTER OF SAID SECTION 32; THENCE NORTH 00°05'15" EAST, 891.82 FEET ALONG THE EAST LINE OF SAID NORTHEAST QUARTER; THENCE NORTH 89°54'25" WEST, 162.33 FEET TO THE SOUTHWEST CORNER OF LOT 2 OF SHORT PLAT NO. 1333 AS RECORDED IN VOLUME 1 OF SHORT PLATS, PAGE 1333, RECORDS OF BENTON COUNTY, SAID POINT IS ALSO AN ANGLE POINT IN THE NORTHERLY LINE OF BLOCK 1 OF THE PLAT OF VISTA INDUSTRIAL PARK AS RECORDED IN VOLUME 14 OF PLATS, PAGE 56, RECORDS OF BENTON COUNTY AND THE TRUE POINT OF BEGINNING;

THENCE SOUTH 45°11'01" WEST, 2042.89 FEET ALONG THE NORTHWESTERLY LINE OF SAID BLOCK 1 TO THE NORTHWEST CORNER OF THAT PARCEL SHOWN ON RECORD OF SURVEY RECORDED IN VOLUME 1 OF SURVEYS, PAGE 2320, RECORDS OF BENTON COUNTY; THENCE SOUTH 44°48'56" EAST, 200.00 FEET ALONG THE SOUTHWESTERLY LINE OF SAID PARCEL TO THE NORTHWESTERLY LINE OF OKANOGAN AVENUE; THENCE SOUTH 45°11'04" WEST, 30.00 FEET ALONG SAID NORTHWESTERLY LINE TO THE SOUTHEAST CORNER OF PARCEL "A" AS SHOWN ON RECORD OF SURVEY RECORDED IN VOLUME 1 OF SURVEYS AT PAGE 1611, RECORDS OF BENTON COUNTY; THENCE NORTH 44°48'56" WEST, 255.75 FEET TO THE MOST NORTHERLY CORNER OF SAID PARCEL "A"; THENCE SOUTH 45°11'04" WEST, 670.00 FEET ALONG THE NORTHWESTERLY LINES OF PARCEL "A" AND PARCEL "B" OF SAID SURVEY TO THE NORTHWEST CORNER OF SAID PARCEL "B"; THENCE SOUTH 44°48'56" EAST, 55.75 FEET ALONG THE SOUTHWESTERLY LINE OF SAID PARCEL "B" TO THE NORTHWESTERLY LINE OF WEST DESCHUTES AVENUE; THENCE SOUTH 45°11'04" WEST, 494.70 FEET ALONG SAID NORTHWESTERLY LINE TO THE SOUTHEAST CORNER OF THAT PARCEL OF LAND SHOWN ON RECORD OF SURVEY RECORDED IN VOLUME 1 OF SURVEYS, PAGE 2094, RECORDS OF BENTON COUNTY; THENCE NORTH 44°48'56" WEST, 139.19 FEET TO THE NORTHEAST CORNER OF SAID PARCEL; THENCE SOUTH 45°11'04" WEST, 323.30 FEET TO THE NORTHWEST CORNER OF SAID PARCEL; THENCE SOUTH 44°48'56" EAST, 139.19 FEET TO THE SOUTHWEST CORNER OF SAID PARCEL, SAID POINT BEING ON THE NORTHWESTERLY LINE OF WEST DESCHUTES AVENUE; THENCE SOUTH 45°11'04" WEST, 739.11 FEET ALONG SAID NORTHWESTERLY LINE TO A POINT IN THE EASTERLY LINE OF PARCEL 7 AS SHOWN ON RECORD OF SURVEY RECORDED IN VOLUME 1 OF SURVEYS, PAGE 522, RECORDS OF BENTON COUNTY; THENCE NORTH 44°48'56" WEST, 700.00 FEET ALONG SAID EASTERLY LINE TO AN ANGLE POINT IN SAID LINE, SAID POINT BEING THE SOUTHWEST CORNER OF LOT 4 OF THE PLAT OF WESTHAVEN BLOCK TWO ACCORDING TO THE PLAT THEREOF RECORDED IN VOLUME 15 OF PLATS, PAGE 75, RECORDS OF BENTON COUNTY; THENCE NORTH 45°11'04" EAST, 700.00 FEET ALONG THE SOUTHEASTERLY LINE OF SAID PLAT TO THE SOUTHEAST CORNER OF LOT 12 OF SAID PLAT; THENCE NORTH 44°48'56" WEST, 508.22 FEET ALONG THE EASTERLY LINE OF SAID PLAT TO THE NORTHEAST CORNER OF LOT 10 OF SAID PLAT, SAID POINT BEING ON THE

SOUTHEASTERLY LINE OF GRANDRIDGE BLVD.; THENCE NORTH 45°11'04" EAST, 60.00 FEET ALONG SAID SOUTHEASTERLY LINE TO THE NORTHWEST CORNER OF TRACT "A" AS SHOWN ON RECORD OF SURVEY RECORDED IN VOLUME 1 OF SURVEYS, PAGE 2339, RECORDS OF BENTON COUNTY; THENCE SOUTH 44°48'56" EAST, 407.01 FEET ALONG THE SOUTHWESTERLY LINE OF SAID TRACT "A" AND TRACT "B" OF SAID SURVEY TO THE MOST SOUTHERLY CORNER OF SAID TRACT "B"; THENCE NORTH 45°11'04" EAST, 797.11 FEET ALONG THE SOUTHEASTERLY LINE OF SAID TRACT "B" TO THE MOST EASTERLY CORNER THEREOF; THENCE SOUTH 44°48'56" EAST, 101.21 FEET; THENCE NORTH 45°11'04" EAST, 700.00 FEET TO THE MOST SOUTHERLY CORNER OF PARCEL 3 AS SHOWN ON RECORD OF SURVEY RECORDED IN VOLUME 1 OF SURVEYS, PAGE 521, RECORDS OF BENTON COUNTY; THENCE CONTINUING NORTH 45°11'04" EAST, 2042.89 FEET ALONG THE SOUTHEASTERLY LINE OF SAID PARCEL 3 AND THE SOUTHEASTERLY LINES OF SHORT PLAT NO. 1333 AND SHORT PLAT NO. 1644 AS RECORDED IN VOLUME 1 OF SHORT PLATS AT PAGES, 1333 AND 1644, RECORDS OF BENTON COUNTY TO THE MOST WESTERLY CORNER OF LOT 2 OF SAID SHORT PLAT NO. 1333; THENCE SOUTH 44°48'56" EAST, 700.00 FEET ALONG THE SOUTHWESTERLY LINE OF SAID LOT 2 TO THE TRUE POINT OF BEGINNING.

CONTAINS 69.90 ACRES.

PARCEL 2

LOT 2, SHORT PLAT NO. 1333, RECORDED IN THE OFFICE OF THE COUNTY AUDITOR IN VOL. 1 OF SHORT PLATS, PAGE 1333. CONTAINS 5.58 ACRES.

PARCEL 3

LOT 3, SHORT PLAT 3336, ACCORDING TO THE SHORT PLAT THEREOF RECORDED IN VOLUME 1 OF SHORT PLATS, PAGE 3336, RECORDS OF BENTON COUNTY, WASHINGTON
CONTAINS 2.85 ACRES

PARCEL 4

LOT 2, SHORT PLAT 3336, ACCORDING TO THE SHORT PLAT THEREOF RECORDED IN VOLUME 1 OF SHORT PLATS, PAGE 3336, RECORDS OF BENTON COUNTY, WASHINGTON
CONTAINS 3.14 ACRES

PARCEL 5

THAT PORTION OF PARCEL 3 OF RECORD SURVEY NO. 1-521 DESCRIBED AS FOLLOWS:
BEGINNING AT THE MOST SOUTHERLY CORNER OF SAID PARCEL 3; THENCE NORTH 45°11'04" EAST ALONG THE SOUTHEASTERLY BOUNDARY OF SAID PARCEL FOR 193.31 FEET; THENCE NORTH 77°09'37" WEST 361.22 FEET TO A POINT ON THE SOUTHWESTERLY BOUNDARY OF SAID PARCEL 3; THENCE SOUTH 44°48'56" EAST ALONG SAID SOUTHWESTERLY BOUNDARY 305.40 FEET TO THE POINT OF BEGINNING.
TOGETHER WITH THE FOLLOWING DESCRIBED PARCEL:

BEGINNING AT THE MOST SOUTHERLY CORNER OF SAID PARCEL 3; THENCE SOUTH 45°11'04" WEST, 700.00 FEET; THENCE NORTH 44°48'56" WEST, 101.21 FEET TO THE MOST EASTERLY CORNER OF TRACT "B" AS SHOWN ON RECORD OF SURVEY RECORDED IN VOLUME 1 OF SURVEYS, PAGE 2339, RECORDS OF BENTON COUNTY; THENCE NORTH 44°48'56" WEST, 406.52 FEET ALONG THE NORTHEASTERLY LINE OF SAID TRACT "B" AND TRACT "A" OF SAID SURVEY TO A POINT ON THE SOUTHEASTERLY LINE OF GRANDRIDGE BLVD., SAID POINT ALSO BEING ON THE ARC OF A 1031.00 FEET RADIUS CURVE (RADIUS POINT BEARS NORTH 44°49'51" WEST); THENCE NORTHERLY, 513.53 FEET ALONG THE ARC OF SAID CURVE AND ALONG THE SAID SOUTHEASTERLY LINE OF GRANDRIDGE BLVD. THROUGH A CENTRAL ANGLE OF 28°32'17" TO THE SOUTHWEST CORNER OF LOT 1, BLOCK 3 COLONNADE BUSINESS PARK AS SHOWN ON BINDING SITE PLAN NO. 3386 AS RECORDED IN VOLUME 1 OF SURVEYS, PAGE 3386, RECORDS OF BENTON COUNTY; THENCE SOUTH 77°09'13" EAST (SOUTH 77°09'37" EAST, RECORD), 387.50 FEET ALONG THE SOUTHERLY LINE OF SAID RECORD OF SURVEY AND THE SOUTHWESTERLY LINE OF A PARCEL AS SHOWN ON RECORD OF SURVEY RECORDED IN VOLUME 1 OF SURVEYS, PAGE 3785, RECORDS OF BENTON COUNTY TO A POINT ON THE SOUTHWESTERLY LINE OF PARCEL 3 OF SAID RECORD SURVEY NO. 1-521; THENCE SOUTH 44°48'56" EAST, 305.72 FEET (305.40 FEET RECORD) TO THE POINT OF BEGINNING. CONTAINS 9.12 ACRES.

PARCEL 6

TRACT B OF RECORD SURVEY #2339 DESCRIBED AS FOLLOWS: THAT PORTION OF THE NORTHEAST QUARTER OF THE SOUTHWEST QUARTER OF SECTION 32, TOWNSHIP 9 NORTH, RANGE 29 EAST, W.M., CITY OF KENNEWICK, BENTON COUNTY, WASHINGTON, DESCRIBED AS FOLLOWS: COMMENCING AT THE MOST WESTERLY CORNER OF A 10 ACRE PARCEL AS DEPICTED ON A SURVEY RECORDED UNDER AUDITOR'S FILE NUMBER 838693 AND FILED IN VOLUME ONE OF SURVEYS, AT PAGE 662, RECORDS OF SAID COUNTY. THENCE NORTH 45°11'04" EAST ALONG THE SOUTHEASTERLY RIGHT-OF-WAY LINE OF A CITY STREET KNOWN AS GRANDRIDGE BLVD. 60.00 FEET. THENCE SOUTH 44°48'56" EAST 307.01 FEET TO THE TRUE POINT OF BEGINNING. THENCE NORTH 45°11'04" EAST 797.11 FEET. THENCE SOUTH 44°48'56" EAST ALONG THE NORTHEASTERLY LINE OF SAID 10 ACRE PARCEL 100.00 FEET. THENCE SOUTH 45°11'04" WEST 797.11 FEET. THENCE NORTH 44°48'56" WEST 100.00 FEET TO THE TRUE POINT OF BEGINNING.

TOGETHER WITH AND SUBJECT TO EASEMENTS, RESERVATIONS, COVENANTS, AND RESTRICTIONS OF RECORD AND IN VIEW.

CONTAINS 1.83 ACRES.

PARCEL 7

THAT PORTION OF PARCEL 7 OF RECORD SURVEY 1-522, AS ON FILE WITH THE BENTON COUNTY AUDITOR, LOCATED IN THE SOUTHWEST QUARTER OF SECTION 32, TOWNSHIP 9 NORTH, RANGE 29 EAST, W.M., BENTON COUNTY, WASHINGTON, DESCRIBED AS FOLLOWS:

COMMENCING AT THE MONUMENTED INTERSECTION OF THE CITY STREETS KNOWN AS NORTH YOUNG STREET AND WEST

DESCHUTES AVENUE, SAID POINT BEING THE SOUTHWEST CORNER OF SAID PARCEL 7; THENCE SOUTH 89°16'47" EAST 30.00 FEET; THENCE NORTH 0°28'48" EAST 40.00 FEET TO THE INTERSECTION OF THE EASTERLY AND NORTHERLY RIGHTS-OF-WAY OF SAID STREETS RESPECTIVELY, AND THE TRUE POINT OF BEGINNING;

THENCE CONTINUING NORTH 0°28'48" EAST ALONG SAID EASTERLY RIGHT OF WAY 347.50 FEET; THENCE NORTH 45°11'04" EAST 690.98 FEET TO A POINT ON THE EASTERLY BOUNDARY OF SAID PARCEL 7; THENCE SOUTH 44°48'56" EAST ALONG SAID EASTERLY BOUNDARY 600.00 FEET TO A POINT ON SAID NORTHERLY RIGHT-OF-WAY OF DESCHUTES AVENUE, SAID POINT IS NORTH 44°48'56" WEST 40.00 FEET FROM THE SOUTHEAST CORNER OF SAID PARCEL 7; THENCE SOUTH 45°11'04" WEST ALONG SAID NORTHERLY RIGHT-OF-WAY 250.00 FEET; THENCE NORTH 44°48'56" WEST 100.00 FEET; THENCE SOUTH 45°11'04" WEST 393.74 FEET TO A POINT ON SAID NORTHERLY RIGHT-OF-WAY, SAID POINT BEING ON A CURVE TO THE RIGHT, THE RADIUS POINT OF WHICH BEARS NORTH 15°29'00" WEST 780.00 FEET; THENCE WESTERLY ALONG SAID CURVE AND SAID NORTHERLY RIGHT-OF-WAY 220.59 FEET; THENCE NORTH 89°16'47" WEST ALONG SAID NORTHERLY RIGHT OF WAY 170.82 FEET TO THE TRUE POINT OF BEGINNING.
CONTAINS 9.87 ACRES.

EXHIBIT B – VISTA FIELD PROPERTY PARCEL MAP

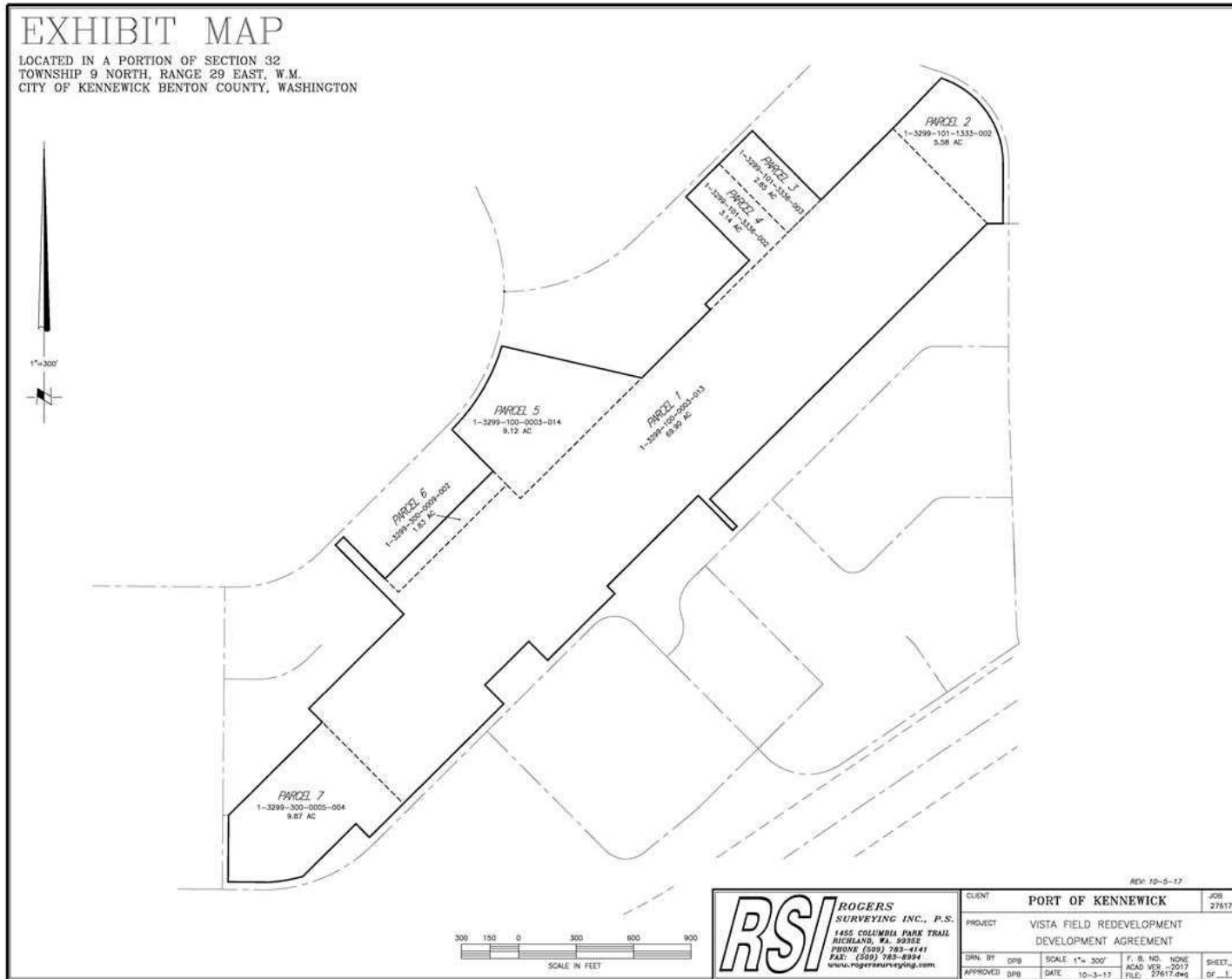

EXHIBIT C – VISTA FIELD MASTER PLAN 2017

EXHIBIT D – VISTA FIELD MASTER PLAN - LAYOUT



VISTA FIELD
KENNEWICK, WASHINGTON
DUNKY PLATTEN - ZIGLER & COMPANY
NOVEMBER 2014
UPDATED MARCH 2016

MAP
BASE MAP
SCALE: 1" = 100'
1408

EXHIBIT E

Vista Field Roadway Design Criteria Elements

Street Types	
Commercial Street	36' curb to curb, (2) 10' lanes, (2) 8' parking lanes, Sharrows
Private Shared Residential Street/Woonerf	20' minimum
Private Alley	20' minimum.
Variants – i.e. one-way and median	2' minimum width, 12' lanes/8' parking/8' Grasscrete, bike lanes to be Sharrows
Lane Widths	10' minimum, 11' minimum adjacent to a curb
Parking Lane width	8' typical, 7' minimum
Bike Lanes	Sharrows and limited signage as appropriate
Bike Racks & Other Street Furniture	As needed between tree wells
Sidewalks	Typically 10' minimum width scored concrete patterns
Right-of-Way	Back of Sidewalk
Street Trees	Columnar trees 4.5' from face of curb with 4' square tree wells space accordingly (approximately 30' on center) to avoid impacting street light throw
Crosswalk Treatments	Signing, striping marks, Medians, Raised X-walk or Intersection, Curb Extensions, and Beacons all acceptable
Street Lighting	Decorative Lighting similar to Phase #1 lighting installed on Crosswind & Vista Field boulevards in 2019-2021.
Type	LED
Wattage	84 watts at key intersections and pedestrian crossings, 27 watts all other locations
Color Temperature	3,000K
Mounting Heights	16.5' total pole height
Spacing	120' (60' staggered across the street)
Baskets and/or Banners	Poles are designed to accommodate but not planned to install
Curb Returns	15' typical, 5' minimum
Driveway Types Allowed	Special design details encompassing the 10' sidewalk coupled with City of Kennewick Std. Detail 2-9 (sheet 8 of 10) "Curb Tight Sidewalk Dropback Driveway"
Intersection & Commercial D/W Spacing	155' typical, 105' minimum. Propose using 75' spacing (center to center for areas with private alley/shared residential street/private alley
Intersections	NACTO raised intersections at key intersections including curb extensions, concrete paving, and bollards. Curb Extensions to be used on busiest intersections when possible after AutoTurn is run. Provide for future signal at Grandridge Intersection and South Deschutes entry by providing junction boxes and conduit.
Intersection Visibility & Restrictions	Intersection of (2) City rights of way – Parking restricted with 20' of bulb-out point of curvature (identified in Exhibit E-1) to ensure adequate visibility and enhance KFD apparatus circulation. Intersection of (1) City right of way and alley or shared residential street (Woonerf) – Parking restricted based upon 115' vision triangle to ensure adequate visibility and enhance KFD apparatus circulation. (identified in Exhibit E-2)
Speed Limits	20 MPH. Set sight distance and spacing accordingly.

EXHIBIT E

Vista Field Roadway Design Criteria Elements

Parking	Parallel. If diagonal then consider use of back-in, Plan for pay parking and signage but try to avoid excess signage.
Minimum Horizontal Curve Radii	Probable is 175' - Should be based on design vehicle using 10' lanes. Smaller radii when proven to work using AutoTurn with WB 40 design vehicle.
Types of traffic control	AWSC, TWSC, Yield, No signage
Special Signage District	Street signage deviation for typical City standard allowed, provided compliance with NACTO/MUTCD standards
Traffic Calming Features Allowed	NACTO raised intersections, Traffic Circles, Chicanes, Curb Extensions, Neckdowns, Special Paving/Marking treatments
Turnarounds	Cul-de-sac and other designs as approved by PW & Fire Marshall

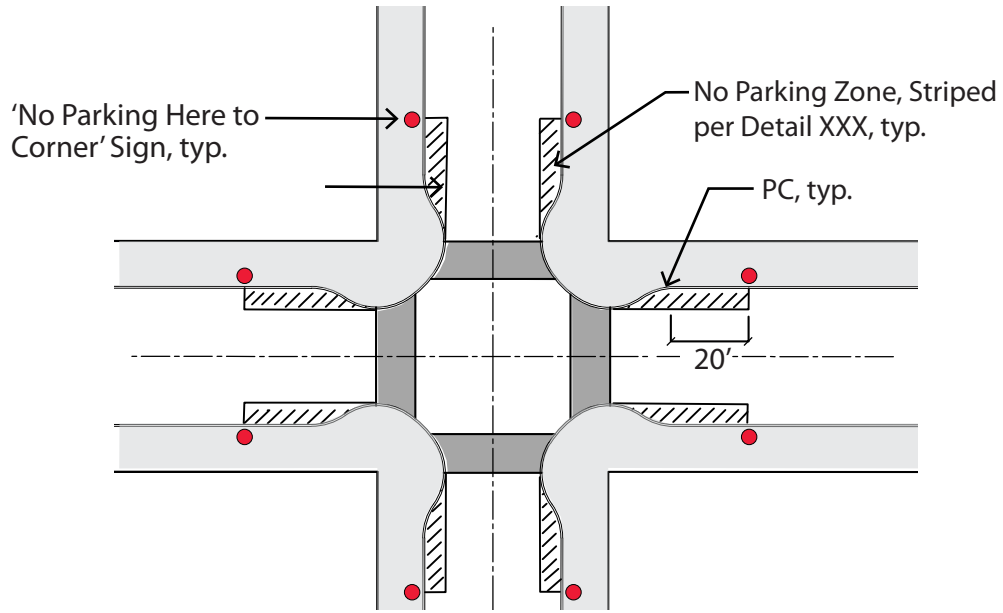

**20' No Parking Setback
from PC per COK**

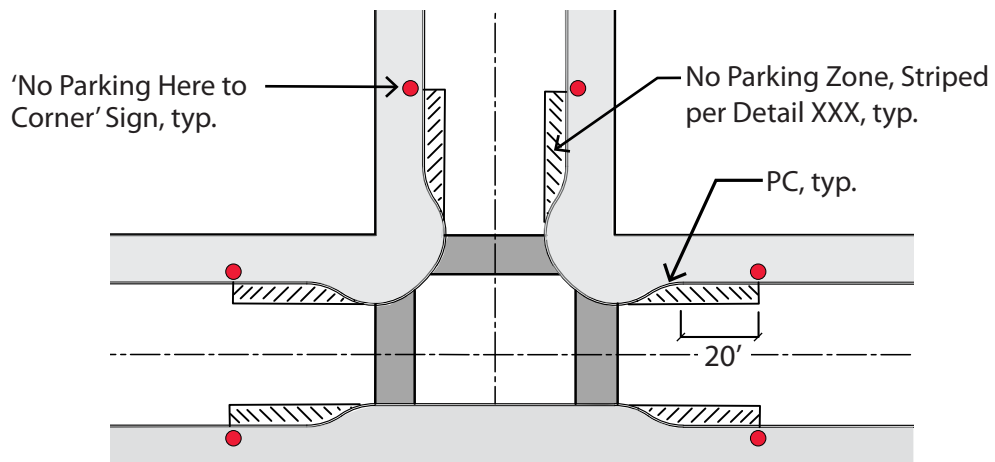

VISTA FIELD
CURB BULB WITH NO PARKING SETBACK
ENGINEERING DEPARTMENT

DATE 10/25
DWN DCS
REV X/XX
CHK LWP
SCALE NTS

DWG. NO.
FIG
1

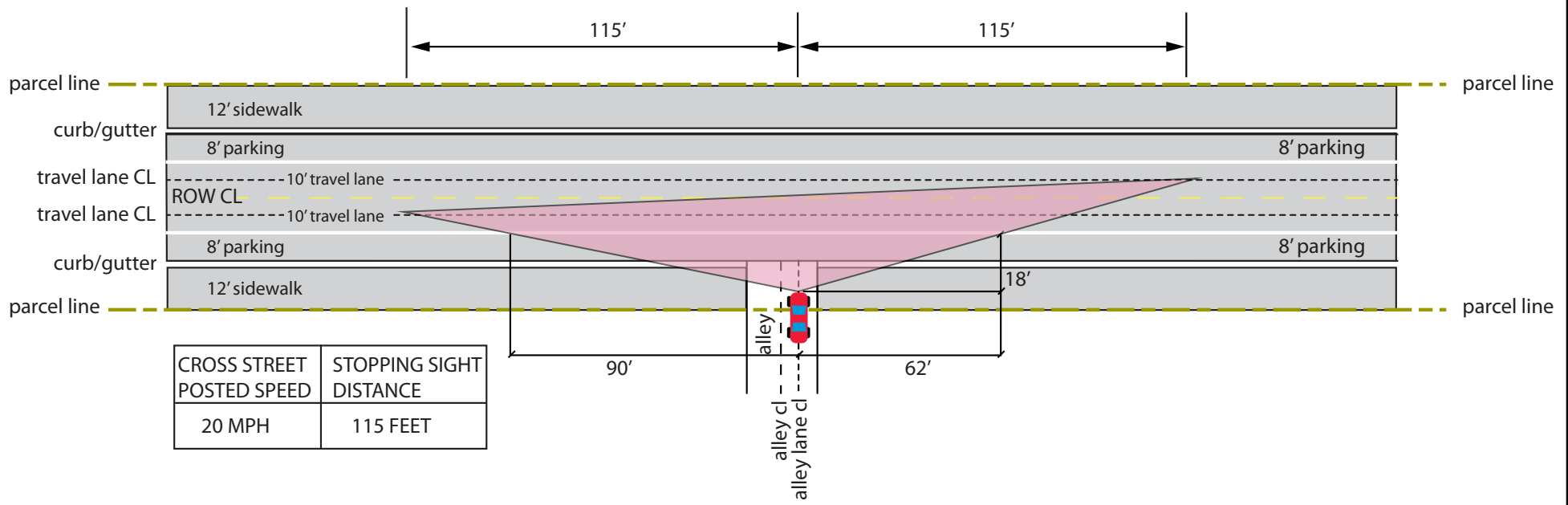

**VISTA FIELD
CLEAR SIGHT TRIANGLE
ENGINEERING DEPARTMENT**

DATE 10/25
DWN DCS
REV X/XX
CHK LWP
SCALE NTS

DWG. NO.
**FIG
2**

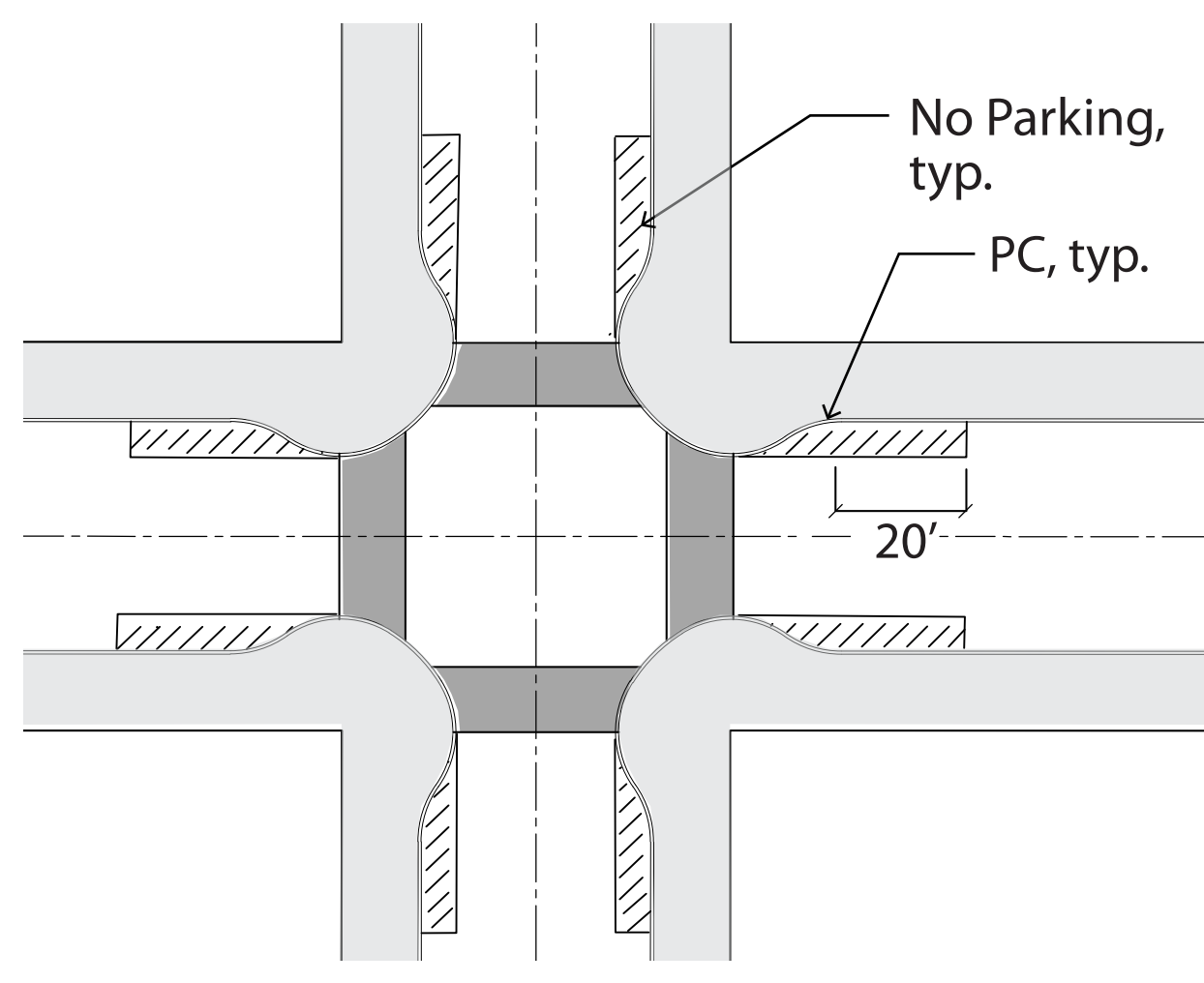

20' No Parking Setback from PC per COK

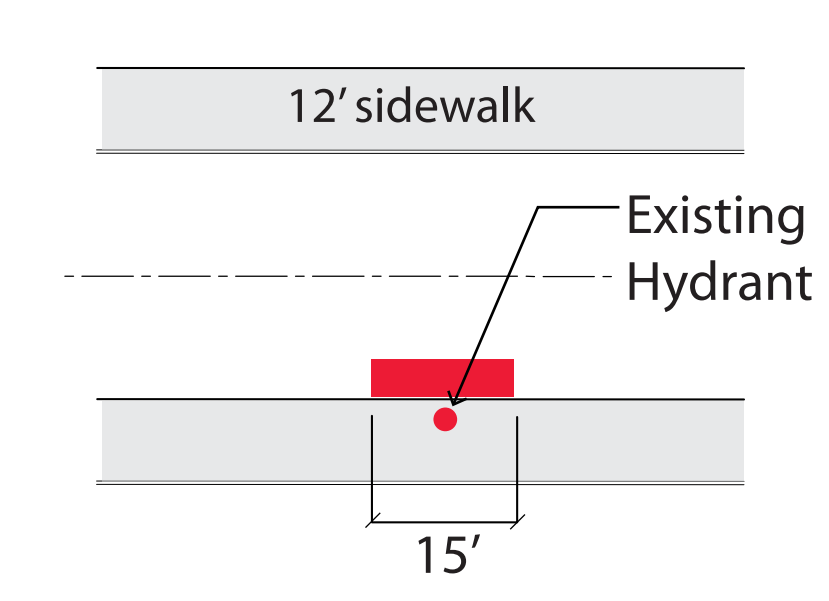

15' No Parking Setback from Existing Hydrant per IFC

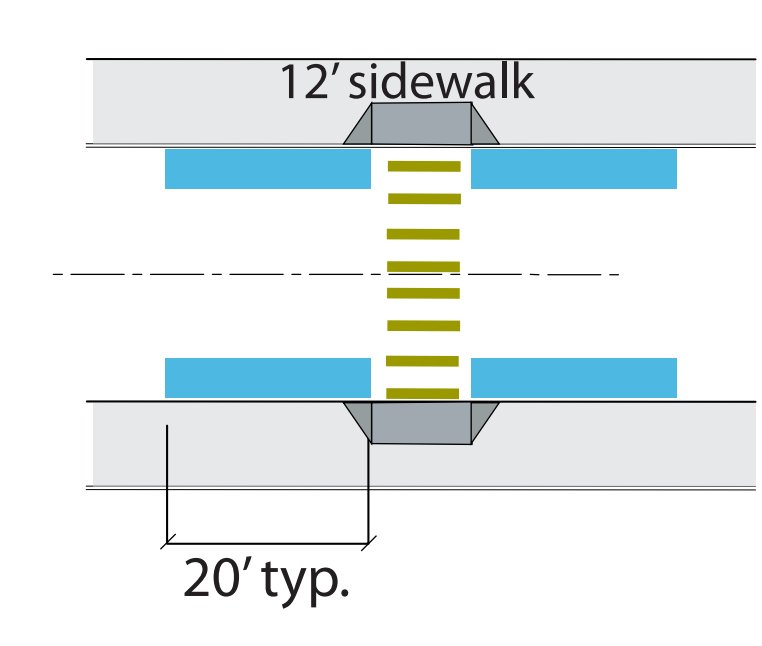

20' No Parking Setback from Crosswalk per MUTCD

Legend

- No Parking per Sight Triangle - See Detail
- Existing Hydrant Location
- No Parking per IFC 15' Clear Along Curbline
- No Parking Setback from Crosswalk - See Detail
- No Parking per COK Offset from PC - See Detail
- No Parking in Transition Zone (Multiple Regulations)
- No Parking per Autoturn - See Exhibit

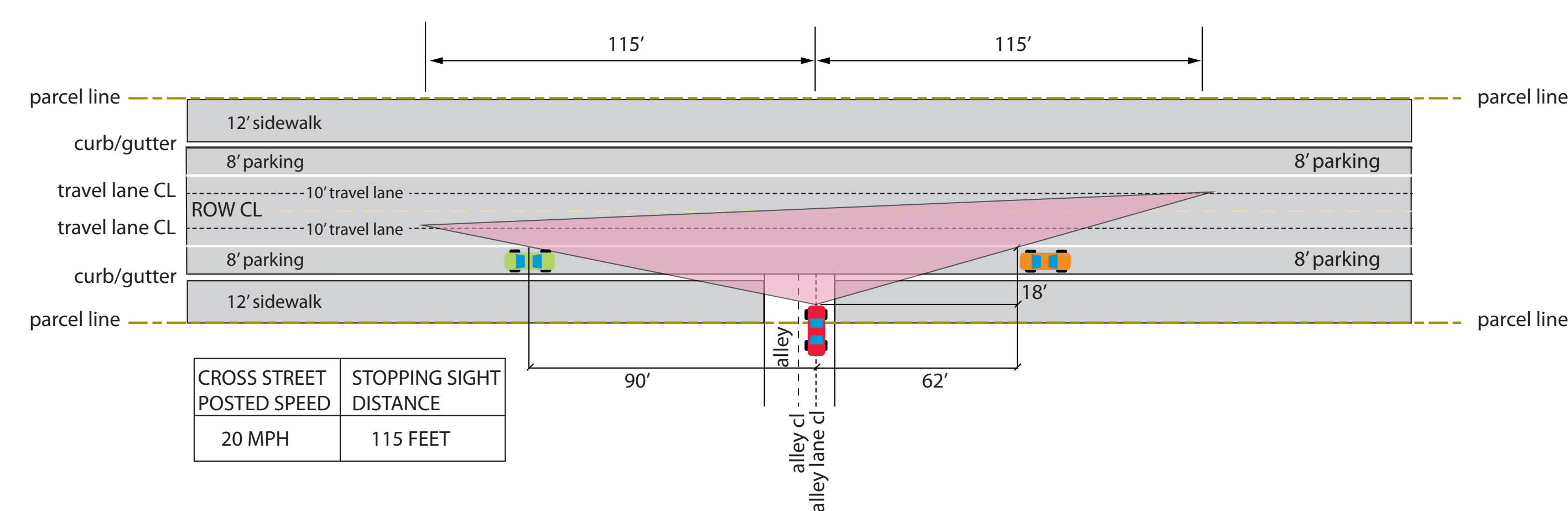
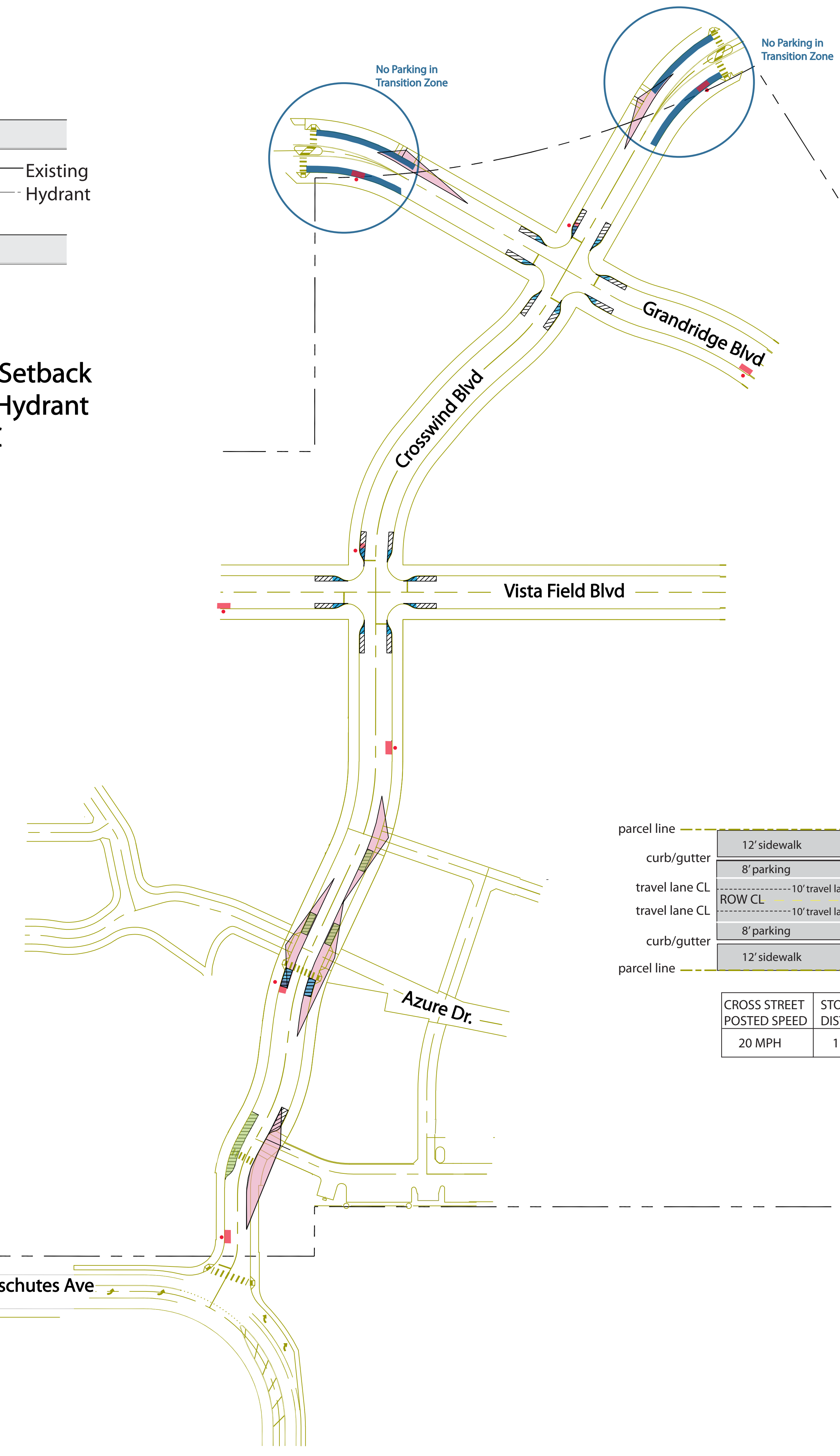

Sight Triangle
City ROW to Private Intersection

Legend

- Existing Fire Hydrant
- ▨ No Parking per Regulatory Overlays

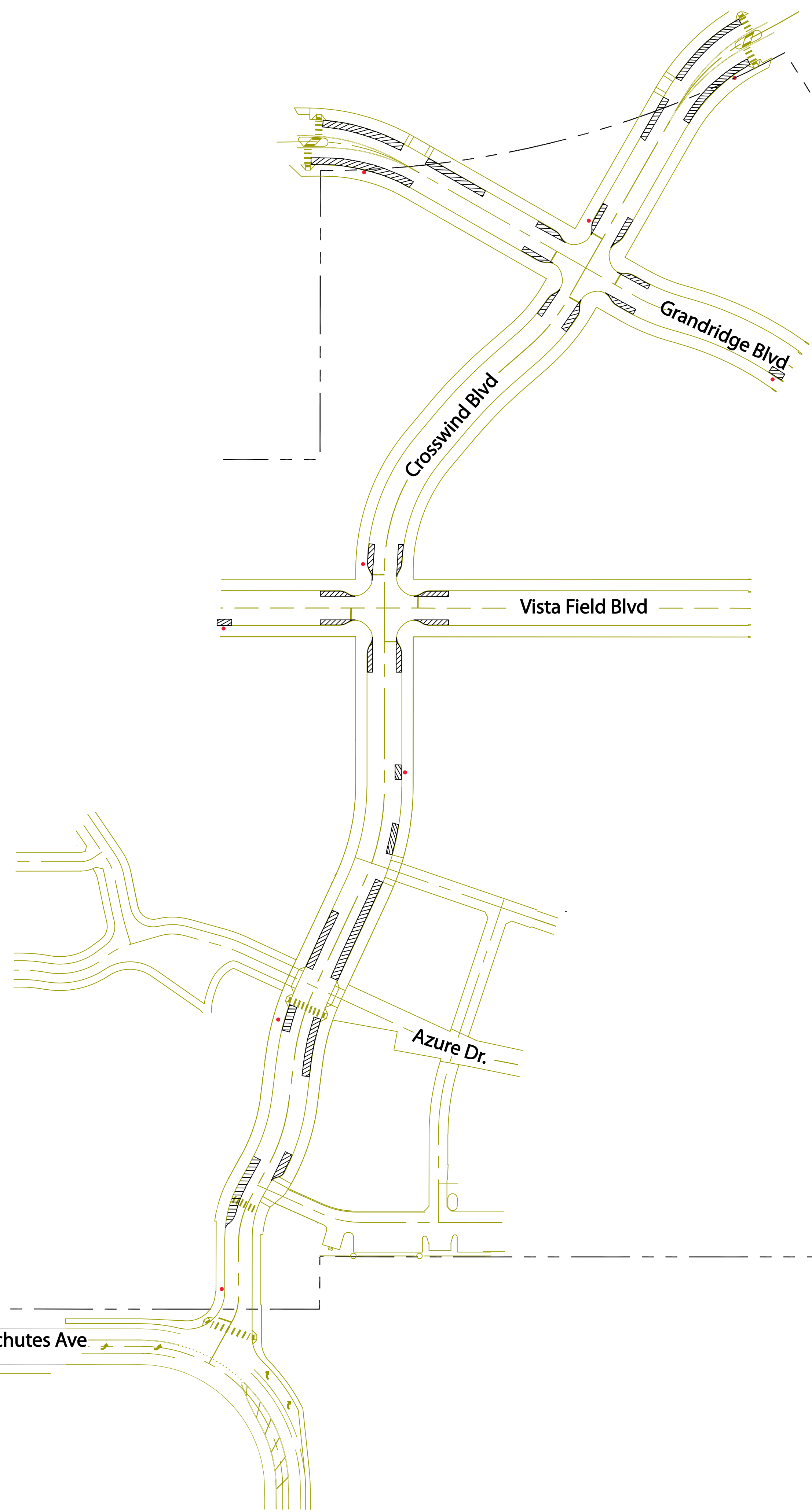

Vista Field No Parking Exhibit

No Parking Areas

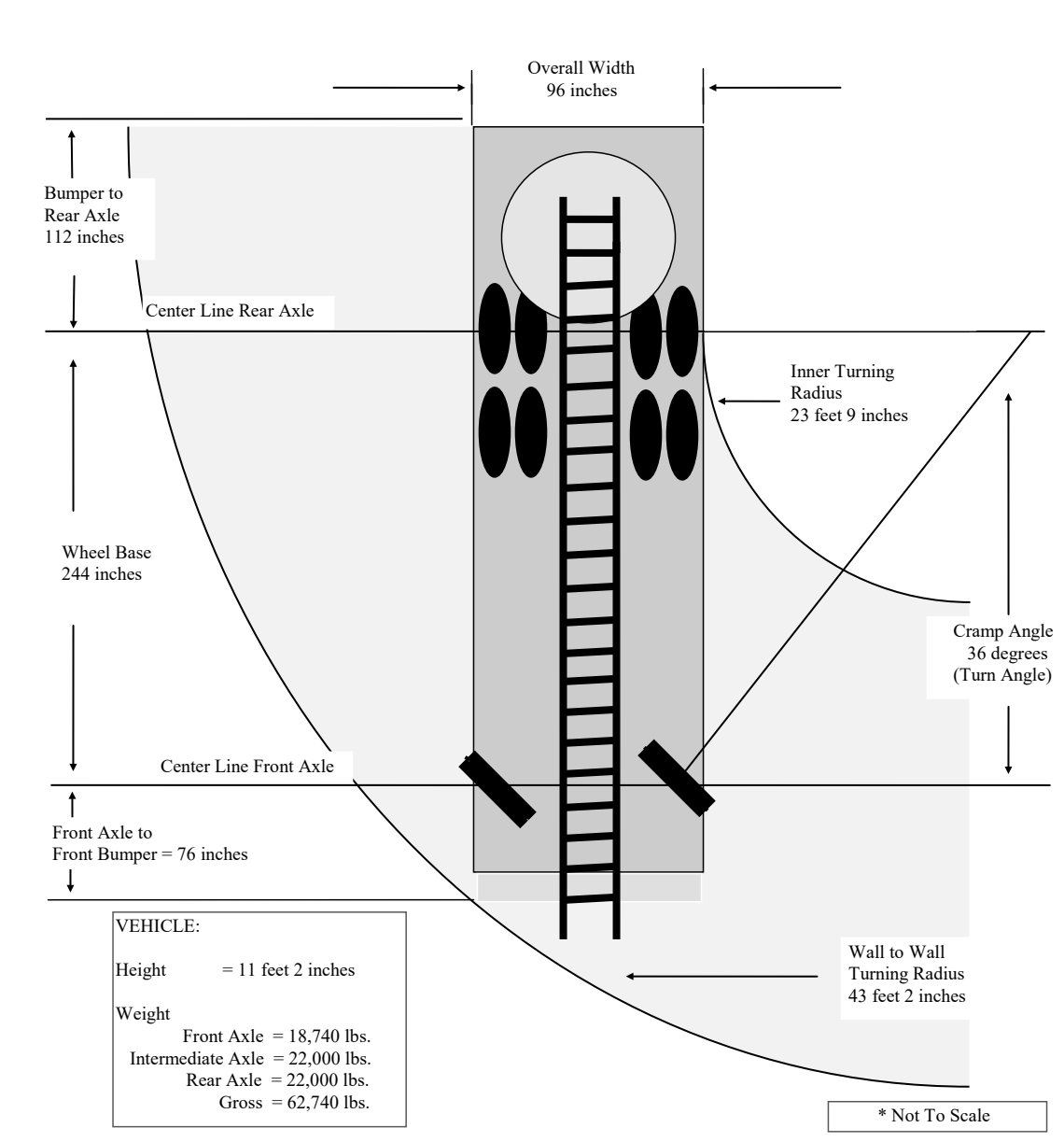

**Kennewick Fire Apparatus
Turning Radius Specifications**

Legend

- Existing Fire Hydrant
- ▨ No Parking per Regulatory Overlays
- 🚒 COK Fire Truck Turning Movement

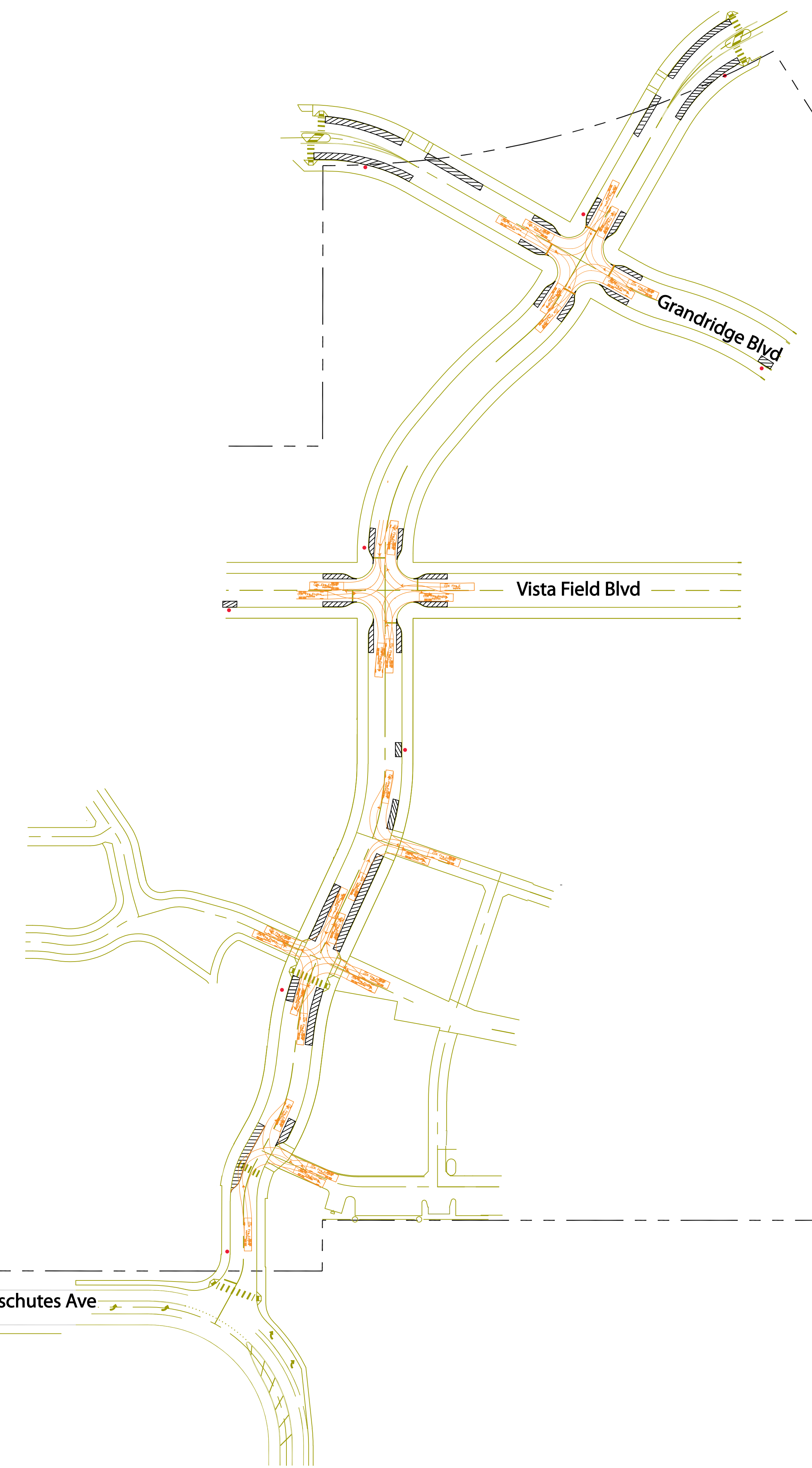

Vista Field No Parking Exhibit Fire Truck Turning Movements

VISTA FIELD REDEVELOPMENT PROJECT - TRANSPORTATION MITIGATION (February 5, 2026)

Cost Allocation Percentages & ROM Cost Estimates

(ALL PARTIES UNDERSTAND - Percentages are the AGREED Factor; Cost Estimates are "PLANNING LEVEL" ONLY)

	2035 Volumes			2035 Operations				Mitigation		Estimated Total Mitigation Cost (\$)	AGREED MITIGATION FACTORS		Currently (2016) TIF Eligible		
	No Build	Build	% Difference	No Build	Build	Mitigation	2035 Operations	Port of Kennewick (%)	Port of Kennewick (\$)						
Phase 1															
6	Columbia Center Boulevard & Grandridge Boulevard														
IMPROVEMENTS COMPLETED 2024 (POK shared Paid)															
10	Colorado Street & Grandridge Boulevard														
	Eastbound	325	527	38.3%	A	8	A	9	-Restrict north-south movements to right-in/right-out only but allow east-west left and right-turns by placing curb along Grandridge Blvd. -Striping/C-curb	A	9	\$65,000	55%	\$35,750	Yes
	Westbound	234	496	52.8%	A	8	A	8		A	8				
	Northbound	216	216	0.0%	E	44	F	>300		B	11				
	Southbound	126	126	0.0%	C	15	E	38		B	13				
23	Edison Street & Canal Drive														
	Eastbound	1143	1328	13.9%	C	34	E	57	-Add a second eastbound left-turn lane -Add a southbound right-turn lane -Signal modification	D	39	\$1,708,000	25%	\$427,000	No
	Westbound	787	834	5.6%	C	25	D	36		D	40				
	Northbound	920	981	6.2%	E	61	E	76		C	34				
	Southbound	1731	1872	7.5%	E	61	E	58		D	45				
New Intersection - Deschutes & Hangar area															
	Eastbound	Intersection was not included as a study area intersection so volumes were not developed.		Intersection was not included as a study area intersection so operations results were not calculated.		-New intersection with all-way stop control and eastbound right-turn bypass lane.						\$780,000	100.0%	\$780,000	No
Note: Movements highlighted in yellow with text in red and bold exceed City LOS thresholds										Subtotal Costs - Teir 1 (TIF Eligible)		\$1,773,000		\$462,750	
										Subtotal Costs - Teir 1 (Non-TIF Eligible)		\$780,000		\$780,000	
										Subtotal Costs - Teir 1 (Total)		\$2,553,000		\$1,242,750	

	2035 Volumes			2035 Operations			Mitigation		Estimated Total Mitigation Cost (\$)	AGREED MITIGATION FACTORS				
	No Build	Build	% Difference	No Build	Build	Mitigation	2035 Operations	Port of Kennewick (%)		Port of Kennewick (\$)	Currently (2016) TIF Eligible			
Phase 2														
4	Columbia Center Boulevard & Quinault Avenue			5124	5669	9.6%	D	47	E	57				
	Eastbound	892	940	5.1%	E	74	E	74	-No mitigation proposed because the overall intersection and each individual approach are forecast to meet City LOS thresholds.		\$1,794,000	0%	\$0	Yes
	Westbound	626	756	17.2%	D	46	E	58						
	Northbound	1693	1872	9.6%	D	40	D	49						
	Southbound	1913	2101	8.9%	D	42	E	57						
7	Columbia Center Boulevard & Deschutes Avenue			4395	4840	9.2%	C	30	D	40				
	Eastbound	526	564	6.7%	C	34	D	49	-Add a second WB left-turn lane -Add a WB right-turn lane		\$1,696,000	25%	\$424,000	Yes
	Westbound	653	853	23.4%	E	69	F	92						
	Northbound	1568	1691	7.3%	C	21	C	20						
	Southbound	1648	1732	4.8%	C	23	C	30						
14	Young Street & Deschutes Avenue			901	1349	33.2%			A	7				
	Eastbound	288	443	35.0%	A	8	A	7	-Install a roundabout		\$650,000	100%	\$650,000	No
	Westbound	376	386	2.6%	na	na	A	6						
	Southbound	237	310	23.5%	C	17	A	10						
	Southwestbound	0	210	100.0%	na	na	A	7						
18	Kellogg Street & Quinault Avenue			1479	1821	18.8%			B	13				
	Eastbound	0	273	100.0%	na	na	C	28	-Install a signal		\$390,000	75%	\$292,500	No
	Westbound	162	303	46.5%	F	87	C	27						
	Northbound	674	643	-4.8%	na	na	A	6						
	Southbound	643	602	-6.8%	A	10	A	6						
19	Kellogg Street & Metaline Avenue			1240	1519	18.4%								
	Eastbound	41	41	0.0%	D	29	F	75	-Install a signal		\$390,000	75%	\$292,500	No
	Westbound	105	199	47.2%	D	26	F	80						
	Northbound	534	572	6.6%	A	9	A	9						
	Southbound	560	707	20.8%	A	9	A	10						
20	Kellogg Street & Deschutes Avenue			1684	2141	21.3%								
	Eastbound	410	529	22.5%	F	52	F	242	-Install a signal		\$1,125,000	75%	\$843,750	No
	Northbound	569	771	26.2%	B	10	B	12						
	Southbound	705	841	16.2%	na	na	na	na						
21	Kellogg Street & Clearwater Avenue			3678	4092	10.1%	C	33	D	44				
	Eastbound	1048	1066	1.7%	B	18	C	29	-Add a second southbound left-turn lane -Signal modification		\$848,000	20%	\$169,600	Yes
	Westbound	1233	1318	6.4%	C	32	D	37						
	Northbound	348	404	13.9%	D	40	E	68						
	Southbound	1049	1304	19.6%	D	46	E	55						
24	Edison Street & Metaline Avenue			1806	2023	10.7%								
	Eastbound	100	223	55.2%	D	26	F	114	-Add a refuge area for left-turns from Edison St.		\$26,000	55%	\$14,300	No
	Northbound	725	772	6.1%	B	11	B	12						
	Southbound	981	1028	4.6%	na	na	na	na						

NOTES

#1) Movements highlighted in yellow with text in red and bold exceed City LOS thresholds;

#2) Mitigation cost share calculations used critical approach volume difference (cells highlighted in bold and blue) as the basis for all intersection except roundabouts which used the overall intersection volume difference. Instances of increased Port share due to impacts identified only in the "Build" scenario and/or when LOS failure in No-Build" scenario involved simple, less expensive solution;

#3) Port Request Intersection indentified with pink hatch be Reclassified as TIF Eligible AND City agreed to consider this request during upcoming TIF update.

#4) Tier 1 and Teir 2 project listed by interesction mitigation priority;

COST ASSUMPTIONS (All costs estimates in 2016 dollars)

- ❖ Right-of-Way acquisition costs are included and assumed at \$20/SF
- ❖ Design costs are included and assumed to be 15% of construction costs
- ❖ Construction costs & construction management (including survey) asumed to be 15% of construction cost
 - ◆ One Lane Roundabout Construction Cost - \$700,000
 - ◆ New Signal Construction Cost - \$600,000
 - ◆ Adding New Approach Lanes Cost - \$500,000
 - ◆ Signal Modification Cost Per Lane - \$150,000

Subtotal Costs - Teir 2 (TIF Eligible)	\$4,338,000	\$593,600
Subtotal Costs - Teir 2 (Non-TIF Eligible)	\$2,581,000	\$2,093,050
Subtotal Costs - Teir 2 (Total)	\$6,919,000	\$2,686,650

TOTAL PROJECT COSTS (TIF Eligible)	\$6,111,000
TOTAL PROJECT COSTS (Non-TIF Eligible)	\$3,361,000
TOTAL PROJECT COSTS	\$9,472,000

\$1,056,350
\$2,873,050
\$3,929,400
PORT Total Mitigation Cost Estimate

2026

FIRE LANE ACCESS EASEMENT

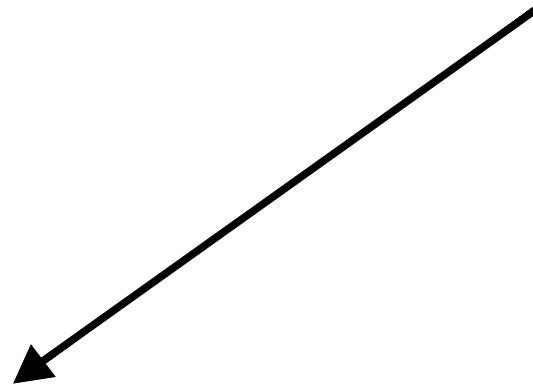

20'-0"

20'-0"

ALLEY (Fire Lane)

10'-0"

10'-0"

ALLEY (Fire Lane)

**Proposed
Requirement**

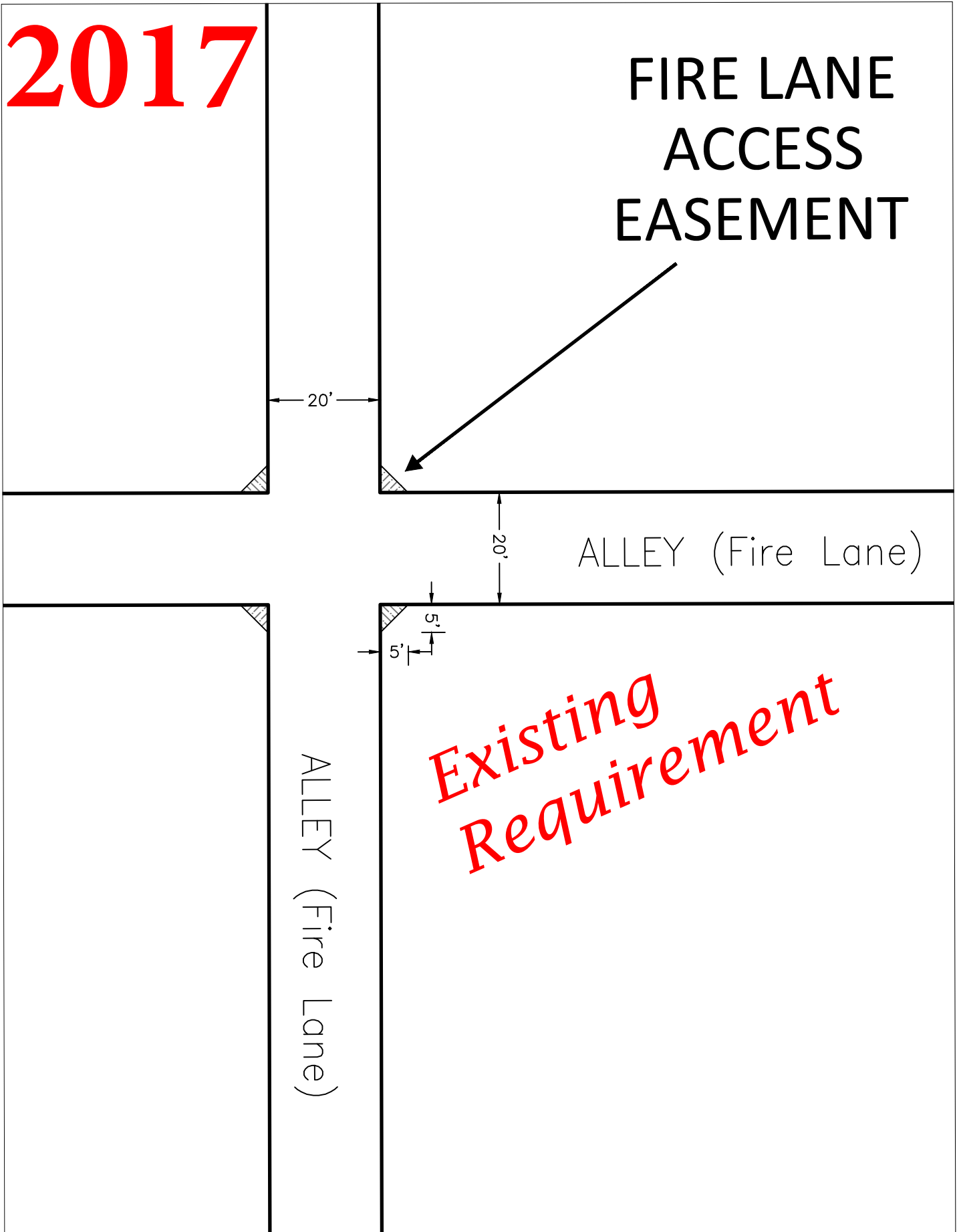

PORT OF KENNEWICK

Resolution No. 2026-06

**A RESOLUTION OF THE PORT OF KENNEWICK
BOARD OF COMMISSIONERS AUTHORIZING AN INTERLOCAL
AGREEMENT WITH THE CITY OF KENNEWICK
REGARDING A JOINT USE PARKING LOT**

WHEREAS, the port and the City of Kennewick (City) have agreed at the staff level on an agreement that would provide for a 400+ space joint use parking lot in the Vista Field area; and

WHEREAS, the parking lot would accommodate users of the City’s entertainment district as well as users of the port’s Vista Field development; and

WHEREAS, by combining resources, the parties can more cost effectively construct needed infrastructure in an area of mutual use; and

WHEREAS, the Commission has been presented with the concept and contractual documents in its Commission Meeting of March 10, 2026;

NOW, THEREFORE, BE IT HEREBY RESOLVED that the Board of Commissioners of the Port of Kennewick hereby authorize the Joint Use Parking Lot Interlocal Agreement with the City of Kennewick.

BE IT FURTHER RESOLVED that the Port of Kennewick Board of Commissioners hereby ratify and approve all action by port officers and employees in furtherance hereof; and authorize the Port Chief Executive Officer to take all action necessary in furtherance hereof.

ADOPTED by the Board of Commissioners of the Port of Kennewick this 24th day of March 2026.

**PORT of KENNEWICK
BOARD of COMMISSIONERS**

By: Excused
Kenneth Hohenberg, *President*

By: DocuSigned by:
Skip Novakovich
0E53A30E1C8E442...
Skip Novakovich, *Vice President*

By: Signed by:
Raul Contreras Gonzalez
5D13B8E79C1A45F...
Raul Contreras Gonzalez, *Secretary*

**INTERLOCAL AGREEMENT
BETWEEN THE
CITY OF KENNEWICK,
KENNEWICK PUBLIC FACILITIES DISTRICT,
AND
PORT OF KENNEWICK**

This Interlocal Agreement (“Interlocal Agreement”) is made and entered into by and between the City of Kennewick, a Washington municipal corporation (“City”); Kennewick Public Facilities District, a Washington municipal corporation (“KPF”); and the Port of Kennewick, a Washington municipal corporation (“Port”). The City, KPF, and Port are individually referred to as a “Party” and collectively referred to as the “Parties.”

WHEREAS, the Interlocal Cooperation Act, Chapter 39.34 Revised Code of Washington (RCW), permits two (2) or more public agencies to enter an agreement for cooperative action; and

WHEREAS, the Three Rivers Convention Center Expansion is designed to attract conventions, meetings, and public events to the City, and support its hotels, restaurants, and shops; and

WHEREAS, the Vista Field Development Project is a multi-use development that will include residential and commercial uses that will provide commercial activity for the entertainment district and the attendees that the Three Rivers Convention Center Expansion will attract; and

WHEREAS, additional parking is required to accommodate said conventions, meetings, commercial activity, and public events; and

WHEREAS, the Parties are authorized to enter an interlocal agreement; and

WHEREAS, the City warrants that the Convention Center and Vista Field projects have been and will be approved with adequate on-site parking to meet the Port and convention center needs, and that any parking on Lot E shall serve as overflow parking in addition to such approved parking; and

WHEREAS, the Parties desire to design and construct a new parking lot on Lot E, Parcel Number 132993BP5289002, located in Kennewick, Benton County, Washington (“Parking Lot E”).

NOW, THEREFORE, in consideration of the foregoing recitals and mutual covenants contained herein, the Parties agree as follows:

1. PURPOSE

This Interlocal Agreement shall establish the administration, specifications, term, contributions, and relationship of the collaboration permitting the Parties to design and construct Parking Lot E to accommodate overflow parking for the Three Rivers Convention Center and Vista Field’s parking demands.

The Parties acknowledge that in addition to the construction of the joint use Parking Lot E, an extension of the Port- City Vista Field Development Agreement is of mutual importance to the Parties. Within 60 days of the effective date of this Interlocal Agreement, the elected bodies of each Party shall consider and take action on the requested ten-year extension of the Development Agreement on terms mutually acceptable to the Parties; provided however, if the Development Agreement is not approved with terms mutually acceptable to the Parties within said 60-day period, the Interlocal Agreement shall automatically terminate and shall be of no force and effect. In such case, the Port shall remain obligated for the costs (1) to KPF for any Port-requested changes to the preliminary design incurred during that 60-day period as set forth in Section 5A, and (2) to the City for fifty percent

(50%) of Parking Lot E's total construction costs incurred during that 60-day period as set forth in Section 5A.

2. ADMINISTRATION

A. KPFD

- i. KPFD prepared preliminary plans, specifications, and estimates for Parking Lot E with the Three Rivers Convention Center Expansion Project. KPFD shall provide the Parties with a copy of the current budget as a condition of approval of this Interlocal Agreement.
- ii. The Parties shall meet and determine whether changes to KPFD's preliminary plans are necessary to accommodate the Port. The Parties anticipate the Port will request certain changes to KPFD's preliminary plans to include additional access points as depicted in the "Conceptual Port Proposed Design Changes" which is attached hereto and incorporated herein as Exhibit "A". The Parties will receive any resulting, revised preliminary plans and have not less than ten (10) days to review, comment and approve.
- iii. KPFD shall request and receive the City and Port's written approval of the final plans, specifications, and estimates before finalizing bids and the construction timeline.
- iv. The construction of Parking Lot E will be completed under the Three Rivers Convention Center Expansion construction agreement executed with KPFD and LYDIG Construction.

B. Contents

This Interlocal Agreement consists of this Interlocal Agreement, and Exhibit A ("Conceptual Port Proposed Design Changes") and Exhibit B ("Reciprocal Parking License Agreement"), which are attached hereto and incorporated herein by reference.

The Parties agree that these documents form the entire Interlocal Agreement; no oral or written agreements, representations, or understandings exist outside of this Interlocal Agreement; and any and all prior agreements, representations, or understandings are terminated upon execution of this Interlocal Agreement. If a conflict regarding this Interlocal Agreement arises, the Parties agree that the order of precedence is (i) this Interlocal Agreement; (ii) Exhibit B; and (iii) properly acknowledged, executed, signed, and recorded amendments, change orders, and modifications from the Parties in that order.

3. SPECIFICATIONS

Parking Lot E shall be constructed to commercial standards and shall be comprised of:

- A. asphalt concrete surfacing and stormwater improvements;
- B. concrete curbs, ramps, driveways, gutters, and sidewalks;
- C. signs and surface markings;
- D. light fixtures;
- E. Electric vehicle (EV) charging stations;
- F. Access points as determined by the Parties and permitted by applicable development regulations,
- G. Roosevelt Street improvements abutting SW parcel line Lot E.

4. TERM

This Interlocal Agreement shall commence on the date of the last signature execution hereon and remain in effect until Parking Lot E is completed and accepted by the City, KPF, and Port and all Parties have paid their portion of the project, or the Interlocal Agreement is terminated by any Party.

5. COSTS

A. Design

The Port shall pay KPF one hundred percent (100%) of the cost of any Port requested changes to the preliminary design for Parking Lot E, KPF shall directly bill the Port for this cost.

B. Construction

The Port shall pay the City fifty percent (50%) of Parking Lot E's total construction costs, including costs arising from properly acknowledged, executed, signed, and recorded change orders, not to exceed one million dollars (\$1,000,000) in total. Construction costs are defined as LYDIG Construction invoices specific to the Parking Lot E work.

C. Change Orders

If a proposed change order exceeds ten percent (10%) of the total project cost, KPF shall request and receive the City and Port's written approval before approving the change order.

If KPF does not receive the City and/or Port's approval within seven (7) days, the Parties agree to meet within fourteen (14) days to acquire additional funds, modify Parking Lot E's scope, or terminate this Interlocal Agreement.

D. Invoices

KPF shall provide the City and Port with all invoices for work completed or services rendered in writing and send them to the representatives and addresses provided below. KPF shall direct its contractor LYDIG Construction to issue invoices specific to the Parking Lot E work and not comingle with invoices and charges related to the Three Rivers Convention Center Expansion construction.

City of Kennewick
Attn: Erin Erdman, City Manager
P.O. Box 6108
Kennewick, WA 99336
(509) 585-4251
erin.erdman@ci.kennewick.wa.us

Port of Kennewick
Attn: Tim Arntzen, Chief Executive Officer
350 Clover Island Dr., Ste. 200
Kennewick, WA 99336
(509) 586-1186
ta@portofkennewick.org

E. Payments

The Port shall pay the City for work performed or services rendered after receiving detailed invoices and send payments to the representative and address provided below:

City of Kennewick
Attn: Jessica Platt, Finance Director
P.O. Box 6108
Kennewick, WA 99336
(509) 585-4552
jessica.platt@ci.kennewick.wa.us

Invoices not in dispute by the City or Port shall be paid net thirty (30) days and shall reference this Interlocal Agreement's number. The invoices shall provide sufficient detail on the work billed. The Port's final payment for its 50% share of the total cost of construction shall be paid no later than January 31, 2027, provided construction is substantially complete at that time.

6. **RELATIONSHIP**

This Interlocal Agreement shall not create a new or separate administrative or legal entity for the administration or interpretation of this Interlocal Agreement's terms, conditions, or provisions.

7. **PARTIES' RESPONSIBILITIES**

- A. Each Party hereby agrees to collaborate with the other Parties in the design, construction, and funding of Parking Lot E.
- B. Each Party shall be responsible for complying with all applicable statutes, rules, policies, and procedures; provided however, the Port's responsibility is strictly limited to payment as described herein and does not extend to construction oversight or public works construction or repair reporting, payment, or compliance, and or any claims related to the condition of the site
- C. The Port shall be responsible for allocating the funds to pay the KPFD one hundred percent (100%) of the cost of any Port requested changes to the preliminary design for Parking Lot E and the City fifty percent (50%) of Parking Lot E's total construction costs, including costs arising from properly acknowledged, executed, signed, and recorded change orders, and not to exceed one million dollars (\$1,000,000) in total.

8. **COMMUNICATION**

The Parties shall produce all communications regarding this Interlocal Agreement in writing and send them to the representatives and addresses provided below:

City of Kennewick
Attn: Erin Erdman, City Manager
P.O. Box 6108
Kennewick, WA 99336
(509) 585-4251
erin.erdman@ci.kennewick.wa.us

Kennewick Public Facilities District
Attn: Calvin Dudney, President
7016 W. Grandridge Blvd.
Kennewick, WA 99336
(509) 948-5593
cdudney@3riverscampus.com

Port of Kennewick
Attn: Tim Arntzen, Chief Executive Officer
350 Clover Island Dr., Ste. 200
Kennewick, WA 99336
(509) 586-1186
ta@portofkennewick.org

9. AMENDMENT

The Parties may mutually amend this Interlocal Agreement, or any section or subsection thereof, in a properly acknowledged, executed, signed, and recorded writing from all Parties.

10. ASSIGNMENT

All of the terms, conditions, and provisions hereof shall inure to the benefit of, and be binding upon, the Parties, their respective successors, and their respective assigns. However, a Party shall not assign any right or obligation under this Interlocal Agreement to a third party without a properly acknowledged, executed, signed, and recorded writing from the other Parties.

11. TERMINATION

- A. A Party may unilaterally terminate this Interlocal Agreement upon thirty (30) days' written notice before Parking Lot E's construction starts. Should the Port decide to terminate the Interlocal Agreement prior to construction they will be responsible for the costs incurred prior to and through termination for any Port-requested conceptual design changes, with the exception of access and frontage improvements to Roosevelt Street.
- B. The Parties may mutually terminate this Interlocal Agreement after Parking Lot E's construction starts in a properly acknowledged, executed, signed, and recorded writing from all Parties.
- C. If this Interlocal Agreement is terminated by mutual agreement after construction begins, the Port shall pay KPFDD the costs of any Port-requested changes to the preliminary design for Parking Lot E incurred before the termination date pursuant to Section 5, Subsection A of this Interlocal Agreement. The Port shall also pay the City fifty percent (50%) of Parking Lot E's total construction costs incurred before the termination date, including costs arising from properly acknowledged, executed, signed, and recorded change orders pursuant to Section 5, Subsection B of this Interlocal Agreement.
- D. Notwithstanding anything to the contrary herein, the City shall not terminate the Port's License as long as Parking Lot E remains a surface parking lot. The Master Plan for the Entertainment Districts shows Lot E to remain parking, however a larger project, such as the reconstruction of the Toyota Center would require Lot E to be converted to Structured Parking which would then allow for termination of this agreement.

12. DOCUMENT OWNERSHIP

All designs, drawings, specifications, documents, reports and other work products prepared pursuant to this Interlocal Agreement, shall become City, KPF, and Port property upon completion of construction and payment in full of all payments due.

13. GENERAL REQUIREMENTS

A. Meetings

The City and Port shall attend status, progress, and coordination meetings with the designated KPF and Contractor representative(s). If the City or Port requests KPF or Contractor participation at additional meetings, the City or Port shall provide KPF and the Contractor with notice prior to those meetings.

B. Progress Reports

If the City or Port requests progress reports, KPF shall provide both with detailed reports outlining in written and/or graphical form the phases and work performed.

14. INDEMNIFICATION

A. City's Indemnification and Hold Harmless

The City shall defend, indemnify, and hold KPF and the Port, its officers, officials, employees, volunteers, and agents harmless from any and all claims, injuries, damages, losses, or suits, including attorneys' fees, arising out of or resulting from the negligent acts, errors, or omissions of the City, its officers, contractors, officials, employees, volunteers, and agents ("City Agents"), excluding injuries and damages caused by the sole negligence of KPF, KPF Agents, Port Agents, or the Port.

B. KPF's Indemnification and Hold Harmless

KPF shall defend, indemnify, and hold the City and Port, its officers, officials, employees, volunteers, and agents harmless from any and all claims, injuries, damages, losses, or suits, including attorneys' fees, arising out of or resulting from the negligent acts, errors, or omissions of KPF, its officers, officials, employees, volunteers, and agents, ("KPF Agents"), excluding injuries and damages caused by the sole negligence of the City, City Agents, Port Agents or Port.

C. Port's Indemnification and Hold Harmless

The Port shall defend, indemnify, and hold the City and KPF, its officers, officials, employees, volunteers, and agents harmless from any and all claims, injuries, damages, losses, or suits, including attorneys' fees, arising out of or resulting from the negligent acts, errors, or omissions of the Port, its officers, officials, employees, volunteers, and agents, excluding injuries and damages caused by the sole negligence of the City, City Agents, KPF Agents, or KPF.

15. ADVERSE CHANGE IN LAW

If a federal, state, or local statute, rule, regulation, ordinance, or court decision renders performance of the work impossible, impractical, or illegal or materially and adversely affects the ability of any Party to fulfill the obligations or receive the benefits of this Interlocal Agreement (collectively referred to as an "Adverse Change in Law"), the Parties agree to meet within fourteen (14) days following written notice of an Adverse Change in Law to negotiate an amendment in good faith which carries out the Parties' original intent. If the Parties do not reach an agreement within sixty (60) days after commencement of the negotiation despite their good faith efforts, any Party may terminate this

Interlocal Agreement on the earlier of the effective date of the Adverse Change in Law or expiration of the sixty (60)-day period following written notice of termination provided by one Party to the others.

16. DISPUTE RESOLUTION

A. Good Faith

The Parties agree to negotiate in good faith for a period of thirty (30) days from the date of notice of all disputes between them prior to exercising their rights under this Interlocal Agreement or under law.

B. Arbitration

All unresolved disputes between the Parties may only be arbitrated by mutual agreement of the Parties. If a mutual agreement is not reached, the claim shall be resolved by legal action.

C. Venue, Law, and Jurisdiction

If one or more Party(ies) initiate(s) legal action to enforce any right or obligation under this Interlocal Agreement, the Parties agree that such action shall be initiated in Benton County Superior Court, located in Kennewick, Benton County, Washington. The Parties also agree that all questions shall be resolved by application of Washington law and the Parties to such action shall have the right to appeal Benton County Superior Court's decision in accordance with Washington law. The Parties hereby consent to the personal jurisdiction of Benton County Superior Court.

D. Attorneys' Fees

If one or more Party(ies) initiate(s) legal action to enforce any right or obligation under this Interlocal Agreement, the Parties agree that the prevailing Party(ies) shall be awarded its (their) reasonable attorneys' fees, including appeal costs and fees.

17. SEVERABILITY

If any court of competent jurisdiction renders any of the terms, rights, obligations, or conditions contained in this Interlocal Agreement unenforceable or sections, subsections, provisions, paragraphs, sentences, or phrases invalid, it shall not affect the enforceability of the remaining terms, rights, obligations, or conditions or validity of the remaining sections, subsections, provisions, paragraphs, sentences, or phrases contained therein.

18. SURVIVABILITY

If the Parties amend or terminate this Interlocal Agreement, it shall not affect the survivability of any of the terms, rights, obligations, or conditions contained in this Interlocal Agreement or exercise of any of the rights associated therewith.

19. WAIVER

Any Party's failure to request strict performance of this Interlocal Agreement, or any section or subsection thereof, or failure to exercise any right associated therewith, shall not constitute a waiver of any right.

20. PUBLIC DISCLOSURE

The Parties recognize that the City and Port are governed by the Public Records Act, Chapter 42.56 RCW, which requires the City and Port to offer the public maximum assistance, including timely access

to records unless those records are exempt or potentially exempt. This Interlocal Agreement is a public record and will be released upon request.

21. FILING

As provided by RCW 39.34.040, prior to its entry in force this Interlocal Agreement must be recorded with the Benton County Auditor and/or posted on each Parties' website.

22. NO PUBLIC DUTY, THIRD PARTY BENEFICIARIES, PARTNERSHIPS

No undertaking by one Party to, the other Party under any provision of this Interlocal Agreement shall create any special duty to the public or otherwise enhance or modify the obligation of the Party with regard to the public or any person.

Nothing in this Interlocal Agreement shall be construed to create any rights in or duties to any third party, nor any liability to or standard of care with reference to any third party. This Interlocal Agreement shall not confer any right, or remedy upon any person other than the Parties. This Interlocal Agreement shall not release or discharge any obligation or liability of any third party to any Party.

23. RECORDS RETENTION AND AUDIT

The Parties agree to maintain records of all costs incurred under this ILA in accordance with a work order accounting system as prescribed and approved by the State Auditor's Office. These records will be kept available for inspection and audit by the Party requesting the service for six years after payment of the requested service.

24. COUNTERPARTS

This Interlocal Agreement may be executed in two (2) or more counterparts, each of which shall be deemed an original, but all of which shall constitute one (1) and the same instrument. This Interlocal Agreement may be delivered by electronic mail or other means and those signatures shall be treated as original signatures for all applicable purposes. The persons signing this Interlocal Agreement represent that they are authorized to sign on behalf of their respective Parties and bind them.

IN WITNESS WHEREOF, the Parties hereto enter this Interlocal Agreement on the date of the last signature execution hereon.

CITY OF KENNEWICK

Jason R. McShane
Mayor

Date

Attest:

Krystal Johnston
City Clerk

Date

Approved as to form:

Laurencio Sanguino
City Attorney

Date

KENNEWICK PUBLIC FACILITIES DISTRICT

Calvin Dudney
President

Date

Attest:

Megan Caldwell
Ex-Officio Clerk

Date

Approved as to form:

Heidi Ellerd
Attorney

Date

PORT OF KENNEWICK

Tim Arntzen CEO

Date

Approved as to form:

Carolyn Lake
Port Attorney

Date

EXHIBIT A

Conceptual Port Proposed Design Changes

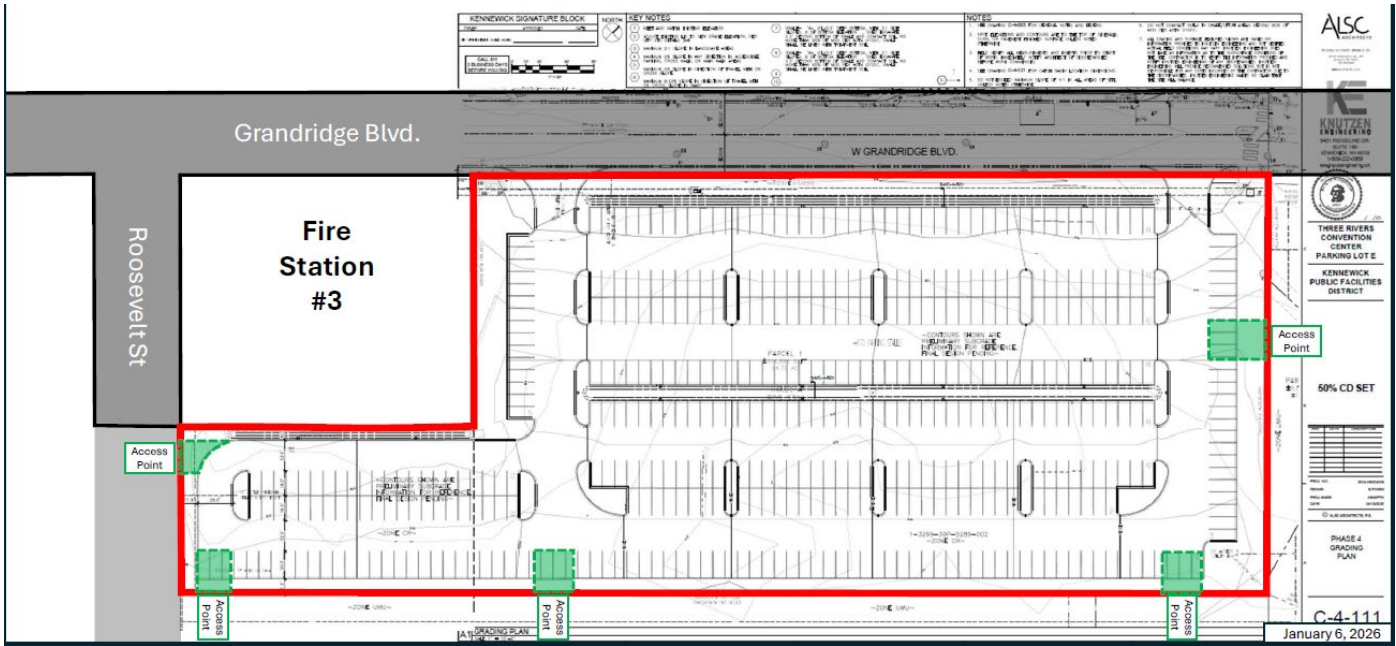

This graphic depicts the conceptual design changes from the Port of Kennewick for Parking Lot E. These will be subject to further discussion and review and must be compliant with all applicable development regulations.

Exhibit "B"
RECIPROCAL PARKING LICENSE AGREEMENT
BETWEEN THE
CITY OF KENNEWICK,
KENNEWICK PUBLIC FACILITIES DISTRICT,
AND
PORT OF KENNEWICK

This Reciprocal Parking License Agreement ("License Agreement") is made and entered into by and between the City of Kennewick, a Washington municipal corporation ("City" and "Licensor"); Kennewick Public Facilities District, a Washington municipal corporation ("KPF" and "Licensor"); and the Port of Kennewick, a Washington municipal corporation ("Port" and "Licensee"). The City, KPF, and Port are individually referred to as a "Party" and collectively referred to as the "Parties."

WHEREAS, the City is the owner of the Three Rivers Convention Center and adjacent parking, which is subject to a long-term lease with KPF; and

WHEREAS, the Parties desire to design and construct a new parking lot on Lot E, Parcel Number 132993BP5289002, located in Kennewick, Benton County, Washington ("Parking Lot E"); and

WHEREAS, the Licensee desires to use the Licensors' parking; and

WHEREAS, there is sufficient parking on the property owned and managed by the Licensors to accommodate on-site parking and meet the Licensee's needs; and

WHEREAS, the Licensors desire to meet the Licensee's parking needs by granting this License Agreement;

NOW, THEREFORE, in consideration of the foregoing recitals and mutual covenants contained herein, the Parties agree as follows:

1. LICENSE

The Licensors hereby grant a perpetual, non-exclusive license for vehicle ingress, egress, and parking on Parking Lot E to the Licensee ("License").

2. NON-EXCLUSIVE VARIABLE JOINT-USE

The License is a non-exclusive variable joint-use license for the right of ingress and egress over and across, together with parking rights upon the portions designated thereon, for all the Licensee's guests, patrons, invitees, employees, and agents for such period as the Licensors own and manage the Three Rivers Convention Center and Parking Lot E unless the City unilaterally terminates the License pursuant to Section 11 of this License Agreement.

3. ACCESS

Parking Lot E shall be lined and include traffic direction, curbing, landscaping, and driveways. No fences, barriers, or obstacles shall be placed by the Licensee upon Parking Lot E that prohibit access to or from the Licensors' adjacent parking, driveways, or public streets. If an event at the Three Rivers Convention Center uses Parking Lot E for displays, tents, or other activities, KPF shall provide the Licensee with written notice and adequate parking.

4. TERM

This License shall commence on the date of the last signature execution hereon and remain in effect until it is terminated by any Party.

5. COSTS

A. Maintenance

The Licensors shall maintain Parking Lot E. Such maintenance shall include cleaning, striping, landscaping, irrigation, and snow and ice removal. Parking Lot E shall be maintained as clean and attractive as the Licensors' adjacent parking.

B. Repairs

The Licensors shall repair, replace, or repaint damaged:

- i. asphalt concrete surfacing;
- ii. concrete curbs, ramps, driveways, gutters, and sidewalks;
- iii. signs and surface markings;
- iv. light fixtures;
- v. landscaping; and
- vi. irrigation.

The Licensee shall pay the Licensors fifty percent (50%) of Parking Lot E's total repair costs.

C. Invoices

The Licensors shall provide the Licensee with all repair invoices in writing and send them to the representative and address provided below:

Port of Kennewick
Attn: Nick Kooiker, Chief Financial Officer
350 Clover Island Dr., Ste. 200
Kennewick, WA 99336
509-586-1186 nick@portofkennewick.org

D. Payments

The Licensee shall pay the Licensors for repairs performed after receipt of detailed invoices and send payments to the representative and address provided below:

Three Rivers Convention Center
Attn: Joe Potts
7016 W Grandridge Blvd
Kennewick, WA 99336
(509) 737-3725
jpotts@3riverscampus.com

Invoices not in dispute by the Licensee shall be paid net thirty (30) days.

6. PERMITTED USERS/RIGHT TO USE

The ingress, egress, and parking License granted herein may be used by the Licensors and Licensee's guests, patrons, invitees, employees, and agents simultaneously. Each Party shall have equal rights for such access and parking on Parking Lot E and shall take no action to prevent another Party's enjoyment of such rights. The parking spaces shall not be allocated to site specific uses by either party and shall remain subject to joint use by each party.

7. COVENANTS RUN WITH THE LAND

All the terms and conditions of this License Agreement, including the benefits and burdens, shall attach to and run with the land and shall be binding upon, inure to the benefit of, and be enforceable by the Licensors and Licensee and their successors and assigns.

8. LIMITED AND NON-USE

Limited and non-use of the License shall not prevent the Licensee or its successors and assigns' future use of Parking Lot E to the fullest extent authorized by this License Agreement.

9. AMENDMENT

- A. The Parties may mutually amend this License Agreement, or any section or subsection thereof, in a properly acknowledged, executed, and signed writing from the Parties recorded with the Benton County Auditor.
- B. If a parking garage is constructed on or adjacent to Parking Lot E, the City may unilaterally amend this License Agreement, or any section or subsection thereof, in a properly acknowledged, executed, and signed writing from the City recorded with the Benton County Auditor.

10. ASSIGNMENT

All of the terms, conditions, and provisions hereof shall inure to the benefit of, and be binding upon, the Parties, their respective successors, and their respective assigns. However, a Party shall not assign any right or obligation under this License Agreement to a third party without a properly acknowledged, executed, signed, and recorded writing from the other Parties.

11. TERMINATION

- A. A Party may unilaterally terminate this License Agreement upon thirty (30) days' written notice in a properly acknowledged, executed, and signed writing from the Parties recorded with the Benton County Auditor.
- B. The Parties may mutually terminate this License Agreement in a properly acknowledged, executed, signed, and recorded writing from the Parties recorded with the Benton County Auditor.
- C. If a parking garage is constructed on or adjacent to Parking Lot E, the City may unilaterally terminate this License Agreement upon thirty (30) days' written notice in a properly acknowledged, executed, and signed writing from the City recorded with the Benton County Auditor.
- E. If this License Agreement is terminated, the Licensee shall pay the Licensors fifty percent (50%) of Parking Lot E's total repair costs incurred before the termination date pursuant to Section 5, Subsection B of this License Agreement.

12. INDEMNIFICATION

The Licensee shall defend, indemnify, and hold the Licensors, their officers, officials, employees, volunteers, and agents harmless from any and all claims, injuries, damages, losses, or suits, including attorneys' fees, arising out of or resulting from the Licensee's guests, patrons, invitees, employees, or agents' use of Parking Lot E, excluding injuries and damages caused by the sole negligence of the Licensors.

13. DISPUTE RESOLUTION

A. Good Faith

The Parties agree to negotiate in good faith for a period of thirty (30) days from the date of notice of all disputes between them prior to exercising their rights under this License Agreement or under law.

B. Arbitration

All unresolved disputes between the Parties may only be arbitrated by mutual agreement of the Parties. If a mutual agreement is not reached, the claim shall be resolved by legal action.

C. Venue, Law, and Jurisdiction

If one or more Party(ies) initiate(s) legal action to enforce any right or obligation under this License Agreement, the Parties agree that such action shall be initiated in Benton County Superior Court, located in Kennewick, Benton County, Washington. The Parties also agree that all questions shall be resolved by application of Washington law and the Parties to such action shall have the right to appeal Benton County Superior Court's decision in accordance with Washington law. The Parties hereby consent to the personal jurisdiction of Benton County Superior Court.

D. Attorneys' Fees

If one or more Party(ies) initiate(s) legal action to enforce any right or obligation under this License Agreement, the Parties agree that the prevailing Party(ies) shall be awarded its (their) reasonable attorneys' fees, including appeal costs and fees.

14. SEVERABILITY

If any court of competent jurisdiction renders any of the terms, rights, obligations, or conditions contained in this License Agreement unenforceable or sections, subsections, provisions, paragraphs, sentences, or phrases invalid, it shall not affect the enforceability of the remaining terms, rights, obligations, or conditions or validity of the remaining sections, subsections, provisions, paragraphs, sentences, or phrases contained therein.

15. SURVIVABILITY

If the Parties amend or terminate this License Agreement, it shall not affect the survivability of any of the terms, rights, obligations, or conditions contained in this License Agreement or exercise of any of the rights associated therewith.

16. WAIVER

Any Party's failure to request strict performance of this License Agreement, or any section or subsection thereof, or failure to exercise any right associated therewith, shall not constitute a waiver of any right.

17. PUBLIC DISCLOSURE

The Parties recognize that the City is governed by the Public Records Act, Chapter 42.56 Revised Code of Washington (RCW), which requires the City to offer the public maximum assistance, including timely access to records unless those records are exempt or potentially exempt. This License Agreement is a public record and will be released upon request.

18. FILING

As provided by RCW 39.34.040, prior to its entry in force this Interlocal Agreement must be recorded with the Benton County Auditor and/or posted on each Parties' website.

19. NO PUBLIC DUTY, THIRD PARTY BENEFICIARIES, PARTNERSHIPS

No undertaking by one Party to, the other Party under any provision of this Interlocal Agreement shall create any special duty to the public or otherwise enhance or modify the obligation of the Party with regard to the public or any person.

Nothing in this Interlocal Agreement shall be construed to create any rights in or duties to any third party, nor any liability to or standard of care with reference to any third party. This Interlocal Agreement shall not confer any right, or remedy upon any person other than the Parties. This Interlocal Agreement shall not release or discharge any obligation or liability of any third party to any Party.

20. RECORDS RETENTION AND AUDIT

The Parties agree to maintain records of all costs incurred under this ILA in accordance with a work order accounting system as prescribed and approved by the State Auditor's Office. These records will be kept available for inspection and audit by the Party requesting the service for six years after payment of the requested service.

[Signature Pages Follow]

This License Agreement may be executed in two (2) or more counterparts, each of which shall be deemed an original, but all of which shall constitute one (1) and the same instrument. This License Agreement may be delivered by electronic mail or other means and those signatures shall be treated as original signatures for all applicable purposes. The persons signing this License Agreement represent that they are authorized to sign on behalf of their respective Parties and bind them.

IN WITNESS WHEREOF, the Parties hereto enter this License Agreement on the date of the last signature execution hereon.

CITY OF KENNEWICK

Jason R. McShane
Mayor

Date

Attest:

Krystal Johnston
City Clerk

Date

Approved as to form:

Laurencio Sanguino
City Attorney

Date

KENNEWICK PUBLIC FACILITIES DISTRICT

Calvin Dudney
President

Date

Attest:

Megan Caldwell
Ex-Officio Clerk

Date

Approved as to form:

Heidi Ellerd
Attorney

Date

PORT OF KENNEWICK

Tim Arntzen
Port CEO

Date

Attest:

Bridgette Scott
Executive Assistant

Date

Approved as to form:

Carolyn Lake
Port Attorney

Date

Jerome Delvin, District 1
Michael Alvarez, District 2
Will McKay, District 3



Jerrod MacPherson
County Administrator
Matt Rasmussen
Deputy County Administrator

Board of County Commissioners

March 24, 2026

Port of Kennewick
350 Clover Island Drive – Suite 200
Kennewick, Washington 99336

Congratulations – Tana Bader Inglima

Dear Port of Kennewick Commissioners, Staff, and most of all Tana:

Benton County does a lot of work with many different partners in this community and beyond. One of our best working relationships is with the Port of Kennewick. Thanks to your commission and staff of efficiency, responsiveness, and overall good practices that makes the Port easy to work with and effective. A big contributor to this reputation and reality has been Tana Bader Inglima. Tana has been our main point of contact at the Port for nearly two decades, and this has made it easy and enjoyable for us to do work with the Port. We are excited for Tana as she embarks on her life’s next journey as we look forward to our continued work on many great projects with the Port of Kennewick team. Thank you for being a consistently great partner.

Tana, we are very happy for you to reach this milestone and we wish you all the best in your retirement. Congratulations, safe travels, and good health to you. You’ve earned it!

Sincerely,

BOARD OF COUNTY COMMISSIONERS

Michael Alvarez, Chairman

Will McKay, Chairman Pro-Tem

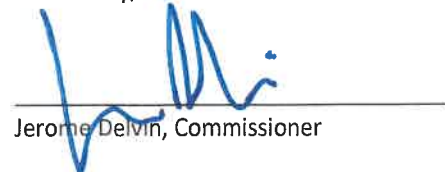
Jerome Delvin, Commissioner

Governmental Relations

Internal Communications / External Communications

Commission Support / Marketing & Advertising

Media Relations / Community Relations

Brand Management / “Purple Clipboard” Event Management

Friend Building / Fundraising / etc....



WEST RICHLAND
CHAMBER OF COMMERCE



EXHIBIT B



PORT *of*
KENNEWICK

Columbia Gardens

Port of Kennewick turns industrial zone into wine and food destination



Exciting Happenings at Vista Field Welcoming the First Businesses

Port of Kennewick has been working to transform the 103-acre Vista Field site into a regional town center. Located in the heart of the Tri-Cities community – adjacent the Three Rivers Convention Center and Toyota Center – Vista Field has been intentionally designed to create a live-work, mixed-use development filled with inspirational gathering spaces, a linear park with fountains and pedestrian bridges.

Phase one opened 20 acres to development with eight parcels already sold or committed for retail and residential. And now, Vista Field has reached another major milestone, and the community-driven master plan is taking shape.

Two private-sector buildings have been constructed, and other developments are in the works. Read more inside this newsletter for the latest about Blueberry Bridal and Kuki Izakaya, the first businesses greeting the public at Vista Field.

Article continues inside

SPRING 2026

PORT of KENNEWICK



Columbia Gardens Artisan Village

EXHIBIT B

Shovel-Ready Parcels for Sale

227 E. Columbia Gardens Way 309

320 E. Columbia Gardens Way (this parcel can be subdivided)

Cedar Street

E. Columbia Drive

Date Street

WINE & FOOD

BRENDI DAVYON ART

FOOD TRUCK PLAZA Columbia Gardens

MONARCHA

BARTHOLOMEW WINE

Work growth and locate a production/ tasting room, restaurant or retail business at Columbia Gardens Artisan Village.

Port of Kennewick is proud to...

Work Plan Summary

PLANNED WORK HIGHLIGHTS

2025 - 2026

Kuki Izakaya restaurant owner, Isakaya Ken and her family (center) with officials from Port of Kennewick, Pacific County, City of Kennewick and government officials on June 29, 2024, groundbreaking ceremony.



KUKI IZAKAYA RESTAURANT
ARTIST'S RENDERING



BLUEBERRY BRIDAL SHOP
ARTIST'S RENDERING



COLUMBIA POINT EYE CARE CLINIC
ARTIST'S RENDERING



VATIK DULO & RYAN FOSTER DEVELOPMENT
ARTIST'S RENDERING

Planned Vista Field Private Sector Investment

Tri-City Herald

EXHIBIT B



Media Partners

PORT *of*
KENNEWICK



Shaping the Future of Vista Field

Public Input Wanted

Vista Field redevelopment is a once-in-a-lifetime opportunity. The acre site is owned by the Port of Kennewick on behalf of the citizens. Stakeholders have indicated a desire for plazas and water features (development site example photos are below); and support for a pay-as-you-go approach--looking to leverage the port's land with private equity from developers, builders or investors to create a special, family-oriented pedestrian-friendly, centrally-located living, working, and gathering place for the region. Public meetings are scheduled and community involvement is encouraged.

Meeting schedule posted at: www.PortOfKennewick.org/airport.
Share comments at: VistaField@PortOfKennewick.org.

PORT OF KENNEWICK

HISTORIC WATERFRONT DISTRICT

MASTER PLAN

JUNE 22, 2021



CONFEDERATED TRIBES
of the
Umatilla Indian Reservation

P.O. BOX 638
PENDLETON, OREGON 97801
Area Code 541 Phone: 278-3165 Fax: 278-3095

GENERAL COUNCIL
and
BOARD OF TRUSTEES

December 15, 2008

David Hanson, president
Board of Commissioners
Port of Kennewick
350 Clover Island Drive, Suite 200
Kennewick, WA 99336

Dear Mr. Hanson:

On behalf of the Confederated Tribes of the Umatilla Indian Reservation (CTUIR), I would like to express our support for the Port of Kennewick's Clover Island Shoreline Improvement and Urban Renewal project. We feel this project is important to the local community through job growth and economic diversification as well as enhancing the quality of life regionally.

One of the intended results of this project is to...





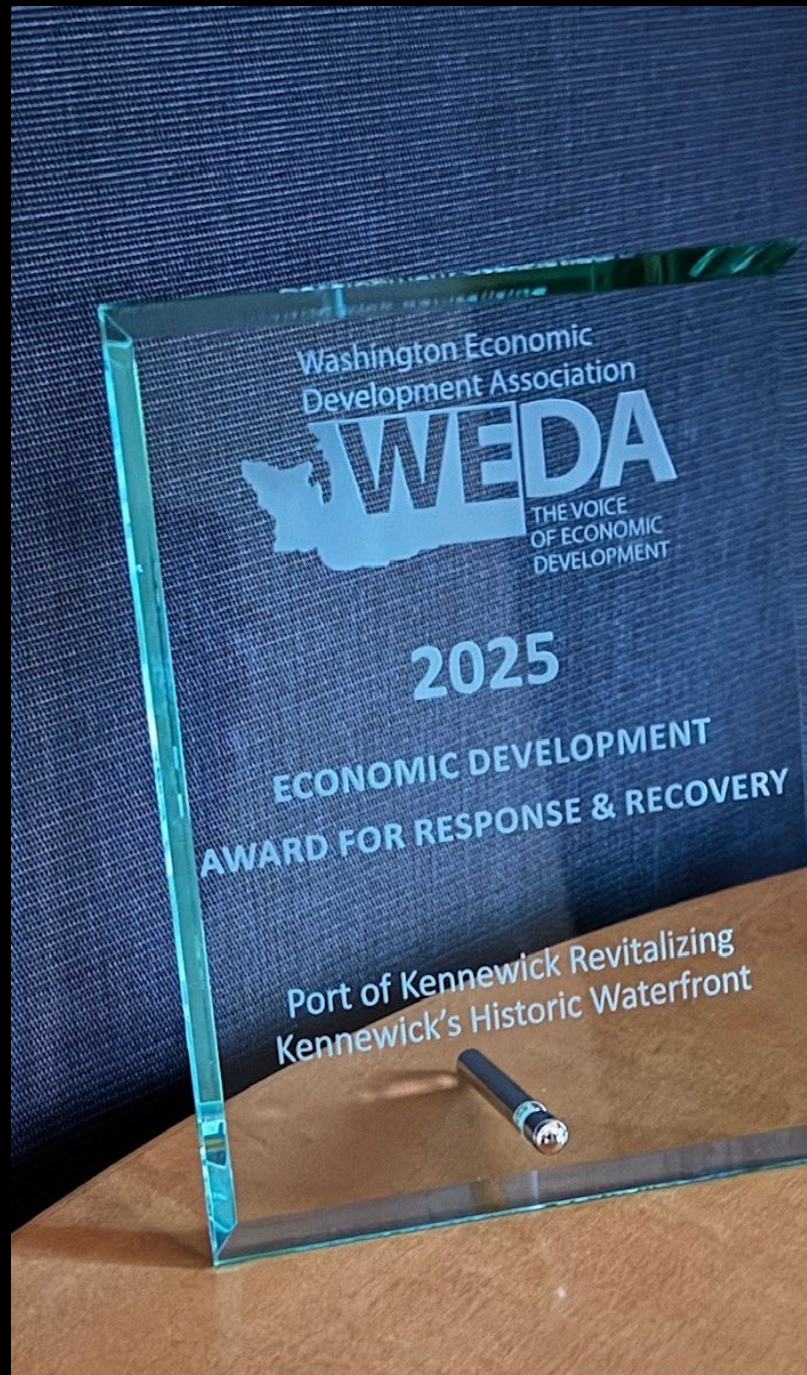

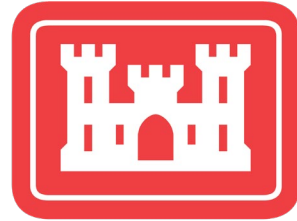

**US Army Corps
of Engineers®**

Walla Walla District



HANFORD AREA ECONOMIC INVESTMENT FUND



WASHINGTON STATE
Recreation and
Conservation Office



Grant Partners

PORT *of*
KENNEWICK



Thank You!

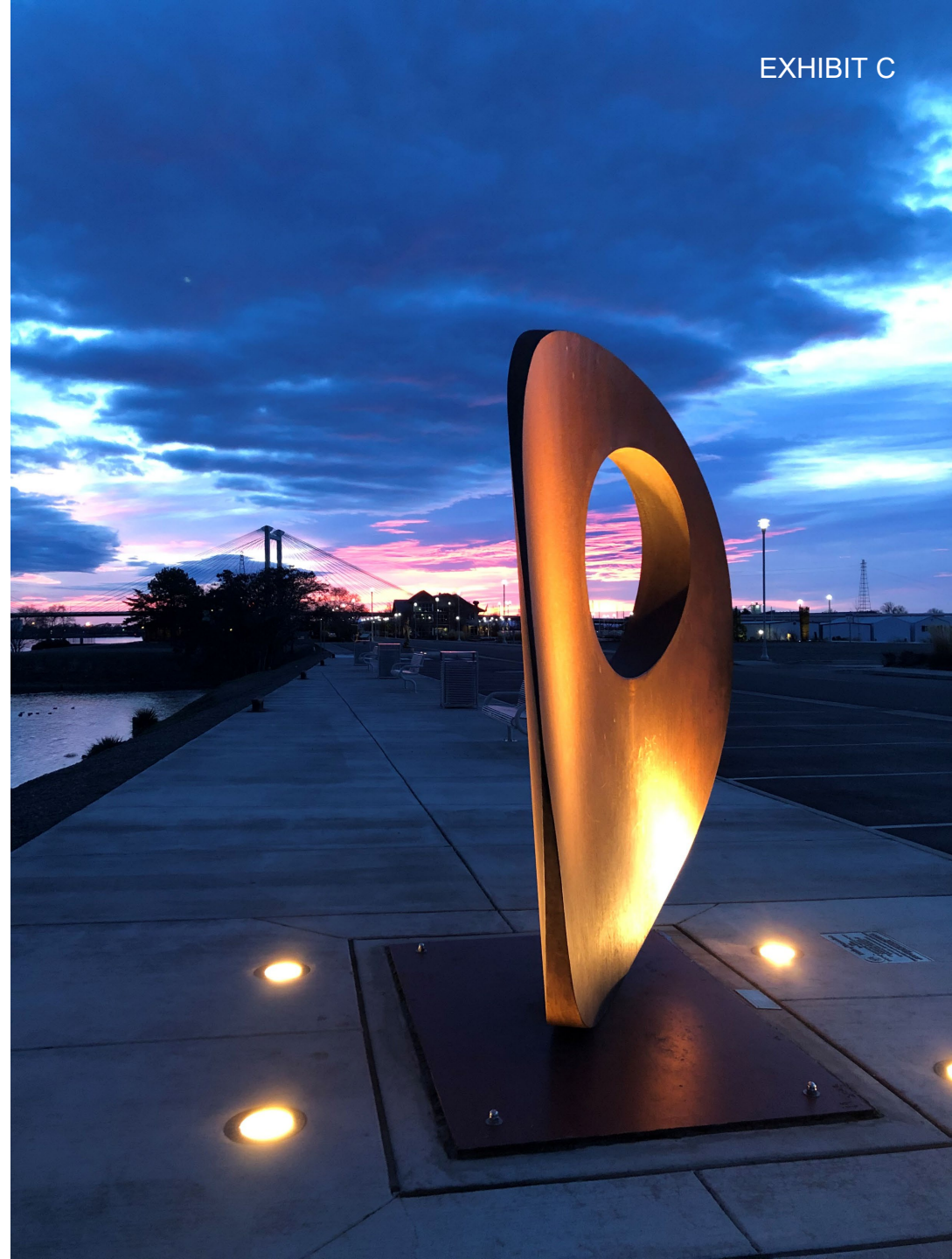





EXHIBIT C













INTRODUCTION AND PURPOSE

Part 1.0

1.3 Port Managing Official. The Commission has delegated to the CEO such administrative powers as deemed proper for the efficient management of operations.

COMMISSION AND COMMISSIONERS

Part 2.0

- 2.2 Governance. The Commission addresses strategic leadership more than administrative detail.
- 2.3 Actions. The Commission will adopt the Port's work plan and budget.
- 2.4 Port Financial Goals. Pursue fewer projects; selecting projects with the greatest return to the Port and to taxpayers.

COMMISSION CODE OF CONDUCT

Part 3.0

3.10 Representation of Port Position. No Commissioner may, without Commission authorization:

Represent the Port with special interest groups, Port tenants or others that seek to do business with the Port.

COMMISSION CODE OF CONDUCT

Part 3.0

A Commissioner may state a position of the *individual Commissioner* (but not that of the Port or of the Commission).

COMMISSION CODE OF CONDUCT

Part 3.0

3.13 Open Meetings. Commissioners shall:

3.13.3 Understand the Washington Open Public Meetings Act applies to communications via telephone, e-mail, instant messaging or other forms of electronic communications.

COMMISSION CODE OF CONDUCT

Part 3.0

Understand that any exchange of communication between any two Commissioners may constitute an official meeting of the Commission in violation of the Act.

COMMISSION CODE OF CONDUCT

Part 3.0

The CEO or his/her designee may communicate information to members of the Commission on an informational basis.

COMMISSION CODE OF CONDUCT

Part 3.0

However, replies and/or exchanges of Commissioner communications regarding Port business must not occur outside of an official public meeting.

COMMISSION CODE OF CONDUCT

Part 3.0

Commissioners will not “reply” or “reply all” to any e-mail received by another member of the Commission.

COMMISSION CODE OF CONDUCT

Part 3.0

3.13.4 A Commissioner shall respect the confidentiality of appropriate issues:

- ✓ personnel
- ✓ real estate
- ✓ proprietary matters
- ✓ attorney-client privileged communications
- ✓ executive sessions, etc.

COMMISSION MEETINGS

Part 6.0

6.10 Remote /Electronic Meetings.

6.10.6 Commission and staff members who are unable to be present may participate by telephonic or internet service.

COMMISSION MEETINGS

Part 6.0

6.15 Executive Sessions. An Executive Session is a Commission meeting that is closed to the public and is attended by the Commission, CEO and others authorized to attend.

The President shall announce the:

- ✓ purpose
- ✓ the specific section of RCW
- ✓ the anticipated time
- ✓ and whether action is expected.

COMMISSION AND PORT ACTION

Part 12.0

12.2 In the case of Commissioners requesting information or assistance without Commission authorization, the CEO and staff must refuse such requests

- ✓ that require a significant amount of staff time or funds, are disruptive to the Port, or which may involve a conflict of interest.

COMMISSION AND PORT ACTION

Part 12.0

12.3 Commissioners individually may communicate directly with Port employees for the purpose of inquiry only.

Commissioners shall, on business matters, deal with staff through the CEO.

COMMISSION AND PORT ACTION

Part 12.0

The Commission as a body and the Commissioners individually do not give direction to persons who report to the CEO.

If an individual Commissioner is dissatisfied with the response from the CEO or staff, the Commissioner may seek resolution through the Commission as a body.

COMMISSION & STAFF ROLES AND RESPONSIBILITIES

Part 13.0

13.1 General Roles. The Commission is the Port's governing authority. All authority not expressly delegated to the CEO is reserved to the Commission.

COMMISSION & STAFF ROLES AND RESPONSIBILITIES **Part 13.0**

The Commission sets Port policies and priorities. The CEO and Port staff execute and administer the Commission's policies.

The CEO is responsible to the Port Commission as a board, rather than to individual Commissioners.

COMMISSION & STAFF ROLES AND RESPONSIBILITIES **Part 13.0**

13.2 Commissioner's Role. The CEO is authorized to make recommendations on policy matters to the Commission and the Commission retains the authority to:

- ✓ Accept
- ✓ reject, or
- ✓ amend the recommendations

COMMISSION & STAFF ROLES AND RESPONSIBILITIES

Part 13.0

All Commissioners with concerns affecting the Port should address those concerns with the full Commission or with the CEO.

COMMISSION & STAFF ROLES AND RESPONSIBILITIES

Part 13.0

No Commissioner shall direct the CEO to initiate any action:

- ✓ without the authorization of a majority of the Commission

COMMISSION & STAFF ROLES AND RESPONSIBILITIES

Part 13.0

- ✓ Commissioner requests for information shall be made to the CEO
- ✓ Commissioners needing staff assistance shall work through the CEO

COMMISSION & STAFF ROLES AND RESPONSIBILITIES

Part 13.0

13.3 CEO's Role.

13.3.4 The CEO shall have an open-door policy which allows individual Commissioners and the public to meet with the CEO on an impromptu, one-on-one basis.

BUDGET AND PROCUREMENT AUTHORITY

Part 14.0

14.2 Financial Policies.

- Fund projects that provide a positive return on investment or which provide important non-economic benefits;
- Eliminate/ transfer to private sector, holdings which provide minimal economic or community benefit;
- Reduce costs and enhance revenues when feasible while maintaining acceptable service levels;
- Ensure the Port's portfolio includes diversity of revenue streams to offset risk adverse projects;

BUDGET AND PROCUREMENT AUTHORITY

Part 14.0

- Accurately forecast funding sources;
- Creating successful strategies for capital acquisitions;
- Leveraging funds by seeking grants and matching funds from the public and private sectors;
- Accurately and honestly identifying potential financial issues and providing feasible potential solutions.

Port of Kennewick Community Ambassador Policy

Tim Arntzen, CEO

March 24, 2026

PURPOSE

- ✓ To recognize those who have provided services in the past and will provide future volunteer services to the Port
- ✓ In recognition of the benefits to the Port from a continuing relationship with active, distinguished persons who assist the Port as a volunteer with community, trade and/or economic development activities

ELIGIBILITY AND APPOINTMENT

- ✓ Port resident
- ✓ Former Port Commissioner 10 or more years
- ✓ Staff member 10 or more years
- ✓ Recommendation from 3 Port electors
- ✓ Approved by Port Commission

AMBASSADOR SERVICE TO THE PORT

Activities that pertain to service on behalf of the Port.

Limitations:

- ✓ Cannot enter into commitments.
- ✓ Cannot make public comments which are not expressive of the viewpoint of the Commission.

REIMBURSED EXPENSES AND STIPEND FOR AMBASSADOR SERVICE

- ✓ Reimbursement for expenses
- ✓ General stipend
- ✓ Stipend for health insurance premiums